

February 2010



Xerox[®] 8264E[™] Color Wide Format Printer User Maintenance and Cleaning Guide



©2010 Xerox Corporation. All rights reserved. Xerox and the sphere of connectivity design and all product names mentioned in this publication are trademarks of Xerox Corporation in the United States and/or other countries.

Microsoft Windows® is a trademark of Microsoft Corporation in the United States and/or other countries. Adobe®, PostScript®, PostScript®3™, and PostScript Logo® are trademarks of Adobe Systems Incorporated in the US and/or other countries. AutoCAD® is a registered trademark of Autodesk, Inc.

Copyright protection claimed includes all forms and matters of copyrightable material and information now allowed by statutory judicial law or hereinafter granted, including without limitation, material generated from the software programs displayed on the screen such as icons, screen displays, or looks.

Printed in the United States of America.

Changes are periodically made to this document. Changes, technical inaccuracies, and typographic errors will be corrected in subsequent editions.

Document Version: 1.0 (February 2010).

Table of Contents

Introduction	2
Cleaning Supplies	2
Cleaning	3
Cleaning the Head.....	4
Cleaning the Cleaning Wiper	5
Cleaning Around the Cap	8
Cleaning Around the Print Head.....	9
Replacing the Flushing-box Sponges.....	14

Introduction

The purpose of this document is to provide the user or key operator with details of the required User Maintenance and Cleaning procedures. These cleaning procedures must be performed to ensure maximum uptime and superior image quality for your Xerox 8264E printer. Failure to perform these procedures at the recommended intervals may cause damage to the machine and void your Service Agreement.

This is a supplementary document that should be used in conjunction with the Xerox 8264E Color Wide Format Printer User Guide located on the documentation CD delivered with your printer. Please refer to *Section 6: Maintenance* of the User Guide, for complete step by step instructions for performing these procedures and general maintenance of the printer. A video of these procedures is available at www.xerox.com/support.

Cleaning Supplies

The supplies necessary for cleaning the Xerox 8264E are available through Xerox Supplies:

- United States: 1-800-822-2200
- Canada: (English) 1-800-668-0199
- Canada: (French) 1-800-668-0133
- Europe: 44 (0) 1442 88 60 19
- For all other countries please go to www.xerox.com, select your local website and look for the required contact information under the supplies section.

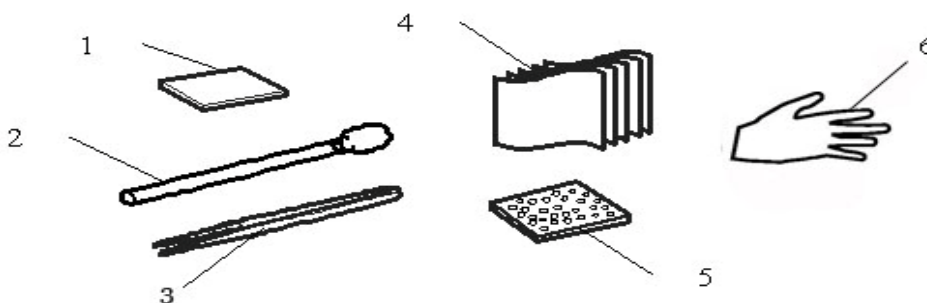

No	Name	Units / Carton
1	Cleaning wiper	1
2	Cleaning Foam swab	25
3	Plastic tweezers	1
4	Lint free cloth	30

5	Flushing Box Sponge	1 box of 5
6	Latex Gloves	10

Cleaning

Weekly and monthly cleaning are necessary to keep the printer in good condition. This section describes how to clean each part of the printer.

Twice per Week:

- Cleaning the Head
- Cleaning the Cleaning Wiper

Weekly:

- Cleaning around the Cap
- Cleaning around the Print Head

Monthly:

- Replacing the Flushing-box Sponges

CAUTION:

- **Never** disconnect the printer's power cable(s) from the building's electrical outlet without **first** pressing the [Power] key to turn the printer OFF. Doing so can cause the printer to misread how much ink is still in the cartridges. It may indicate a cartridge is empty when it is not. If this happens, there is no option but to replace the cartridge. This can lead to dramatic waste of ink.

WARNINGS:

- Do not insert or drop metal or flammable objects into the printer through openings such as a fresh air inlet. Doing so could lead to an electric shock or fire.
- If foreign substances or liquids such as water enter the printer, do not use the printer. It could lead to an electric shock or fire. Immediately press the [Power] key to turn the printer OFF, disconnect the power cables from the electric outlet, and contact your local Xerox dealer.

CAUTIONS:

- When cleaning the printer, be sure to first press the [Power] key to turn the printer OFF and then disconnect the power cable from the electrical outlet.
- Do not use volatile solvents such as thinner, benzene, or alcohol. These solvents could cause damage to the paint.
- Be careful that no moisture enters the printer. There is a possibility that the electric circuit inside the printer could cause a short circuit.

WARNING:

- Do not, under any circumstances, open covers attached using screws. This may cause an electric shock or a malfunction.

Cleaning the Head

If printed data is blurred or partly missing, clean the print head surface and nozzle. (This is referred to as head cleaning.)

Follow the procedure below to perform head cleaning.

Notes:

- If the printer is not to be used for a week or more, perform head cleaning once a week. If you do not perform head cleaning, the print head will become clogged. Cleaning the print head will preserve print quality.
- Remove the media when cleaning.
- Cleaning with the media loaded may lead to contact between the print head and media.

1. Confirm that "Ready to Print" is displayed in the control panel.
2. Check that the media loading lever is lowered.
3. Press the [>] key to select the cleaning mode.

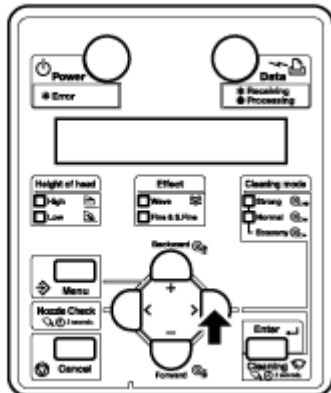

4. Press and hold the [Cleaning] key for at least two seconds.

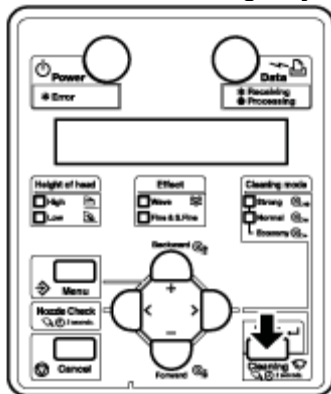

- Head cleaning begins.
- "Cleaning **%" displays in the control panel
- After head cleaning is complete, "Ready to Print" displays in the control panel.

Notes:

- If blurring or incomplete printing continues after one head cleaning, repeat the process, using the Strong cleaning setting.
- If blurring or incomplete printing do not disappear after several head cleanings, refer to [Troubleshooting](#) in the User Guide, and take appropriate measures.

Cleaning the Cleaning Wiper

This section describes when and how to clean the cleaning wiper.

1. Cleaning frequency

The cleaning wiper should be cleaned once or twice a week or when blurs or in complete printing appear on printed media after head cleaning.

2. Cleaning method

Follow the procedure below to clean the cleaning wiper.

Note:

- Use a new foam swab or lint free cloth to clean the cleaning wiper. Use Eco-cleaning solution or Isopropyl Alcohol with the swab or cloth.

For details on the foam swab and the lint free cloth, refer to [Options/Supply List](#) in the User Guide.

1. With the printer turned ON, make sure of the following.
 - Printing or other operations are not in progress.
 - "Ready to Print" displays in the control panel.
2. Display the CR Maintenance menu in the control panel.
 - a. Press the [Menu] key. "Menu 1: Setup>" displays in the control panel.

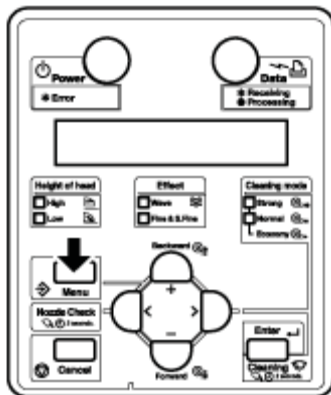

- b. Press the [>] key. "Set1: MediaType" displays in the control panel.

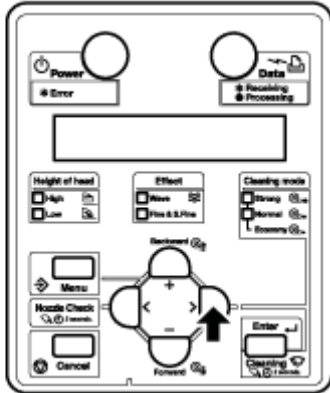

c. Press the [+] key or [-] key to select "Set20: CR Maintenance."

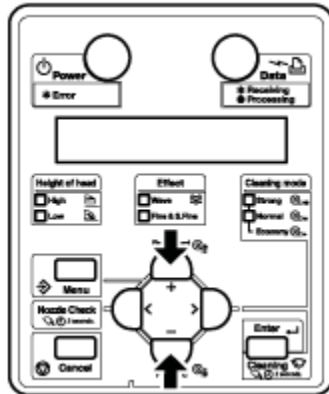

d. Press the [Enter] key. "CR Mainte.: Start" displays in the control panel.
[CR Maintenance Menu](#)

3. Press the [Enter] key.

- Maintenance starts.
- The print head moves to the left.
- The cleaning wiper moves forward.
- "CR Maintenance: End" displays in the control panel.

CAUTION:

- Use gloves included in the cleaning kit to prevent ink and cleaning solvent from getting on hands. Do not touch the wiper without gloves. Oil from your hands may prevent the wiper from cleaning the head properly.

4. Open the maintenance cover on the right front of the printer.

CAUTION:

When cleaning the cleaning wiper:

- Do not touch the cleaning wiper or head cap unit with your fingers. Head cleaning may not be performed correctly because of oil from your fingers.

5. Use the foam swab or the lint free cloth to remove the ink and dust on the cleaning wiper. Use Eco-cleaning solution or Isopropyl Alcohol with the swab or cloth.

a. Cleaning the front side of the wiper:

Remove the ink and dust by moving the foam swab or lint free cloth to the right and left.

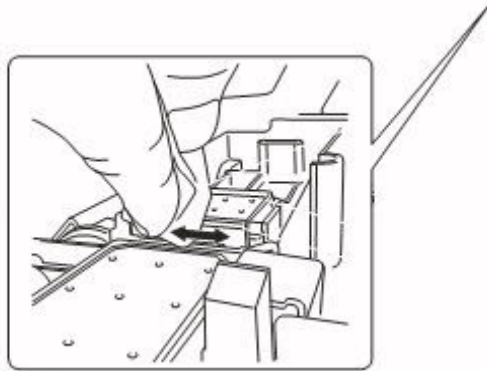
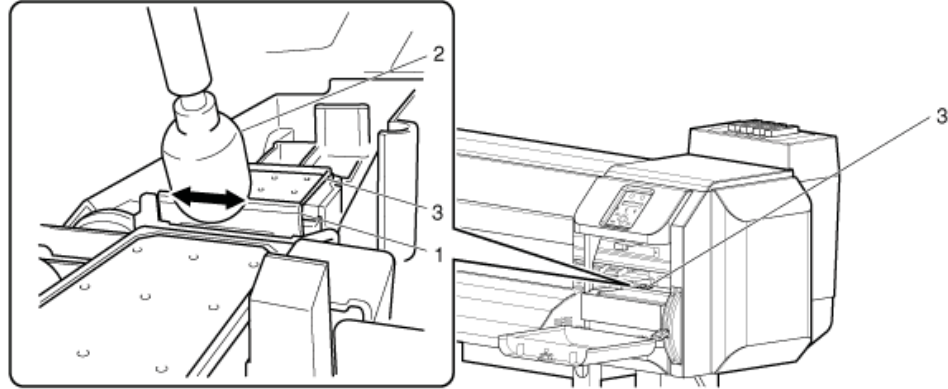

No.	Name
1	Cleaning wiper
2	Foam swab or lint free cloth
3	Head cap unit

- a. Cleaning the back side of the wiper:
Remove the ink and dust by moving the foam swab or the lint free cloth from bottom to top.

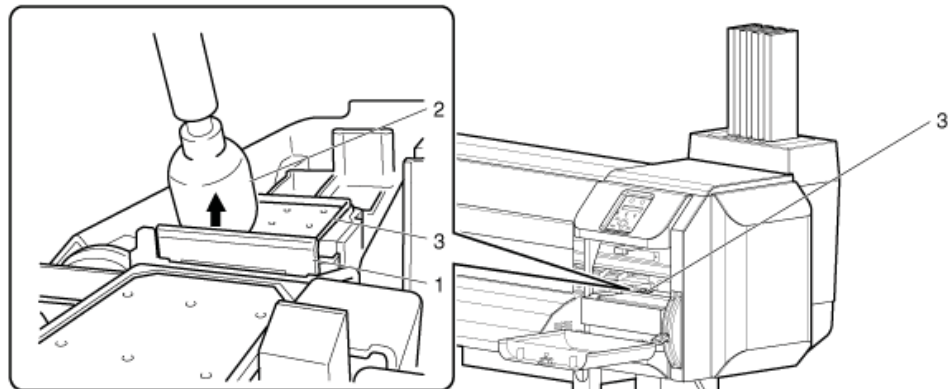

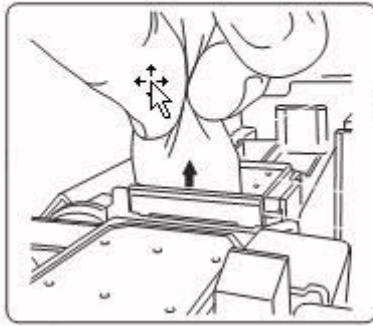

6. Close the maintenance cover on the right front of the printer firmly until it is locked.

7. Press the [Enter] key.

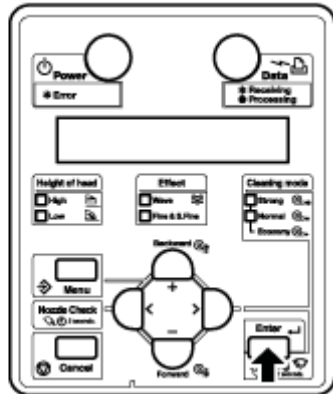

- a. The print head returns to its original position.
- b. The cleaning wiper returns to its original position.
- c. "CR Mainte.: Start" displays in the control panel.

8. Press the [Cancel] key several times. "Ready to Print" displays in the control panel.

Cleaning of the cleaning wiper is complete.

Cleaning Around the Cap

This section describes how to clean around the cap.

CAUTION:

- Use the gloves included in the cleaning kit to prevent ink and cleaning solvent from getting on your hands. Do not touch the rubber cap without gloves. Oil from your hands may prevent the cap from sealing properly.

1. Using either a foam swab or a lint free cloth soaked in Eco-cleaning solution or Isopropyl Alcohol, wipe around the edges of the rubber cap. This ensures a good seal is maintained during the head cleaning process.

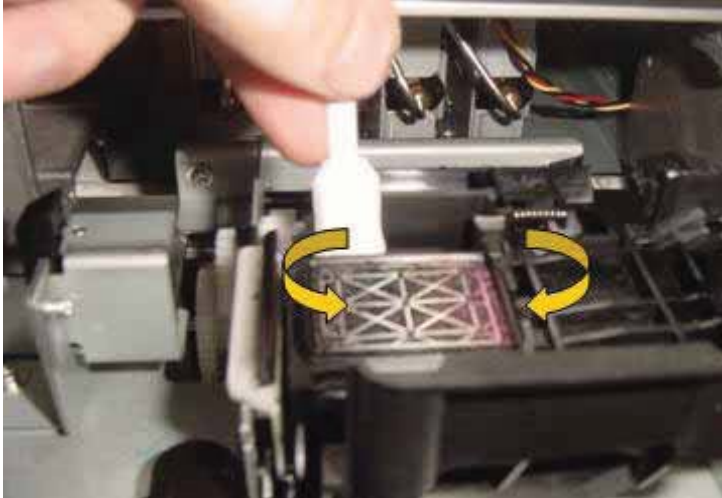

2. If cap should become clogged with dried ink, flood the top of the cap using an eye dropper filled with Eco-cleaning solvent. Allow time for solvent to dissolve dried ink until solvent can be seen flowing into the waste bottle.

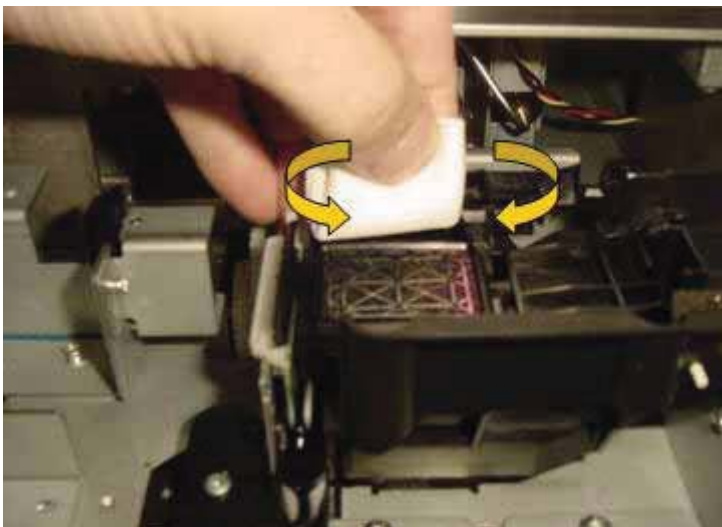

3. Close the maintenance cover on the right front of the printer firmly until it is locked.

4. Press the [Enter] key.
- The print head returns to its original position.
 - The cleaning wiper returns to its original position.
 - "CR Mainte.: Start" displays in the control panel.

Cleaning Around the Print Head

This section describes how to clean around the print head.

1. Cleaning frequency

The area around the print head should be cleaned once per week, or whenever foreign objects, such as dust or ink, cause omitted dots, or whenever ink drops are attached around the print head.

2. Cleaning method

Follow the procedure below to clean around the print head.

CAUTION:

- Use the gloves included in the cleaning kit to prevent ink and cleaning solvent from getting on your hands. Do not touch the rubber cap without gloves. Oil from your hands may prevent the cap from sealing properly.

Follow the procedure below to clean around the print head.

Notes:

- Before starting to clean around the print head, read and understand this procedure, then clean promptly and accurately.
- When cleaning around the print head, the print head cap must be removed and cleaning must be complete before the head dries. The recommended time for cleaning is about fifteen minutes.
- If cleaning exceeds fifteen minutes, discontinue it by following Steps 7 and 8. Perform a head cleaning, and then start cleaning around the print head again.

Cleaning the Head

- Use the foam swab to clean around the print head.

For information on the foam swab, refer to [Options/Supply List](#).

1. If the printer is turned ON, make sure of the following.

- Printing or other operations are not in progress.
- "Ready to Print" is displayed in the control panel.

2. Display the CR Maintenance menu in the control panel.

- a. Press the [Menu] key. "Menu 1: Setup>" displays in the control panel.

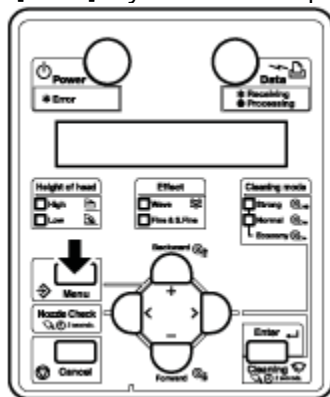

- b. Press the [>] key. "Set1: MediaType" displays in the control panel.

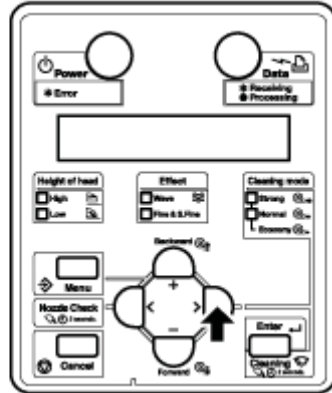

c. Press the [+] key or [-] key to select "Set20: CR Maintenance".

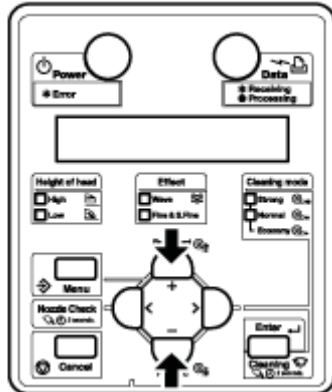

d. Press the [Enter] key. "CR Mainte.: Start" displays in the control panel.

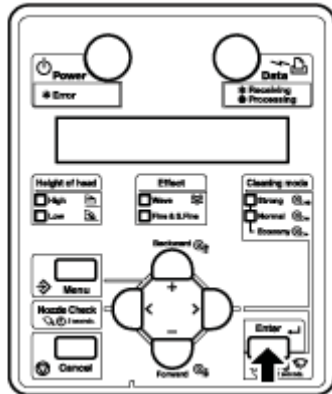

CR Maintenance Menu

3. Press the [Enter] key.

- Maintenance starts.
- The print head moves to the left.
- "CR Maintenance: End" displays in the control panel.

4. Open the left maintenance cover.

5. Using a light such as a penlight, confirm that there are no foreign objects, such as dust or ink

attached to the following parts:

- Around the print head

- Head guide area
- Nozzle

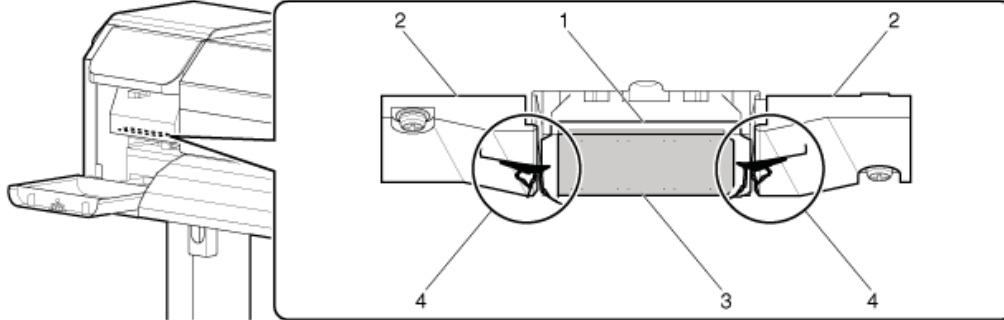

No.	Name
1	Around the print head
2	Head guide area
3	Nozzle
4	Dust, ink mass

5. Using a foam swab or lint free cloth, clean the following areas under the carriage.
- Stainless steel ring around the head
 - Space between the print head and the guide ramps
 - Bottom sides of the guide ramps
 - Any other areas under the print head carriage that appears to have ink or dirt build-up.

CAUTION:

When cleaning around the print head:

- Do not touch the nozzle of the print head. Doing so may damage the print head.
- Do not touch the head of the foam swab with your fingers. Oil on your fingers may attach to the foam swab, causing damage to the print head.
- Do not immerse the head of the foam swab in water. Doing so may damage the print head.
- Do not re-use the foam swab. Dust attached to the stick may damage the print head.

6. Using Eco-cleaning solvent with a foam swab or lint free cloth, clean the following areas under the carriage:
- Stainless steel ring around the head
 - Space between the print head and the guide ramps
 - Bottom sides of the guide ramps
 - Any other areas under the print head carriage that appears to have ink or dirt build-up

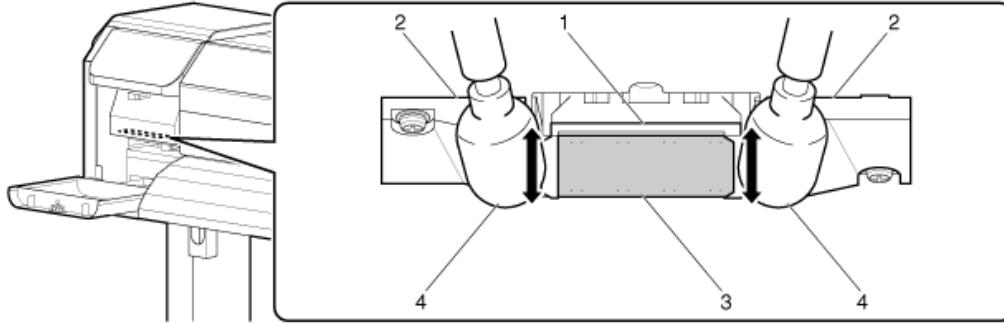

No.	Name
1	Around the print head
2	Head guide area
3	Nozzle
4	Dust, ink mass

7. Pay special attention to the areas on either side of the print head. The small gap between the print head and the guide ramps can build up large amounts of ink and dust.

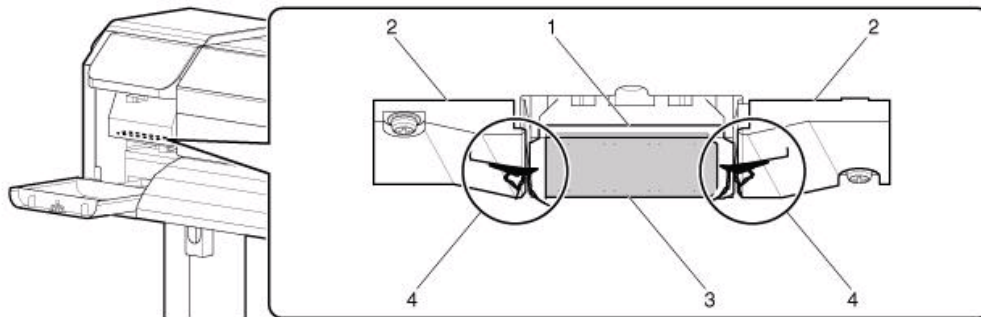

8. Close the maintenance cover on the left front of the printer firmly until it is locked.

9. Press the [Enter] key.

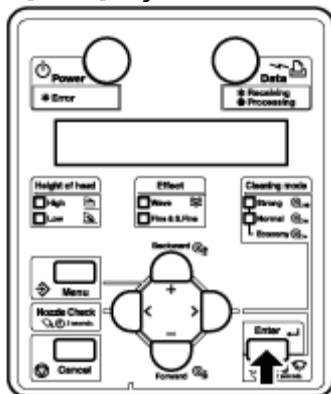

- The print head returns to its original position.
- The print cleaning wiper returns to its original position.
- "CR Mainte.: Start" displays in the control panel.

10. Press the [Cancel] key several times. "Ready to Print" displays in the control panel.

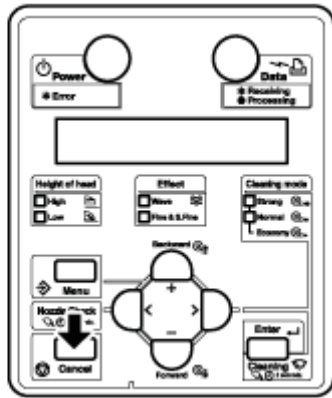

Cleaning around the print head is complete.

Replacing the Flushing-box Sponges

This section explains how to replace the flushing-box sponges.

1. Replacement frequency

Replace the flushing-box sponges in the following situations.

- a. When the flushing-box sponge becomes deformed
- b. When smears of ink appear on the media
- c.. One month after the last replacement

2. Type

Note:

For types and details of the flushing-box sponge, refer to [Options/Supply List](#).

3. Replacing steps

Follow the steps below to replace the flushing-box sponges.

1. If the printer is turned ON, make sure of the following.
 - Printing or other operations are not in progress.
 - "Ready to Print" is displayed in the control panel.
2. Open the front cover.
3. Remove the flushing-box sponge from each flushing-box using a pair of tweezers.

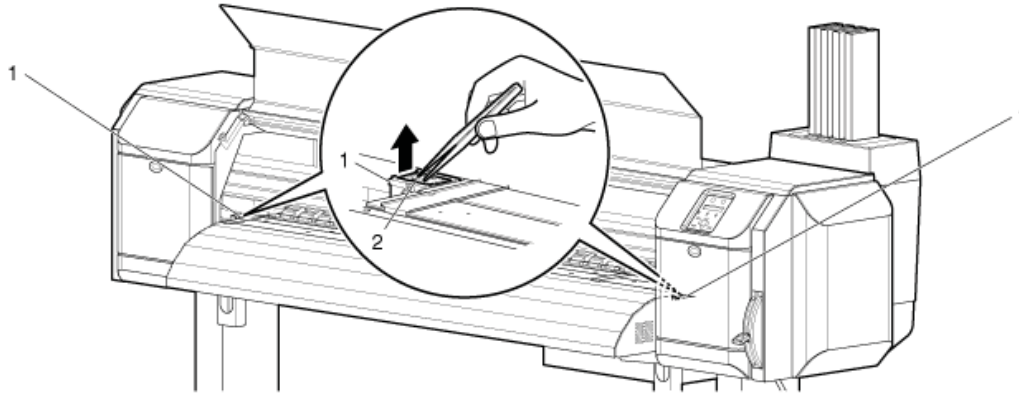

No.	Name
1	Flushing-boxes (two)
2	Flushing-box sponges

Note:

Replace the sponge on the left hand side of the printer as needed. If the left side flushing-box is not used often and the sponge appears clean, it does not need to be changed.

CAUTION:

- Do not drop waste fluid when replacing the flushing-box sponges. If waste fluid comes into contact with the grid roller, the surface of the grid roller will be damaged and the media feed function may be affected.

4. Install a new flushing-box sponge into each flushing-box.

5. Close the front cover to complete the procedure.