

Xerox Wide Format Solutions

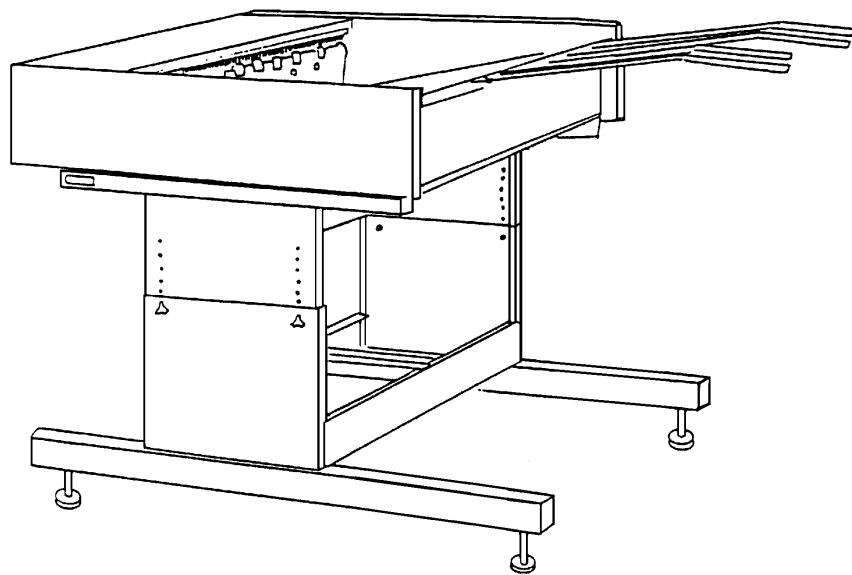

8855/721P Stackel ***Operator Manual***



THE DOCUMENT COMPANY

XEROX

701P39432

Prepared by:
Global Knowledge and Languages
Services
780 Salt Road
Webster, New York 14580

Copyright© 2003 by Xerox Corporation.
Allrights reserved. XEROX and all
product names and number names are
trademarks of XEROX
CORPORATION. Other company
trademarks are also acknowledged.
Printed in U.S.A.

701P39412

5/2003

Table of Contents

It's Illegal	2
FCC Compliance	2
Introduction to your Stacker	3
Safety Notes	4
Identifying the Parts on the Stacker	6
Location of the Stacker Serial Number	7
Stacker Operation	7
Stacker Jam Clearance	7
Stacker Relocation	8
Technical Data	9

It's Illegal

In the USA

It is against U.S. law to copy copyrighted material without permission of the copyright owner unless the copying falls within the "Fair Use" library reproduction rights of the copyright law.

Further information on these U.S. provisions may be obtained from the Copyright Office, Library of Congress, Washington, D.C. 20550, or telephone the Copyright Office at (202) 707-9100 and ask for circular 21. Copying other items may be prohibited. If you have any questions seek legal advice.

FCC Compliance

In the USA

Class A

This equipment has been tested and found to comply with the limits for a Class A digital device, pursuant to Part 15 of the FCC rules. These limits are designed to provide reasonable protection against harmful interference when the equipment is operated in a commercial environment. This equipment generates, uses, and can radiate radio frequency energy and, if not installed and used in accordance with the instruction manual, may cause harmful interference to radio communication. Operation of this equipment in a residential area is likely to cause harmful interference, in which case the user will be required to correct the interference at their own expense.

If necessary, the user should consult the dealer or an experienced radio/television technician for additional suggestions. The user may find the following booklet prepared by the Federal Communications Commission helpful:

How to Identify and resolve Radio-TV Interference Problems
Stock Number: 004-000-00345-4.

Introduction to Your Stacker

Congratulations on acquiring your new Stacker.

This User Guide provides information that is needed to operate the Stacker.

The information below is needed when you call your Xerox support experts.

1. Customer Account Number: _____

2. Stacker Serial Number: _____

To Locate the Stacker Serial Number, refer to page 7.

3. Printer Serial Number: _____

To Locate the Printer Serial Number, refer to Printer User Guide.

Note: All service calls should be reported under the printer serial number.

FOR SERVICE: 1-800-822-2979

A Customer Service Support Representative will assist you in keeping your stacker operational and, if required, will arrange for a Customer Service Engineer to visit your stacker and restore its performance.

PURCHASE OF OTHER EQUIPMENT:

Call a local Marketing Representative. They will assist you in determining and ordering other office equipment that will further increase your productivity.

Local Marketing Representative phone number:

Safety Notes

Your stacker has been designed and tested to meet strict safety requirements. These include safety agency examination and approval, and compliance to established environmental standards. Please read the following instructions carefully before operating the Stacker.

NOTE: Refer to Instructions as needed to ensure the continued safe operation of your stacker.

FOLLOW all warnings and instructions marked on or supplied with the product.

UNPLUG the stacker from the wall outlet before cleaning. Always use materials supplied or approved by Xerox. Use of other materials may result in poor performance and could create a hazardous situation.

DO NOT use aerosol cleaners

NEVER use supplies or cleaning materials for purposes other than what they were intended. Keep all supplies and materials out of reach of children.

DO NOT use the stacker near water, wet locations, or outdoors.

WARNING

This copier must be grounded.

THIS PRODUCT is equipped with a 3-wire grounding-type plug (i.e., a plug having a third grounding pin) and an additional safety device. This plug will only fit into a grounding-type power outlet. This is a safety feature. To avoid risk of electric shock, contact your electrician to replace the receptacle if you are unable to insert the plug into the outlet. Never use a ground adapter plug to connect the copier to a power source receptacle that lacks a ground connection terminal.

THIS STACKER should be operated from the type of power source indicated on the marking label. If you are not sure of the type of power available, consult your local power company.

IF AN EXTENSION CORD is used with this stacker, ensure that the total of the ampere ratings of the products plugged into the extension cord does not exceed the extension cord ampere rating. Also, make sure that the total amperage of all products plugged into the wall outlet does not exceed the outlet protection.

DO NOT install the stacker in direct sunlight, a high humidity or dusty environment.

DO NOT install the stacker where the floor or base is unstable. The stacker may fall, causing personal injury and/or serious damage to the stacker.

NEVER spill liquid of any kind on the stacker.

DO NOT allow anything to rest on the power cord. Do not locate this stacker where people will step on the cord.

NEVER remove any covers or guards that require a tool for removal. There are no operator-serviceable areas within these covers.

THE POWER SUPPLY CORD is the disconnect device for this stacker. Ensure that installation is near the outlet and is easily accessible.

NEVER attempt any function that is not specified in this User Guide or directed by an authorized Xerox representative.

Safety Notes (continued)

UNPLUG this stacker from the wall outlet and refer servicing to qualified service personnel under the following conditions:

- When the power cord is damaged or frayed.
- If liquid has been spilled into the product.
- If the stacker has been exposed to rain or water.
- If the stacker is producing unusual noises or odors.
- If the stacker has fallen or the cabinet has been damaged.
- The safety feature has been activated for a second time.
- The stacker still does not work, or continues to malfunction, after following the procedures in this User Guide.

If you need additional safety information concerning the copier or materials supplied by Xerox, you may call the following toll-free number: **1-800-828-6571**.

Identifying the Parts on the Stacker

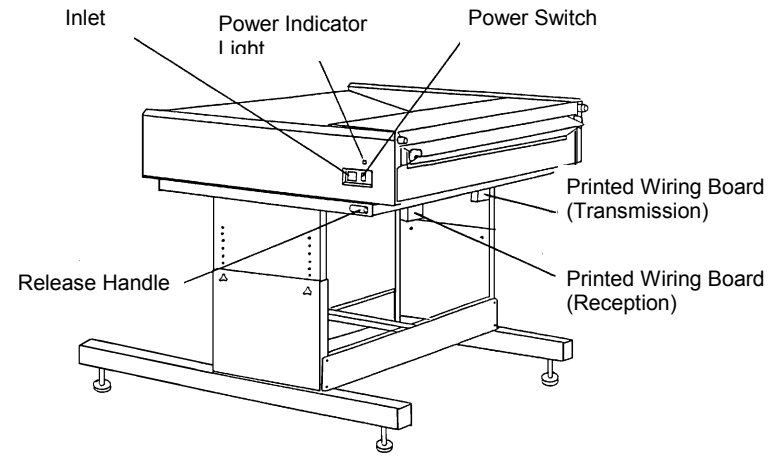
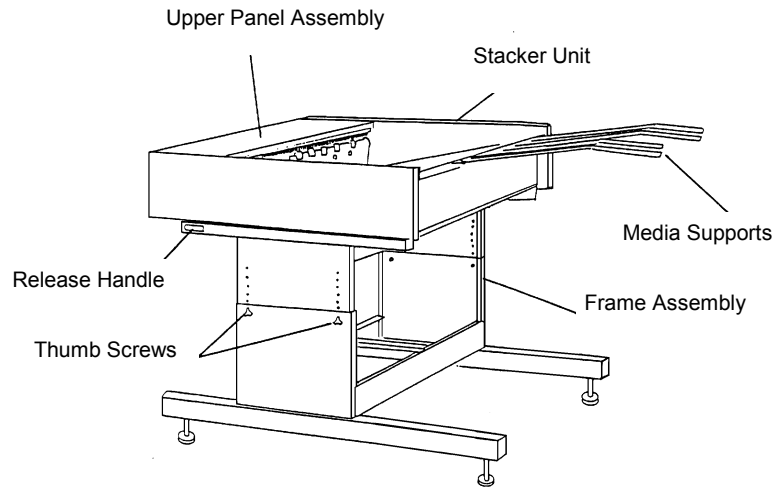

Location of the Stacker Serial Number

In order to locate the serial number of your stacker, you must first push down the release lever and slide the stacker away from the printer.

The serial number plate is located on the left of the front cover facing the printer.

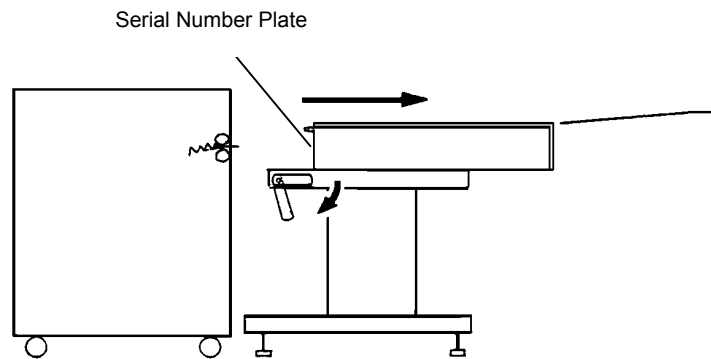

Figure 1. Sliding the Stacker away from the Printer.

Stacker Operation

If you are running paper larger than a 24" (610mm) raise the paper supports.

In order to turn on your stacker, press the power switch to the on position. When the stacker is on the green Power Indicator Light is visible.

NOTE: There is no start up sequence between the stacker and the printer (either the stacker or the printer may be turned on first). If your stacker does not run, turn off both the printer and the stacker. Turn on the stacker then turn on the printer. If the stacker still does not function, verify power source and then call for service.

Stacker Jam Clearance

The paper fed from the printer will be either cut or uncut.



Caution

To ensure the safety of the user, be aware during jam clearance that the surface will be hot.

Cut

In order to clear a jam in the stacker, lift the Upper Panel Assembly and clear any paper (Figure 2). If the jam still exists, push down on the release lever and move the stacker away from the printer (Figure 1). Clear any visible paper from the paper path.

Uncut

Cut the paper in the printer (refer to the printer user guide) and follow the above procedure.

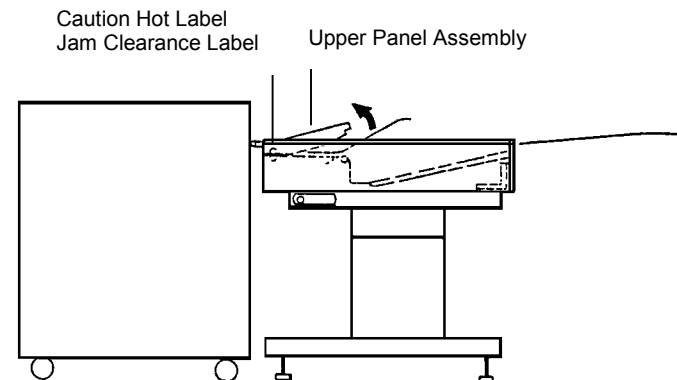

Figure 2. Lifting the Upper Panel Assembly.

NOTE; The Transmission PWB and the Reception PWB are infrared connections (See Identifying the Parts on the Stacker). To ensure proper operation of the stacker, these connections must be debris free.

Stacker Relocation

The stacker cannot be moved except by a DRC rigger.

To ensure that the stacker operates reliably after moving it to a new location, consider the following guidelines:

- The new location must provide minimum clearances around the stacker. These clearances are shown in the diagram on the right.
- The flooring in the new location must be adequate to support the weight of the stacker and be reasonably level.
- The new location must be well ventilated and maintain an even temperature. Extreme temperature or humidity changes can affect the stacker.
- Power source receptacles must be properly grounded.

In addition to the above requirements, the surface must be at least 157" (400cm) x 153.5" (390cm) and be capable of supporting at least 108lb (49kg) stacker and the 880lb (400kg) printer attached.

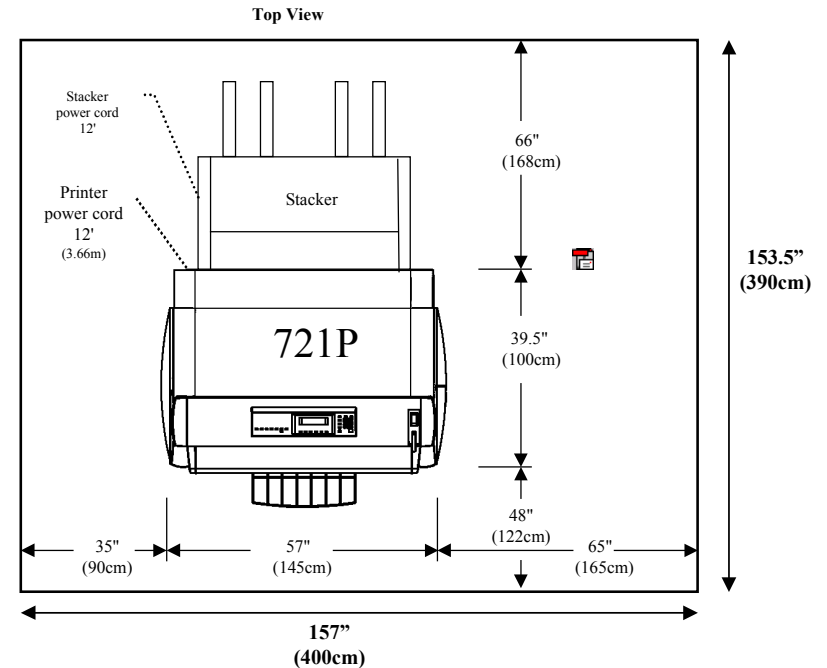

Technical Data

Dimensions: Width: 34" (864mm)
57.5" (1461mm) w/paper supports extended.
Depth: 41" (1041mm)
Height: 28.5" (724mm)

Weight: 108 lbs. (49kg)

Paper Size: 36 x 48" (914mm x 1219mm) Max.

Stacker Capacity: 200 sheets of plain paper with minimal scatter
500 plain paper sheets Max.

Electrical Data:

Current service: 3 Amps or more
Power Supply: 110V - 240V
Frequency: 50/60Hz

Power Consumption: 60W

Temperature: 50°F - 90°F (10°C - 32°C)

Humidity: 20 - 85%

Noise Level: 57dB Max. (during operation)