

XES Synergix™

8825/8830

Printer Operator Manual

701P19710 November 2000



FCC Compliance

In the USA

Class A

This equipment has been tested and found to comply with the limits for a Class A digital device, pursuant to Part 15 of the FCC rules. These limits are designed to provide reasonable protection against harmful interference when the equipment is operated in a commercial environment. This equipment generates, uses, and can radiate radio frequency energy and, if not installed and used in accordance with the instruction manual, may cause harmful interference to radio communication.

Operation of this equipment in a residential area is likely to cause harmful interference, in which case the user will be required to correct the interference at their own expense.

If necessary, the user should consult the dealer or an experienced radio/television technician for additional suggestions. The user may find the following booklet prepared by the Federal Communications Commission helpful:

How to Identify and resolve Radio-TV Interference Problems

Stock Number: 004-000-00345-4.

EME Compliance in Canada

This digital apparatus does not exceed the Class A limits for radio noise emissions from digital apparatus set out in the radio interference regulations of the Canadian Department of Communications.

Trademark Acknowledgments

XEROX®, XES™, Synergix™, The Document Company, and the identifying product names and numbers herein are trademarks of XEROX CORPORATION.

Windows NT®, Windows® 95, Windows® 98, and Windows® 2000 are registered trademarks of Microsoft Corporation.

Internet Explorer is a copyright protected program of Microsoft Corporation.

Microsoft® Word is a copyright protected program of Microsoft Corporation.

PowerPoint is a trademark of Microsoft Corporation.

Netscape is a registered trademark of Netscape Communications Corporation.

CorelDRAW is a registered trademark of Corel Corporation.

PostScript is a trademark of Adobe Systems Incorporated.

HP-GL/2 is a trademark of Hewlett-Packard Company.

AutoCAD is a registered trademark of Autodesk, Inc.

ADI is a registered trademark of Autodesk, Inc.

HDI is an acronym for Heidi® Device Interface. Heidi is a registered trademark of Autodesk, Inc.

Introduction

Congratulations on acquiring your new XES Synergix 8825/8830 Printer. We look forward to supporting you and helping you to increase your printing productivity. The integrated features, the ease of operation, and the reliability of your new equipment will allow you to concentrate on your business and leave the printing to your Printer or Digital Document System.

This operator manual provides the information that you need to become familiar with the features, documentation components, operations, and specifications of the equipment that you purchased.

**Be sure to check the XES Web Site (XES.com)
for the latest documentation and firmware
upgrades.**

Our support group is available to you for further assistance. The following information will be needed when you call:

Customer Account Name: _____

Customer Account Number: _____

Machine Type: XES Synergix 8825/8830 Printer

Printer Serial Number: _____

FOR SERVICE ON YOUR PRINTER:

Local Phone Number: _____

A Customer Service Support Representative will assist you in keeping your Printer operating and, if required, will arrange for a Customer Service Engineer to inspect your system and restore its performance.

FOR PURCHASE OF OTHER EQUIPMENT AND SUPPLIES:

Local Phone Number (Equipment) _____

Local Phone Number (Supplies) _____

A Sales Representative will assist you in evaluating your needs for other xerographic equipment that can further increase your productivity.

TABLE OF CONTENTS

SAFETY NOTES.....	2	OFF LINE MENUS	19
PRINTER OVERVIEW	5	General Information	19
Left Side View	5	Printer Menu - Entry	20
Right Side View.....	6	1. Audible Indicators.....	21
Front View.....	7	2. Timers	22
Control Panel	8	3. Printer Adjustments (Density).....	24
POWER ON/OFF	9	4. Finisher Settings.....	25
Switching On and Off	9	5. Diagnostics.....	26
Power Saver, and Rest Mode	10	6. Billing Meters.....	27
MEDIA INFORMATION.....	11	PROBLEM SOLVING.....	28
Loading the Roll Media	11	Status Codes.....	28
Media View Menu.....	15	Media Jams.....	29
MANUAL BYPASS FEED	18	Error Messages	30
		Checking for the Loss of Power	31
		Print Quality.....	32
		CARE	33
		Replacing the Toner Cartridge	33
		Replacing the Waste Bottle.....	36
		Required Tasks	37
		Calling for Service	37
		Ordering Supplies.....	38
		PRODUCT SPECIFICATIONS.....	39

SAFETY NOTES

Your Printer has been designed and tested to meet strict safety requirements. These include safety agency examination and approval and compliance with established environmental standards.

Please read the following instructions carefully before operating the Printer and refer to them as needed to ensure the continued safe operation of your printer.

Follow all warnings and instructions that are marked on or supplied with the product.

Unplug the printer from the wall outlet before cleaning the exterior. Always use materials specifically designated for the Printer. Use of other materials may result in poor performance and could create a hazardous situation.

Do not use aerosol cleaners. Follow the instructions in this operator manual for the correct cleaning methods.

Never use supplies or cleaning materials for purposes other than what they were intended. Keep all supplies and materials out of the reach of children.

Do not use this product near water, wet locations, or outdoors.

This product is equipped with a three-wire, grounding-type plug (i.e., a plug having a grounding pin). This plug will only fit into a grounding-type power outlet. This is a safety feature. To avoid the risk of electric shock, contact your electrician to replace the receptacle if you are unable to insert the plug into the outlet.

Never use a ground adapter plug to connect the printer to a power source that lacks a ground connection terminal.

This product should be operated from the type of power source that is indicated on the label. If you are not sure of the type of power available, consult your local power company.

The power supply cord is the disconnecting device for this equipment. Make sure that the installation is near the socket outlet and is easily accessible.

Do not allow anything to rest on the power cord. Do not locate the printer where someone will step on the cord.

(continued)

SAFETY NOTES (continued)

Slots and openings in the cabinet and in the back and bottom of the printer are provided for ventilation. To ensure reliable operation of the printer and to protect it from overheating, never position the printer so that these openings are near a radiator or heat register. The printer should not be placed in a built-in installation unless adequate ventilation is provided.

Never push objects of any kind into the slots of the printer in order to avoid touching dangerous voltage points or short out parts that could result in a risk of fire or electric shock.

Never spill liquid of any kind on the printer.

Never remove any covers or guards that require a tool for removal. There are no operator serviceable areas within these covers.

Never attempt any maintenance function that is not specified in this operator manual.

Never defeat the interlock switches. Your printer is designed to prevent operator access to unsafe areas. The covers, the guards, and the interlock switches are provided to ensure that the system will not operate when the covers are open.

Unplug the printer from the wall outlet and refer all servicing to qualified service personnel under the following conditions:

When the power cord is damaged or frayed.

If liquid has been spilled into the printer.

If the printer has been exposed to rain or water.

If the printer is producing unusual noises or odors.

If the printer or the cabinet has been damaged.

If you need additional safety information concerning the Printer or supplied materials, you may call the following toll-free number:

1-800-828-6571.

(continued)

SAFETY NOTES (continued)

GROUND FAULT PROTECTION

The printer is equipped with an additional safety feature, a Ground Fault Interrupter (GFI). This safety device will remove all power to the printer if an electrical fault is detected by the GFI.

In the event that power is interrupted to the printer, locate the GFI safety device located on the right side of the printer next to the power cord:

Check that a red indicator appears in the window (A) of the safety device as shown opposite.

If no indicator is present, press and release the black RESET button (B). The red indicator should appear in the window, and power should be restored to the printer.

If the device interrupts power to the printer again, or if power is not restored by performing the above procedure, call Xerox Service to correct the problem.

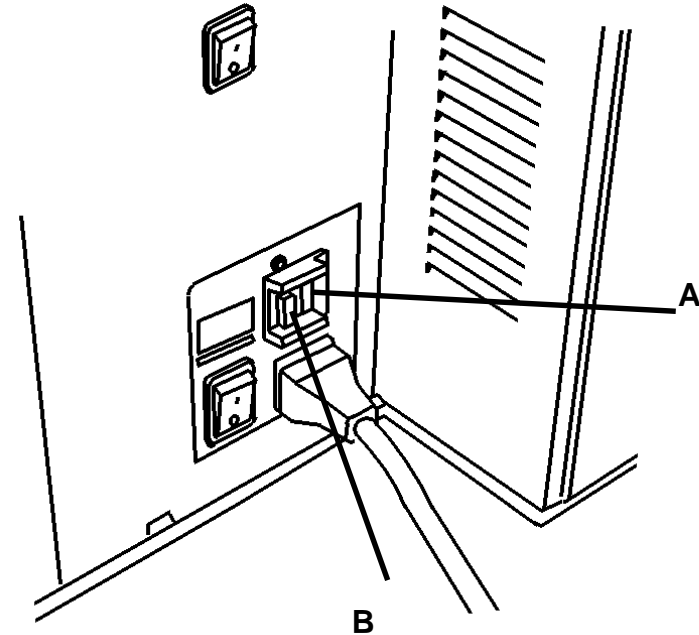

PRINTER OVERVIEW

LEFT SIDE VIEW

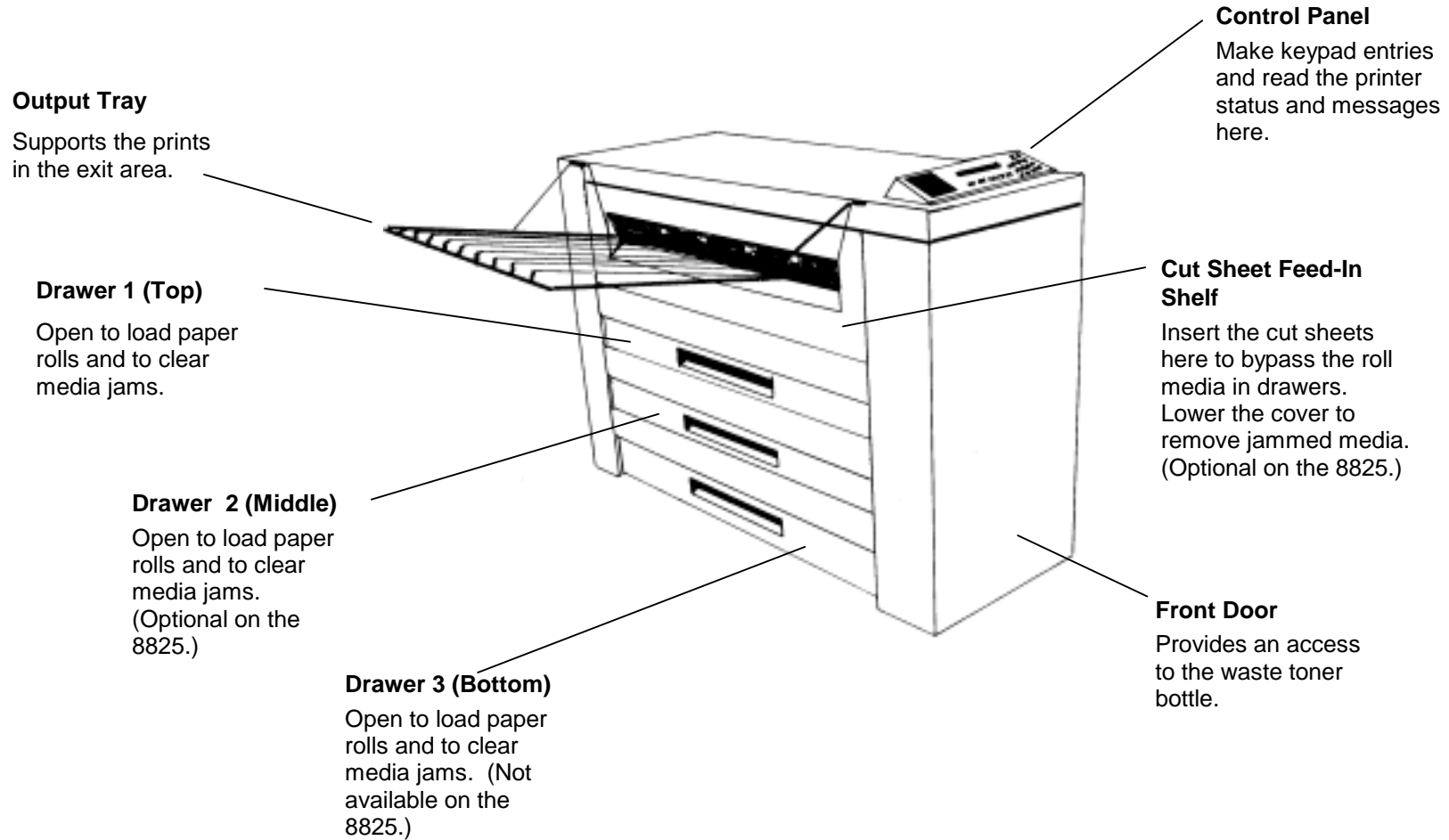

PRINTER OVERVIEW

RIGHT SIDE VIEW

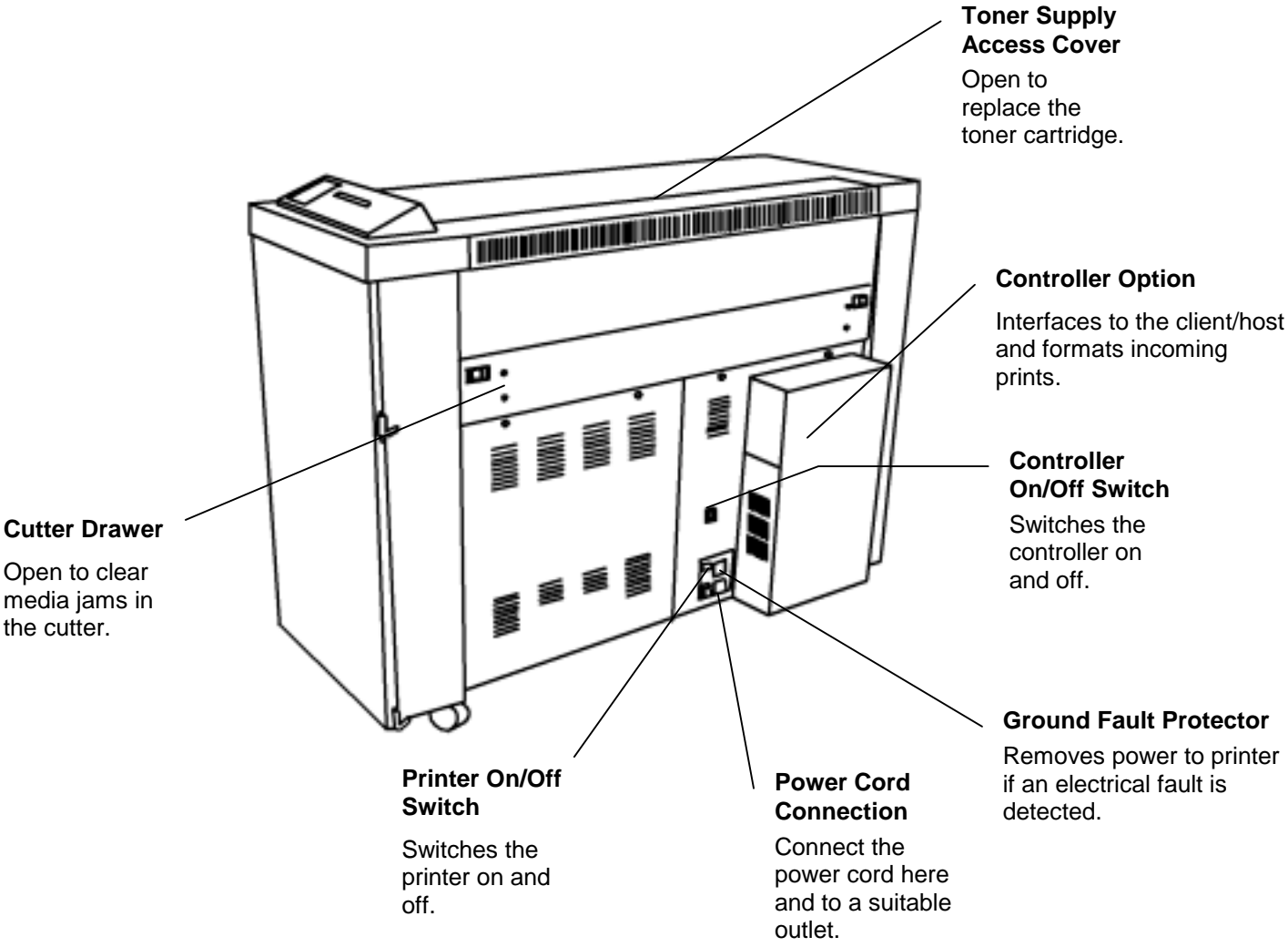

PRINTER OVERVIEW

FRONT VIEW (front door open)

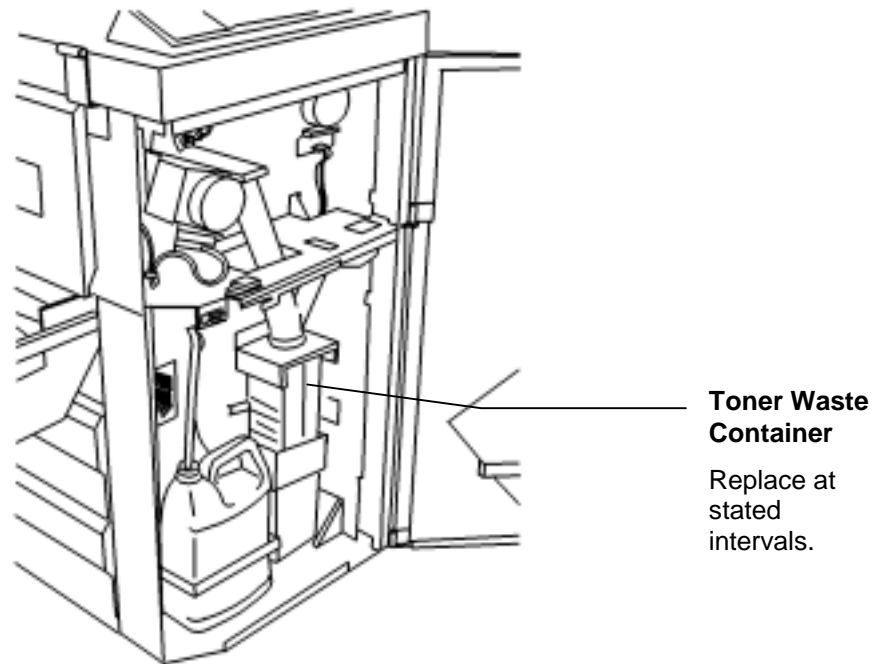

PRINTER OVERVIEW

CONTROL PANEL

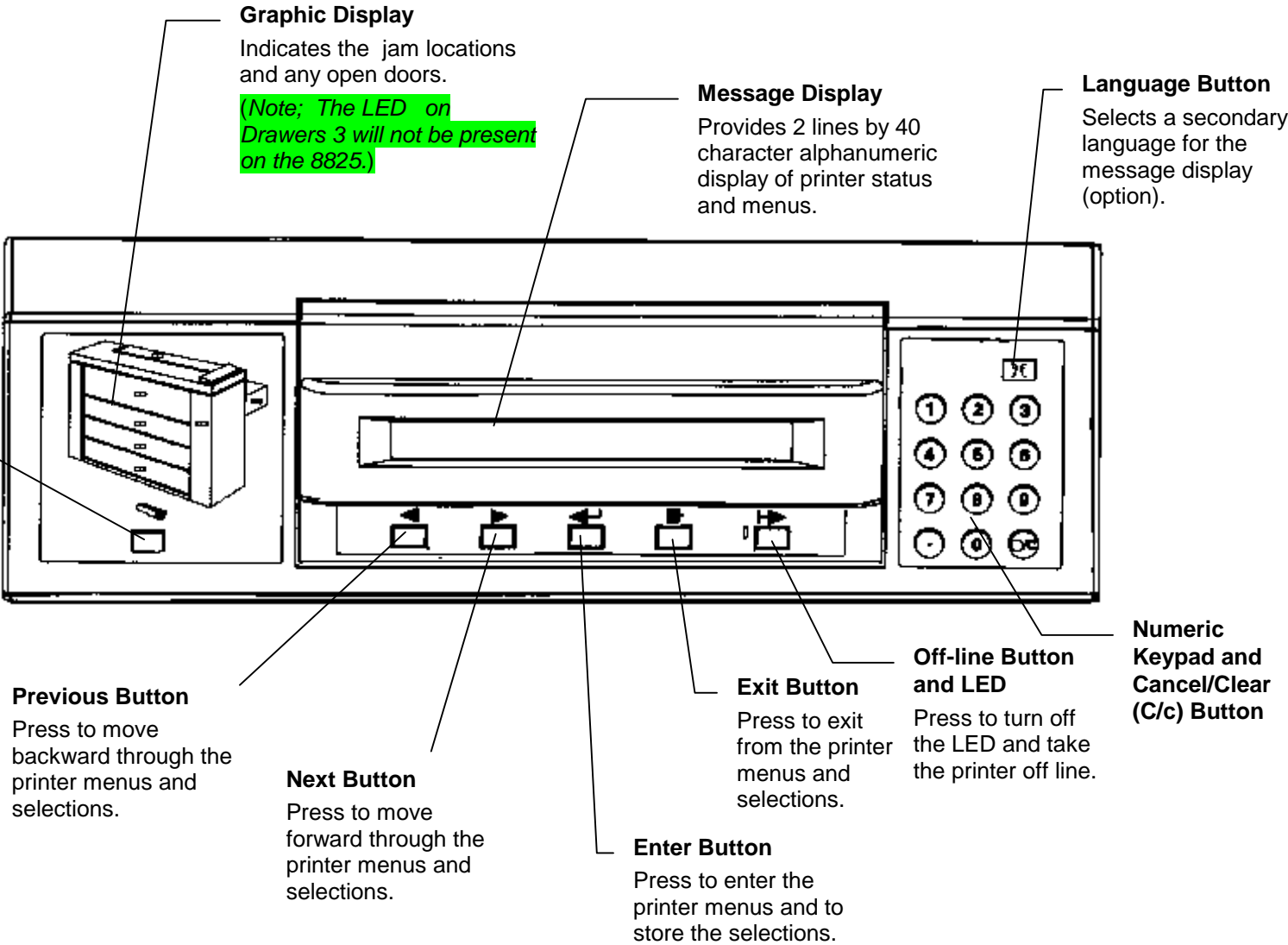

POWER ON/OFF

Switching On and Off

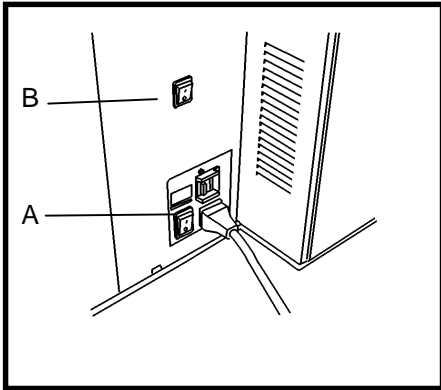

Switching On

Note: Load media in the drawers before switching on the power or after the printer is ready to print

1. Press the Printer power switch (A) to the on (I) position.
2. Press the power switch (B) for the Controller (if installed) to the on (I) position.

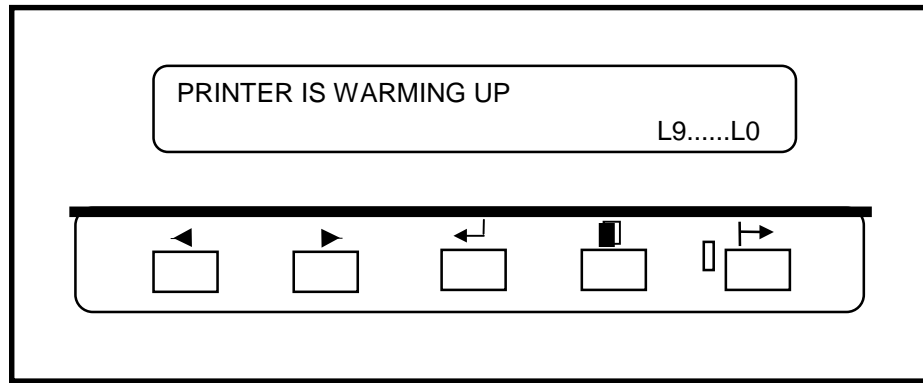

- The printer will count down briefly from L9 to L0 while the fuser is warming up to the operating temperature.
- After the count down is complete, the printer will be On Line and ready to print.

Switching Off

1. Press the Controller power switch (B) to the Off (O) position.
2. Press the printer power switch (A) to the off (O) position

POWER ON/OFF

Power Saver, Rest Modes

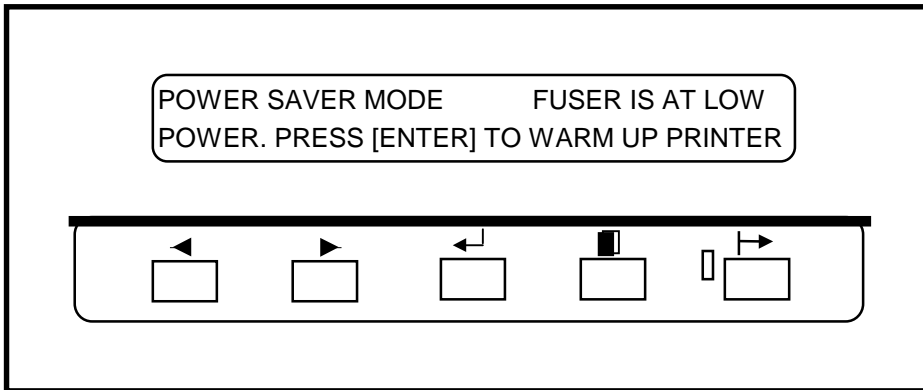

The printer will go through two stages of power conservation after a preprogrammed time interval of no print activity or control panel activity:

1) POWER SAVER MODE

Using the printer menu, you can adjust the time interval that the printer remains in the Ready mode from 5 to 50 minutes. After this preset interval, the printer will enter the Power Saver mode. Refer to the Off Line Menus section of this manual for instructions.

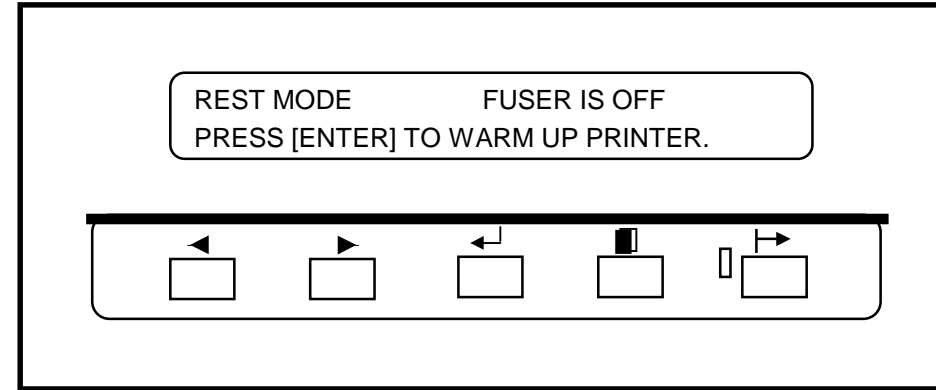

2) REST MODE

In the Rest mode, a minimum of power is supplied to the printer.

Using the printer menu, you can adjust the time interval that the printer remains in the Power Saver mode from 15 to 150 minutes. After this preset interval, the printer will enter the Rest mode. Refer to the Off Line Menus section of this manual for instructions.

A print request returns the printer to the on-line mode.

MEDIA INFORMATION

Loading the Rolls of Media

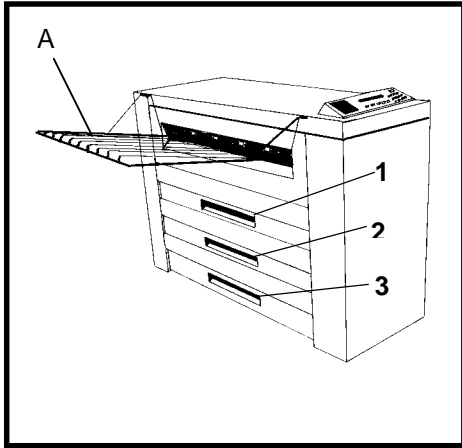

Note: Load media in the drawers before switching on the power or after the printer is ready to print.

1. Raise the output tray (A) if necessary and then lift the handle in order to pull out the Media Roll Drawer 1, 2 (Optional on 8825), or 3 (Not available on 8825).

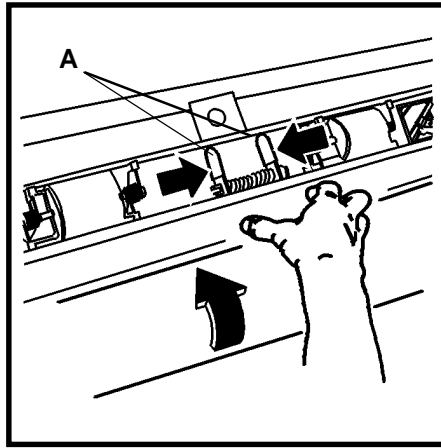

2. Squeeze the two knobs (A) together in order to release the latch.
3. Rotate the roll to rewind the remaining media onto the roll.

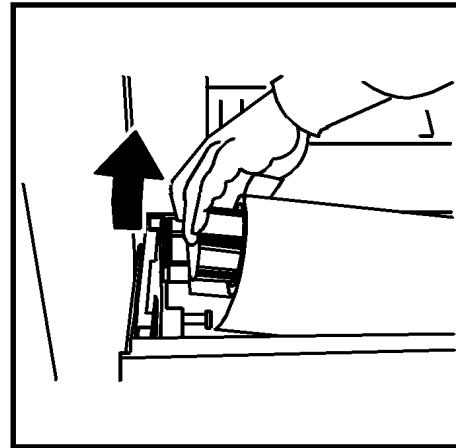

4. Lift out the used roll of media.

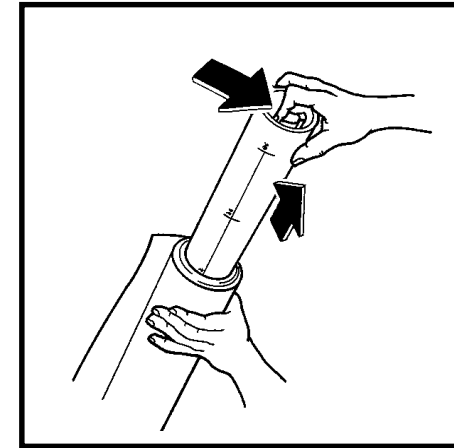

5. Stand the roll assembly on end.
6. Squeeze the lever at the end of the Media Roll Support Tube and remove the tube from the used roll of media.

MEDIA INFORMATION

Loading the Rolls of Media

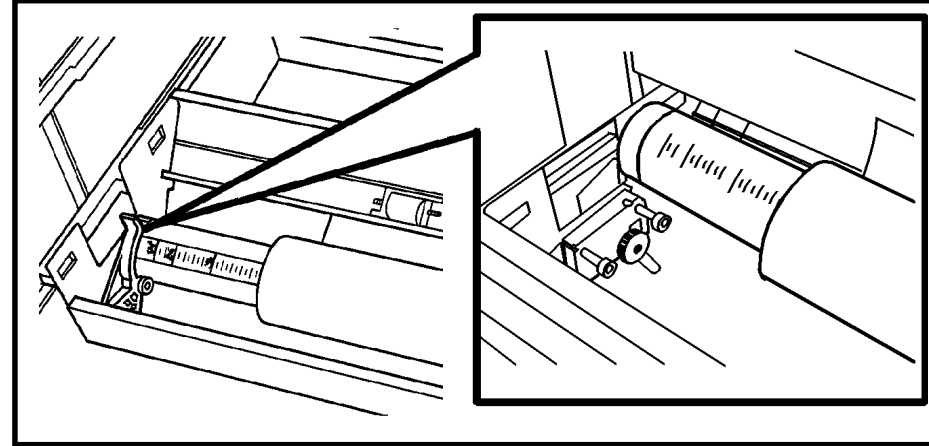
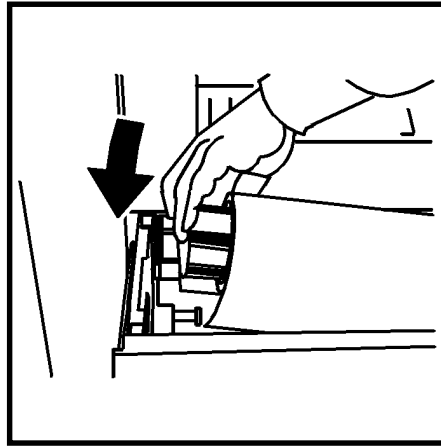
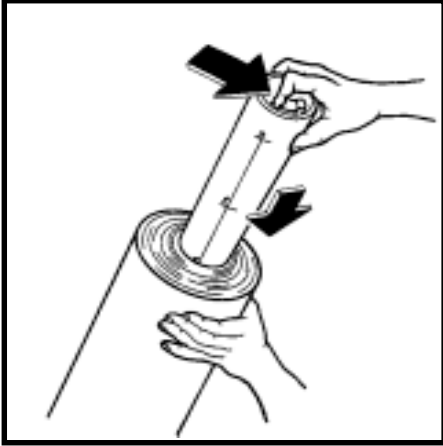

7. Slide the Media Roll Support Tube into the new roll of media.
8. Squeeze the lever at the end of the Media Roll Support Tube, and slide the tube into the roll until the size indicators on the tube match the size of the roll.

9. Lift the new roll into the media drawer, lead edge down and in.

10. Ensure that the Media Roll Support Tube is seated correctly on the support rollers.

11. Remove the tape from the lead edge of the media.

NOTE: Ensure that all of the glue from the tape is removed from the media.

MEDIA INFORMATION

Loading the Rolls of Media

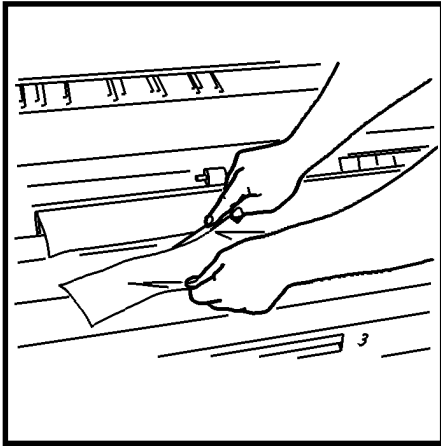

12. If the lead edge of the roll is torn or uneven, trim off the lead edge of the media.

NOTE: Trimming is usually not necessary for a new roll of media.

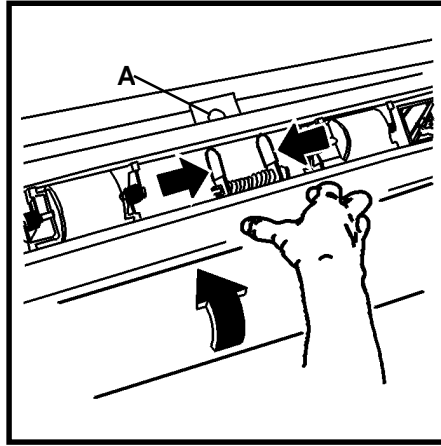

13. Squeeze the two knobs on the Baffle and lift up to open the Baffle.
14. Rotate the media roll to feed the media under the Baffle and beyond the registration window (A).

NOTE: Ensure that the lead edge of the media is flat and is not folded over itself.

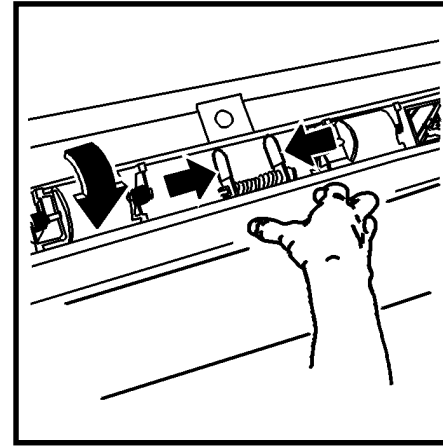

15. Squeeze the two knobs on the Baffle and lower the Baffle into place.

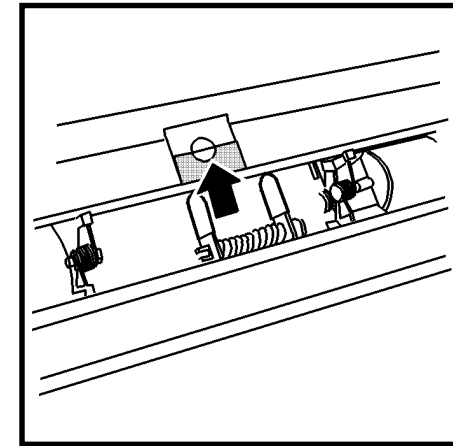

16. Center the lead edge of the media in the registration window.

MEDIA INFORMATION

Loading the Rolls of Media

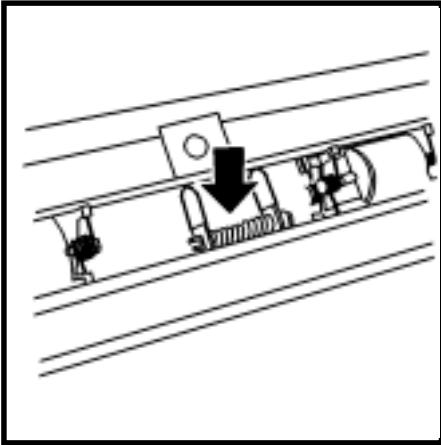

17. Press down on the center of the baffle in order to lock the Baffle into position.

NOTE: Ensure that the lead edge of the media is still aligned in the registration window.

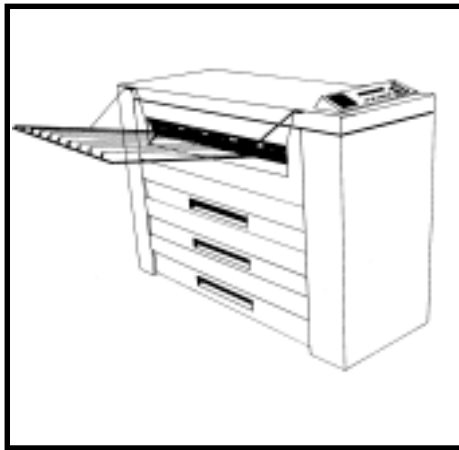

18. Push in the Media Roll Drawer.
19. Refer to instructions on the following page in order to program the Media View Menu for the media you loaded in the drawer.
20. Lower the output tray.

MEDIA INFORMATION

Media View Menu

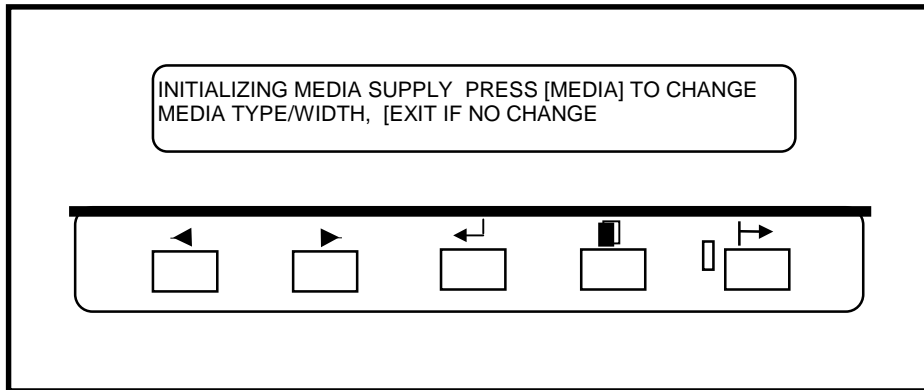

After opening a media drawer and/or loading the media, the printer message will prompt you to change the size and type of media in the Media View Menu. The Media button on the Control Panel is the means of access to the Media View Menu. The Media View Menu contains three submenus:

- Media Source
- Media Size
- Media Type

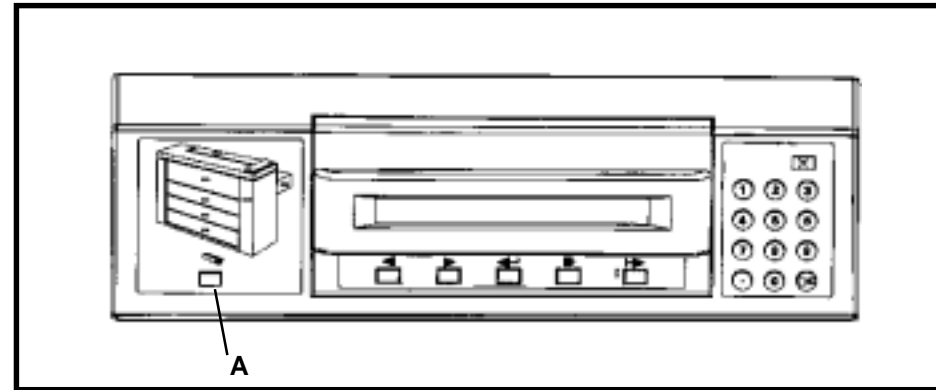

1. Press the Media button (A) in order to access the Media View Menu from the on-line or off-line mode.

MEDIA INFORMATION

Media View Menu (cont.)

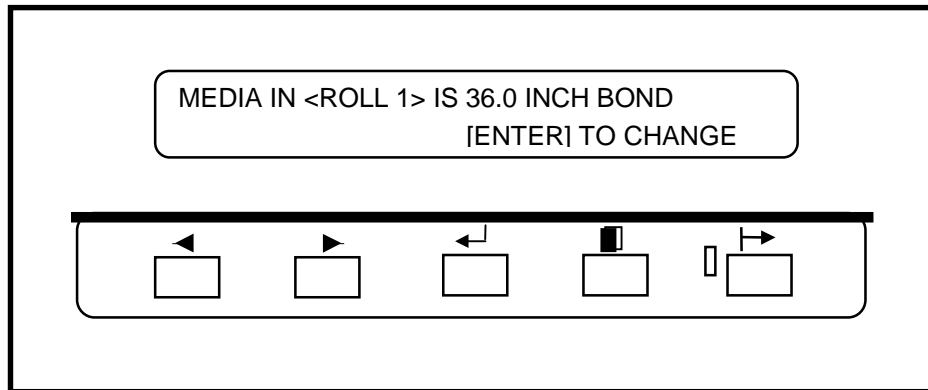

2. Press the Next or the Previous button in order to scroll through the current media selections:
 - Roll 1
 - Roll 2 (Optional on the 8825)
 - Roll 3 (Not available on the 8825)
 - Bypass Shelf (Optional on the 8825)

NOTE: Media size selection does not apply to the Bypass Shelf.

3. Press the Enter button in order to select a media source.

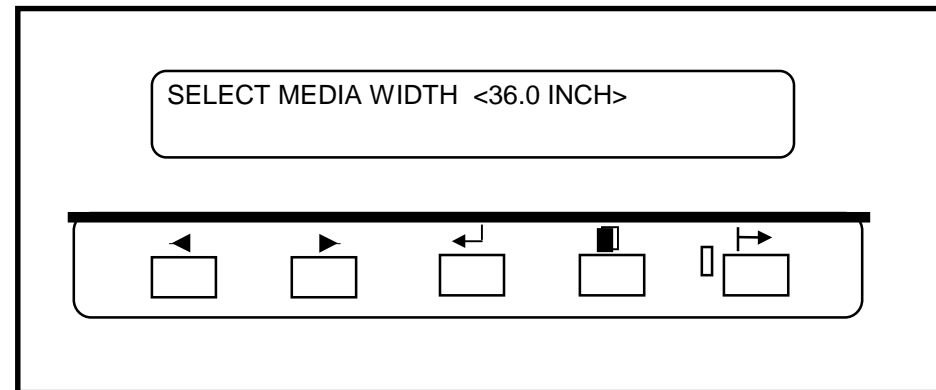

4. Press the Next or the Previous button in order to scroll through the media sizes.
 - Press the Enter button in order to select a media size:
5. Press the Exit button in order to go back to the media source selection.

<11.0 INCH>	<297 mm.>
<12.0 INCH>	<353 mm.>
<17.0 INCH>	<420 mm.>
<18.0 INCH>	<500 mm.>
<22.0 INCH>	<594 mm.>
<24.0 INCH>	<620 mm.>
<30.0 INCH>	<707 mm.>
<34.0 INCH>	<750 mm.>
<36.0 INCH>	<841 mm.>
	<860 mm.>
	<880 mm.>
	<900 mm.>

MEDIA INFORMATION

Media View Menu

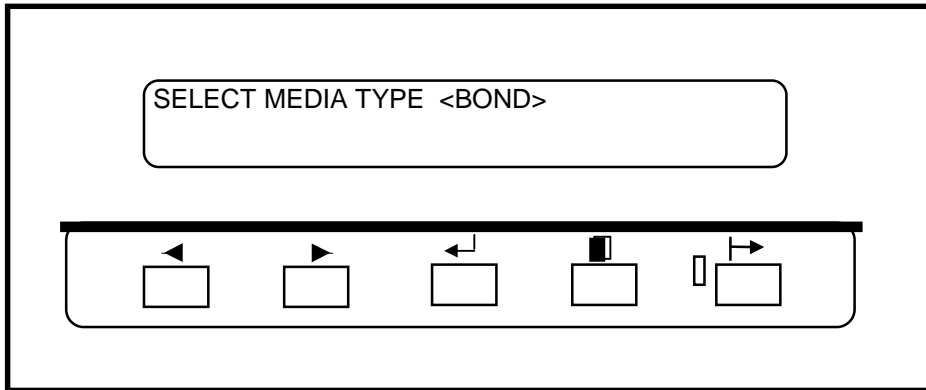

6. Press the Next or the Previous button in order to scroll through the media types:
 - Bond (ordinary)
 - Vellum/Tracing
 - Film
7. Press the Enter button in order to select the media type
8. Press the Media button in order to return to the on-line or off-line mode.

MANUAL BYPASS FEED

The Manual Bypass Feed is standard equipment for the 8830. The Manual Bypass Feed is optional equipment for the 8825

- When the correct media is not loaded for an incoming print job, you may manually bypass the media drawers and load cut-sheet media of the required size on the Cut Sheet Feed-In Shelf.
- Minimum size is 8.5 X 11 inch (A4) fed Short-Edge-Feed (SEF).

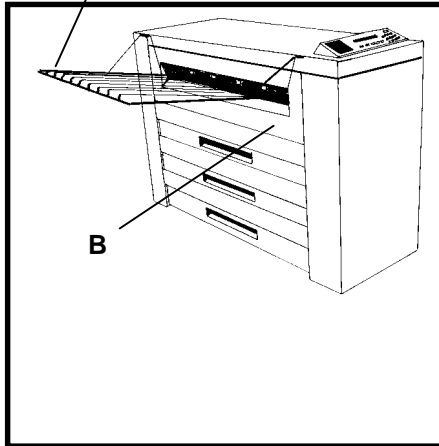

1. Raise the Output Tray (A) up and out of the way.
2. Center the media between the size indicators on the Cut Sheet Feed-In Shelf (B).
3. Feed the lead edge of the media squarely into the printer until the media stops.

OFF-LINE MENUS

Printer Menu

The printer has two off-line menus that customize the printer to meet your particular application.

The Printer Menu allows you to customize the printer to meet your special requirements. The Controller Menu (available only on Printers with a Controller installed) allows you to configure the controller to meet your specific requirements.

The Printer Menu contains six submenus, with one or more features per submenu, that allows you to control the operation of the printer:

1. Audible Indicators: This submenu has two features which activate an audible beeper for system events and keypad actuation's.
2. Timers: This submenu sets the time intervals for the Power Saver and Rest mode.
3. Printer Adjustments: The print density can be increased or decreased.
4. Finisher Settings: This submenu enables you to specify the finisher configuration type.
5. Diagnostics One of the three features allows you to run a test print in the off-line mode. Another feature displays a record of printer faults. A third feature is for use by the Service Representative and is password protected.
6. Billing Meters These two meters provide records of the length and area of prints produced.

OFF-LINE MENUS

Printer Menu - Entry

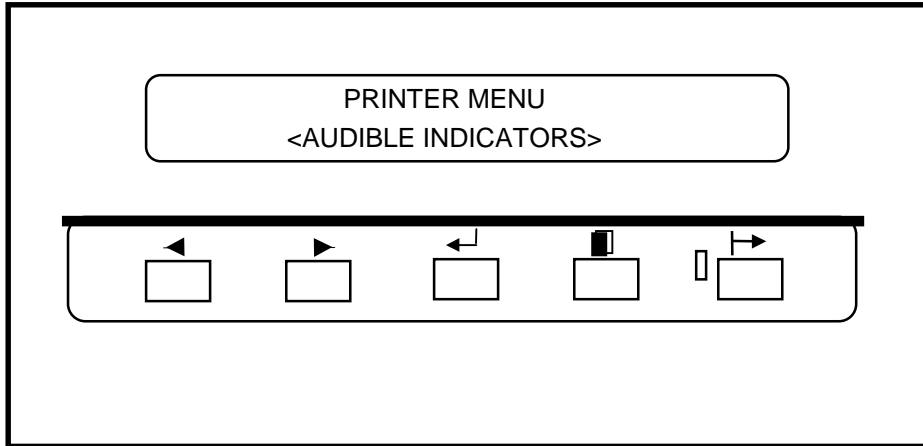

1. Press the Off-line button in order to enter the off-line mode.
 - The Message Display indicates PRINTER MENU <AUDIBLE INDICATORS>, which is the first Printer submenu.
2. Press the Next button in order to scroll through the other submenus.
3. Press the On-line button in order to return to the On-line mode.

NOTE: For printers with the Controller installed, refer to the XES Synergix 8825/8830 Controller Setup Manual to enter the Printer Menu.

OFF-LINE MENUS

Printer Menu - Audible Indicators

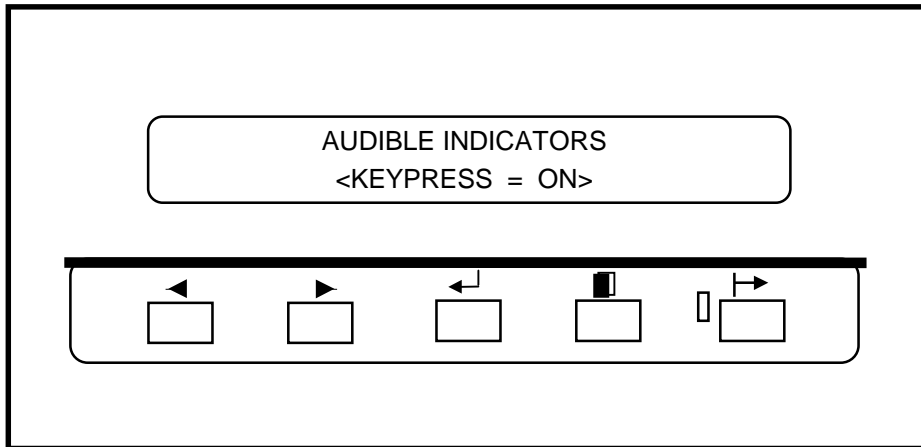

1. When <AUDIBLE INDICATORS > is displayed on the Control Panel, press the Enter button.
2. Press the Enter button to select the KEYPRESS=ON feature (or press Next to select the ALARM ON feature and go to step 6).
3. Press the Next (or the Previous) button in order to switch the feature ON or OFF.
4. Press the Enter button in order to enter your selection.
press Exit if no change is required.

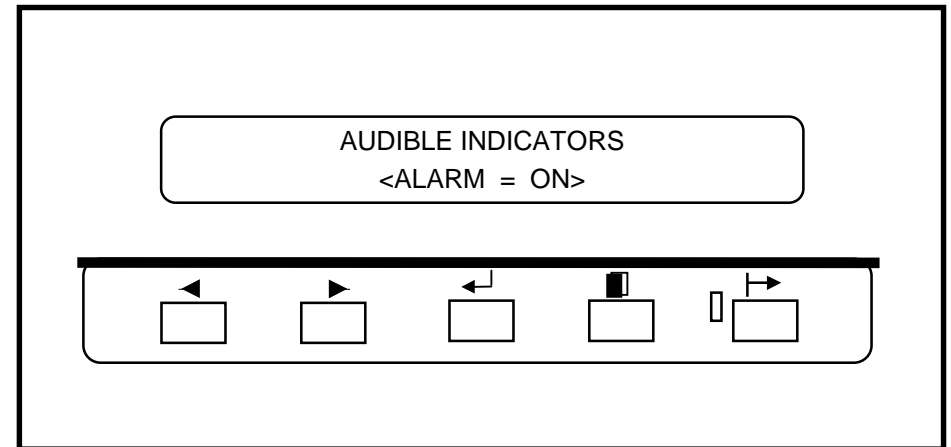

5. Press the Next button to display the next feature.
6. Press Enter to select the ALARM ON feature.
7. Press the Next (or the Previous) button in order to switch the feature ON or OFF.
8. Press the Enter button in order to enter your selection or press Exit if no change is required.
9. Press Exit to return to the AUDIBLE INDICATORS submenu.

OFF-LINE MENUS

Printer Menu - Timers

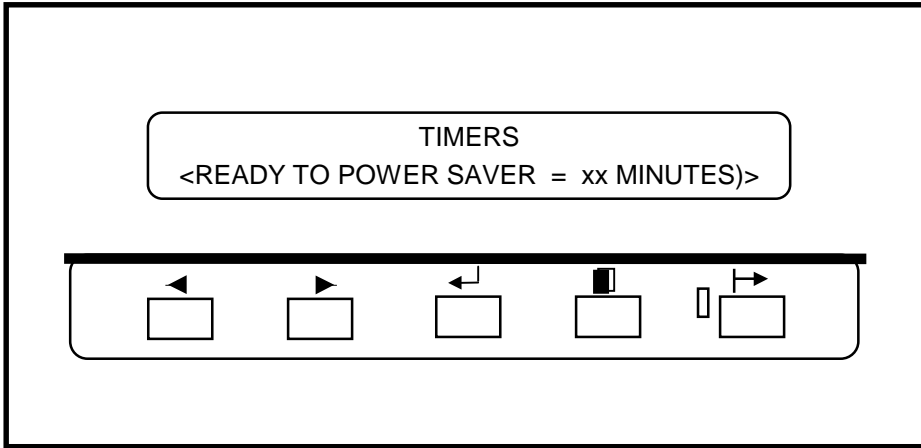

7. When TIMERS is displayed on the Control Panel, press the Enter button to display the first feature.
8. Press the Enter button to select the READY TO POWER SAVER feature (or press Next to select the (next) TIMERS feature and go to step 6 to select the next feature).

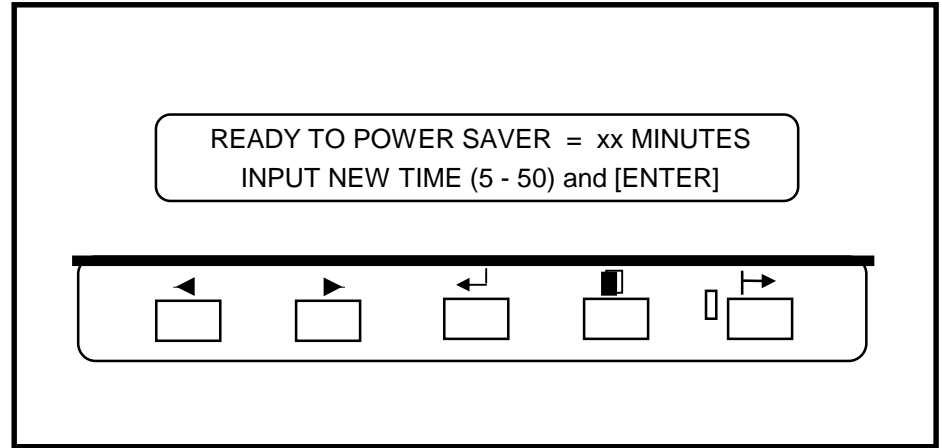

3. Press the Next (or Previous) button in order to scroll through the range of values (the value of 0 will prevent the printer from entering the Power Saver mode).
4. Press the Enter button in order to enter your selection or press Exit if no change is required.
5. Press the Next button to display the next feature.

OFF-LINE MENUS

Printer Menu - Timers (cont.)

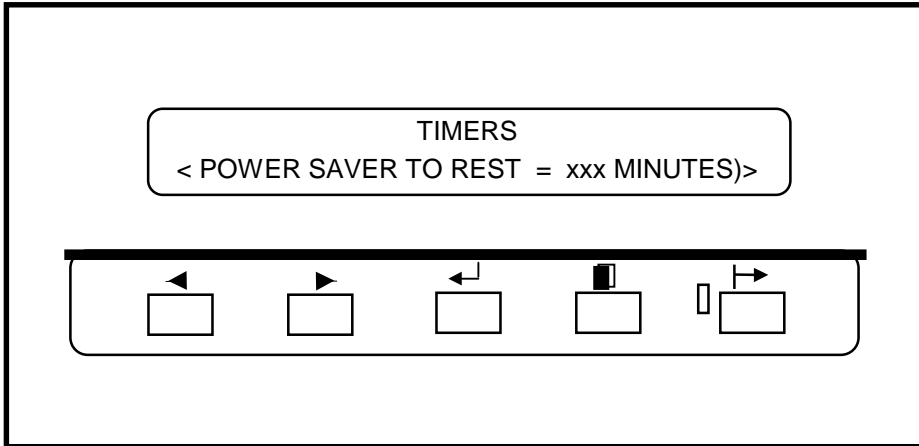

11. Press Enter to select the POWER SAVER TO REST feature.

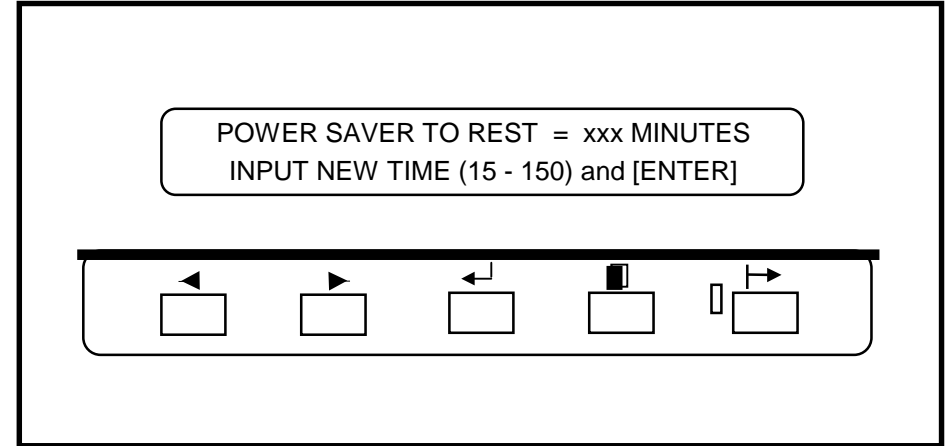

7. Press the Next (or Previous) button in order to scroll through the range of values.
8. Press the Enter button in order to enter your selection or press Exit if no change is required.
9. Press the Exit button in order to return to the TIMERS submenu.

OFF-LINE MENUS

Printer Menu - Printer Adjustments

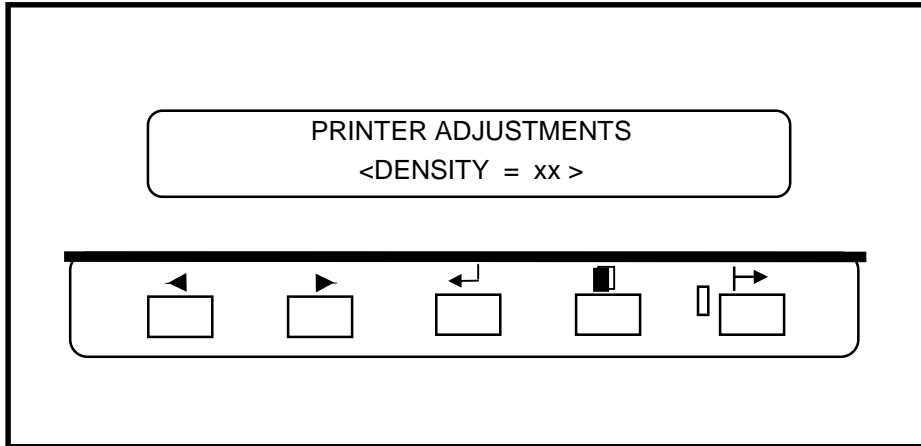

7. When PRINTER ADJUSTMENTS is displayed on the Control Panel, press the Enter button to display the first feature.
8. Press the Enter button to select the DENSITY feature.

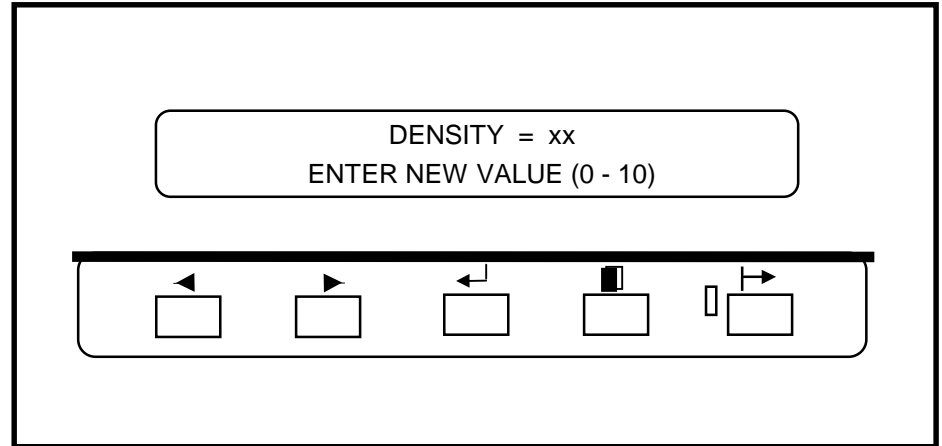

3. Press the Next (or Previous) button in order to scroll through the range of values.
4. Press the Enter button in order to enter your selection or press Exit if no change is required.
5. Press the Exit button in order to return to the PRINTER ADJUSTMENTS submenu.

OFF-LINE MENUS

Printer Menu - Finisher Settings

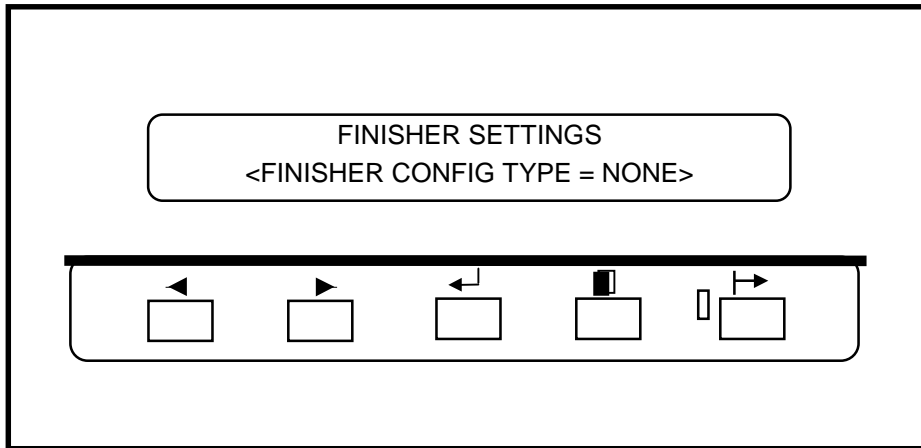

7. When FINISHER SETTINGS is displayed on the Control Panel, press the Enter button to display the first feature.
8. Press the Enter button to select the FINISHER feature, or go to step 5 to select the next feature.

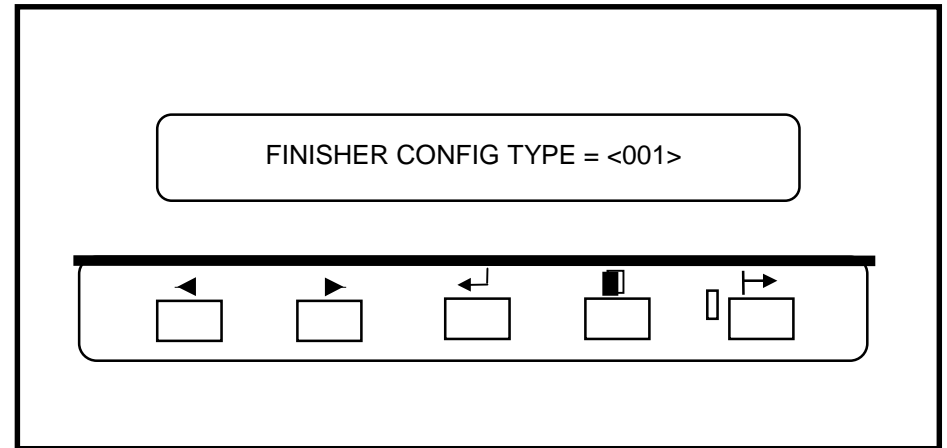

3. Press the Next (or the Previous) button in order to scroll through the available settings.
4. Press the Enter button in order to enter your selection, or press Exit if no change is required.

NOTE: Refer to the Folder User Guide for the appropriate value.

5. Press the Exit button in order to return to the FINISHER SETTINGS submenu.

OFF-LINE MENUS

Printer Menu - Diagnostics

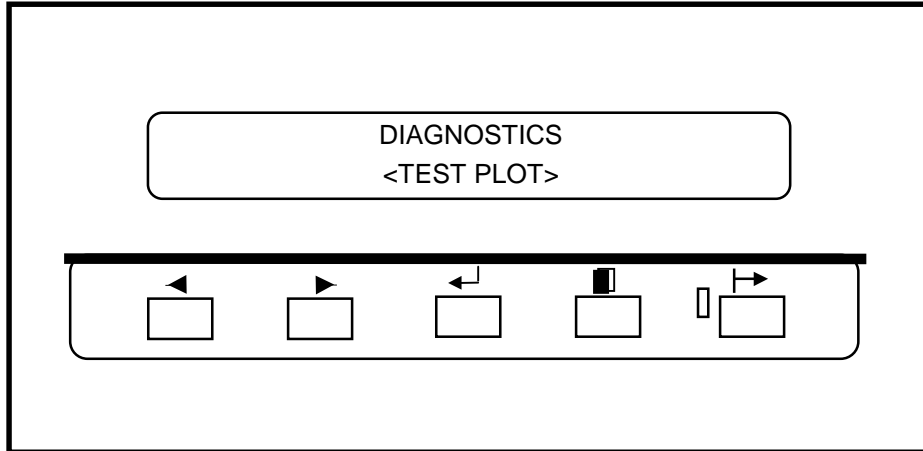

1. When DIAGNOSTICS is displayed on the Control Panel, press the Enter button to display the first feature.
2. Press the Enter button to select the <TEST PLOT> feature.

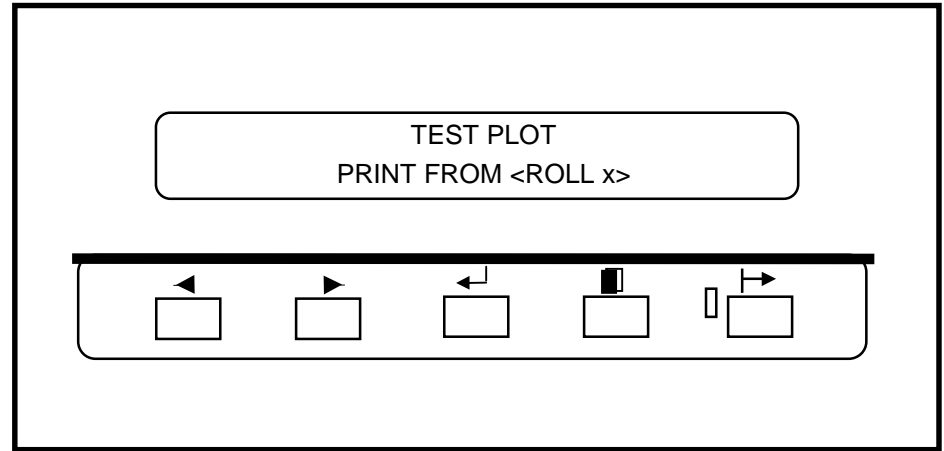

3. Press the Next (or Previous) button in order to scroll through the available settings (Roll 1, Roll 2 (Optional for the 8825), Roll 3 (Not available for the 8825), BYPASS (Optional for the 8825)).
4. Press the Enter button in order to enter your selection, or press Exit if no change is required.
5. Press the Exit button in order to return to the DIAGNOSTICS submenu.

NOTE: There are two other features in the submenu that are reserved for the Service Representative. The diagnostic feature is protected by a password.

OFF-LINE MENUS

Printer Menu - Billing Meters

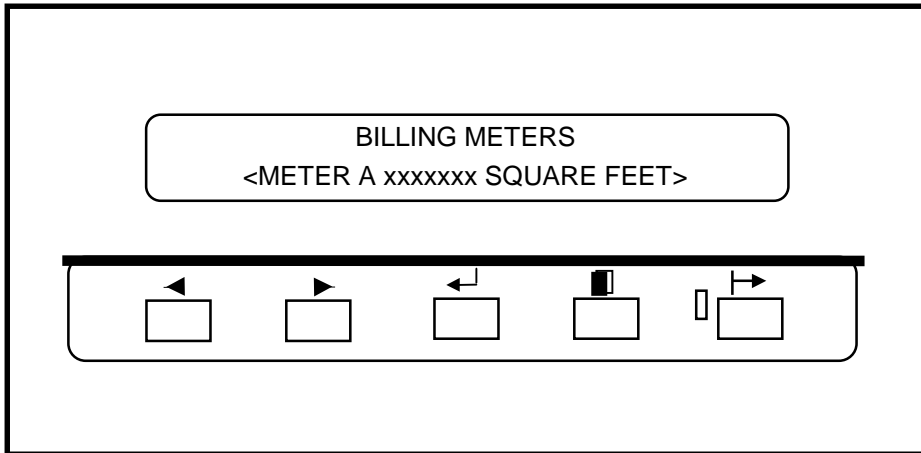

1. When BILLING METERS is displayed on the Control Panel, press the Enter button to display the Meter A. screen.
2. Press the Enter button to view to total count of Meter A.
3. Press Exit to return to the Printer Menu.

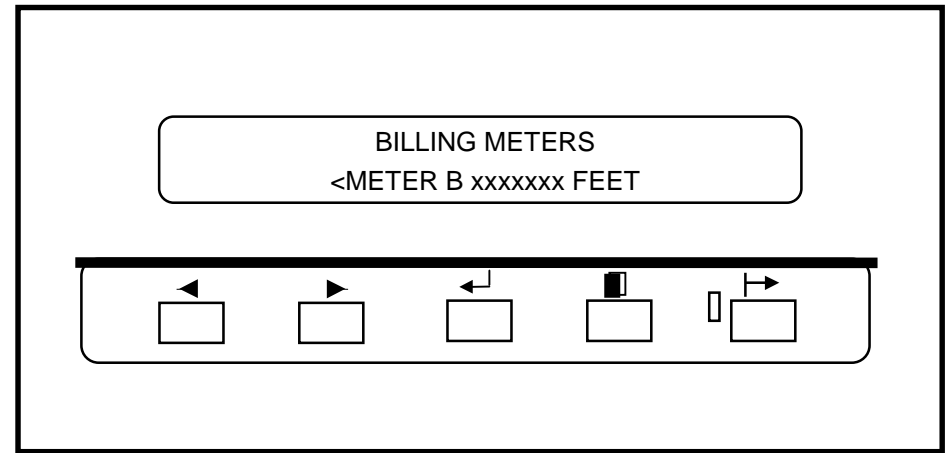

4. Press the Next (or the Previous) button to display the total count of Meter B.
5. Press the Exit to return to the Printer Menu.

PROBLEM SOLVING

Status Codes

The Printer has been designed with the user in mind; therefore, very few problems will be encountered. But, should the printer not operate correctly, it has the ability, in most cases, to advise the user how to solve the problem. The Control Panel displays advise the user of problems and how to correct them.

- The Graphic Fault Display flashes the appropriate LED(s) at the location of any problems.
- The Message Display shows the Status Code that is associated with any problem. The Message Display also shows the instructions for correcting the problem.

When a problem occurs, take the following actions:

- Observe the Control Panel displays.
- Observe the location of any flashing indicators on the Graphic Fault Display and follow the instructions on the Message Display.
- If a Status Code is present on the Message Display, refer to the table on this page for further corrective action.
- If the problem or malfunction continues, call for service.

Status Codes

The following Status Codes may appear on the Message Display. Follow the instructions in the table below before calling for service.

Status Code	Explanation
C0.--	This code indicates a cutter problem. Follow the instructions on the Message Display.
C1.--	This code indicates a problem with Roll 1. Follow the instructions on the Message Display.
C2.--	This Code indicates a problem with Roll 2 (Optional for the 8825). Follow the instructions on the Message Display.
C3.--	This code indicates a problem with Roll 3 (Not available on the

	8825). Follow the instructions on the Message Display.
C4.--	This code indicates a problem at the Cut Sheet Bypass (Optional for the 8825). Follow the instructions on the Message Display.
E2.--	This code indicates a problem in the paper path. Follow the instructions on the Message Display.
E4.--	This code indicates a problem in the fuser area. Follow the instructions on the Message Display.
E5.--	This code indicates an interlock problem. Follow the instructions on the Message Display.
E6.--	This code indicates a problem in the paper path. Follow the instructions on the Message Display.
E7.--	Communication failure with the Controller. Switch the printer and controller off, wait a few seconds, then switch them on.
E9.--	Switch the printer off. Wait a few seconds, then switch the printer on.
F1.--	This code indicates a problem in the finisher. Follow the instructions on the Message Display.
F2.--	This code indicates a problem in the finisher. Follow the instructions on the Message Display.
J1.01	This code indicates that the Toner Cartridge should be replaced. Refer to the CARE section, Replacing the Toner Cartridge.
J2.02	This code indicates that the Toner Cartridge is not installed correctly. Refer to the CARE section, Replacing the Toner Cartridge.
LL.--	Switch the printer off. Wait a few seconds, then switch the printer on.
U1.01	Call for service.

PROBLEM SOLVING

Media Jams

When a media jam occurs, the printer stops.

The Graphic Fault Display flashes an LED in the area where the fault has occurred. At the same time, a Status Code appears on the Message Display. The Message Display will also show the correct action to take in order to clear the jam:

1. Follow the instructions on the Message Display.
2. If the jammed media is visible, try to pull the media gently out of the printer and discard the media.
 - If the media cannot be removed easily, or if it tears and only part of the sheet is removed, continue with this procedure.

WARNING

Do not touch the fuser (red) roll inside the printer while performing the following steps. The fuser roll is very hot and can cause severe burns.

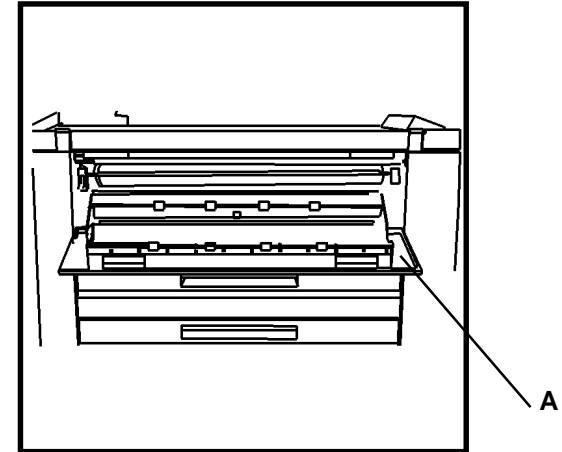

3. Lower the Cut Sheet Media Shelf (A).
4. Reach carefully into the printer and remove the jammed media.
5. If the media has been torn, remove all of the pieces.
6. After all of the jammed media has been removed, close the shelf/cover and go to step 8.
7. If the jammed media is not visible from the left side of the printer, close the shelf/cover and go to the right side of the printer.

PROBLEM SOLVING

Media Jams

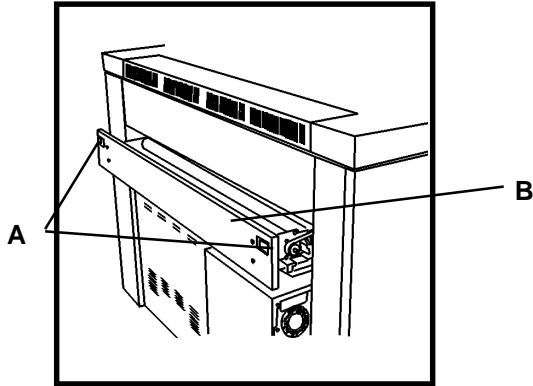

8. Unlatch (A) and open (B) the Cutter Drawer.
9. Locate and remove any media from the Cutter area.
10. Close the Cutter Drawer.
11. The printer will resume printing when all jam locations have been cleared. If the problem continues, call for service.

Error Messages

ERROR MESSAGE	PROBLEM	SOLUTION
CHECK FOLDER FOLDER COMMUNICATIONS ERROR #17	Finisher Config Type enabled but no folder is installed.	<ol style="list-style-type: none"> 1. Press the ONLINE/OFFLINE button to take the printer OFFLINE. 2. Refer to Finisher Settings on page 27 and reset the value to NONE
F2-01 CHECK FOLDER FOLDER COMMUNICATIONS ERROR #01	Finisher Config Type enabled but no folder is installed.	<ol style="list-style-type: none"> 1. Switch OFF the Printer. 2. Wait 5 seconds and switch ON the printer 3. As soon as the Printer Firmware Version message is displayed, press the ONLINE/OFFLINE button to take the printer OFFLINE. 4. Refer to Finisher Settings on page 27 and reset the value to NONE

PROBLEM SOLVING

Checking for Loss of Power

If there is a loss of power to the printer, go to the right side of the printer and locate the point where the power cord goes into the printer. Next to the power cord is a Ground Fault Protector, as shown in the illustration. Ensure that the power cord is plugged into the wall outlet and follow the instructions on the label (A).

If power is not restored after you have followed the instructions, call for service.

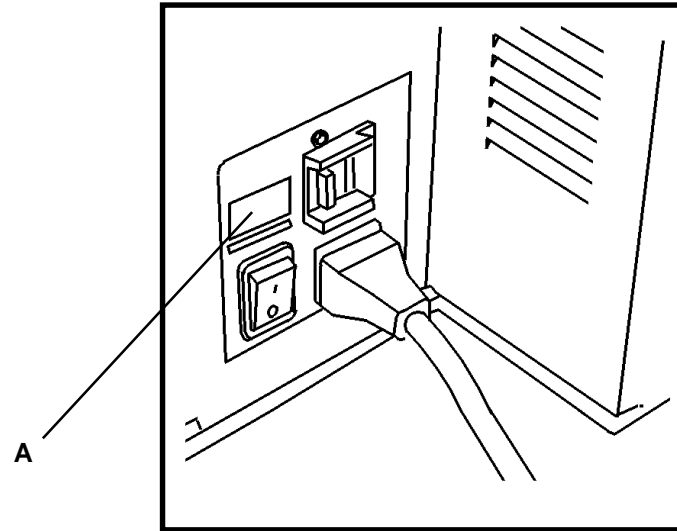

PROBLEM SOLVING

Print Quality

Problem	What to Do
Prints are partially deleted.	If the media is damp, replace it.
Prints are light overall.	Go to the Printer Menu , Printer Adjustments, and adjust the density.

Media Tips

- Close and seal the media package when the media is not in use.
- Store the media in a cool, dry environment.
- Store roll media on end.
- Store the cut sheet media flat, not on edge.

For reliable printer operation and print quality, the following types of print media are recommended:

NOTE: Be sure to set up the Media View Menu according to the size and type of media you are using.

- **BOND PAPER:** Substance 20 to substance 24 xerographic roll paper or cut sheets are recommended for normal usage.
- **VELLUM:** Substance 20 vellum is recommended.
- **FILM:** 4 mil thickness, double matte, heat stable film is recommended.

CARE

Replacing the Toner Cartridge

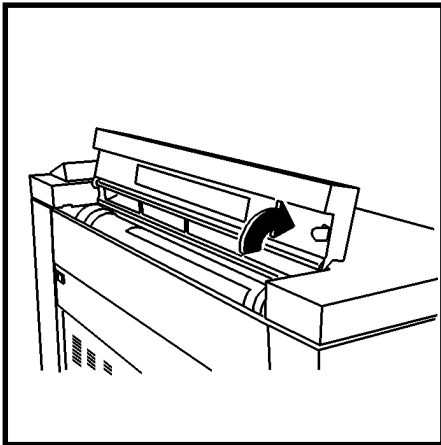

1. Open the Toner Supply Access Cover.

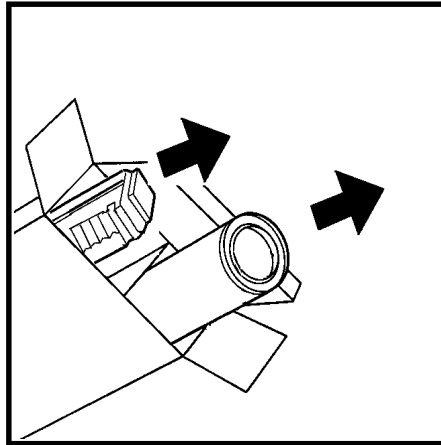

2. Open the Toner Replacement package.
 - Remove the Toner cartridge replacement.
 - Remove the Toner Waste Bottle.

CAUTION

Toner identified for use in the XES Synergix 8825/8830 Printer is a two-component material made specifically for this printer. Use of Toner that is not indicated for the XES Synergix 8825/8830 Printer will cause damage to the printer.

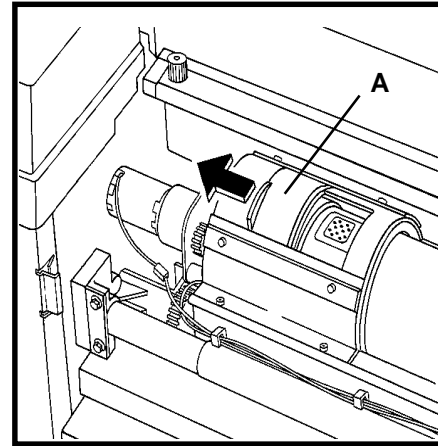

3. Slide door (A) in the direction shown in order to expose the dispenser patch.

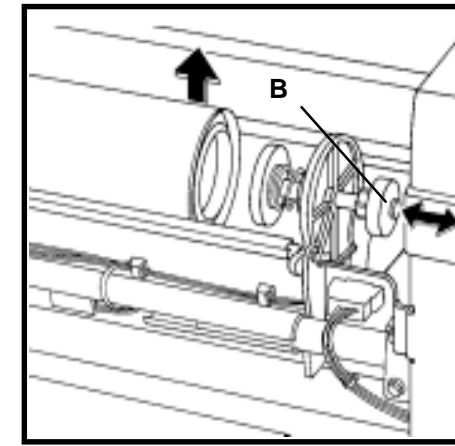

4. Pull the plunger (B) and lift the front end of the Toner Cartridge.
5. Release the plunger and rest the cartridge on the plunger mechanism

CARE

Replacing the Toner Cartridge

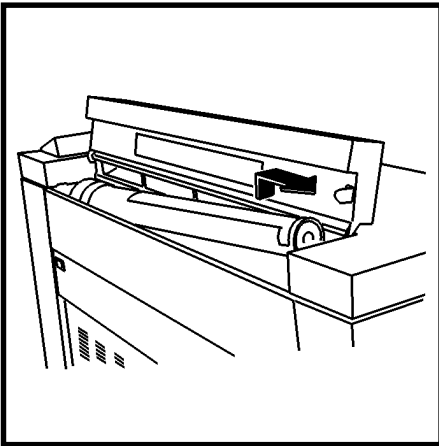

6. Lift the used Toner Cartridge out of the printer; try not to tilt the cartridge too much in order to avoid spilling toner.

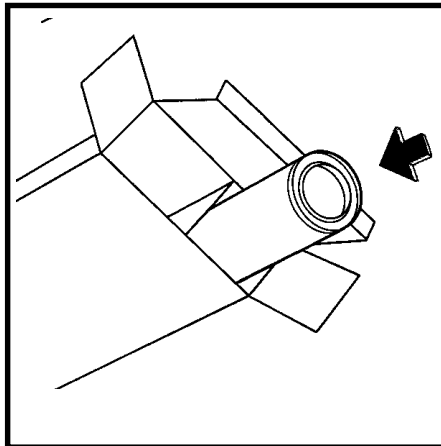

7. Discard the used Toner Cartridge in the Toner Replacement package.

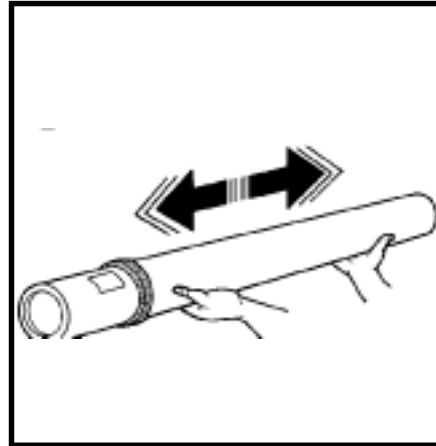

8. Hold the new Toner Cartridge horizontally and shake it side to side 10 or 12 times, as shown above.

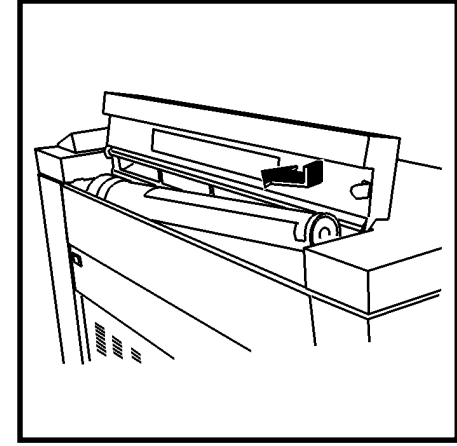

9. Install the end of the cartridge with the red cover tape into the rear of the printer.

NOTE: Ensure that the red cover tape is facing up.

CARE

Replacing the Toner Cartridge

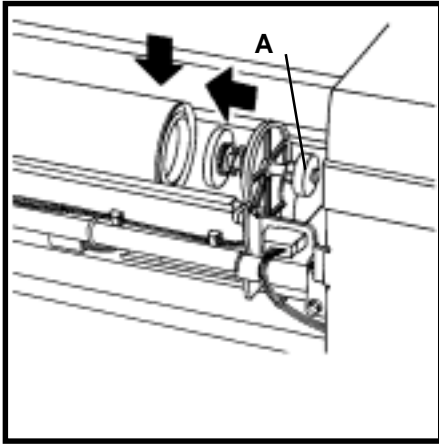

10. Lower the Toner Cartridge into position while pushing the plunger (A) toward the front of the printer, then release the plunger.
11. Rotate the Toner Cartridge back and forth until the cartridge locks into position in the rear drive collar.

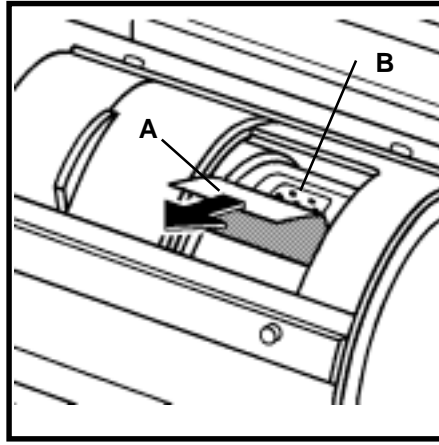

CAUTION

Remove the red cover tape carefully. Do not remove the clear, perforated seal.

12. Remove the red cover tape (A) from the Toner Cartridge; do not remove the seal (B) under the tape.

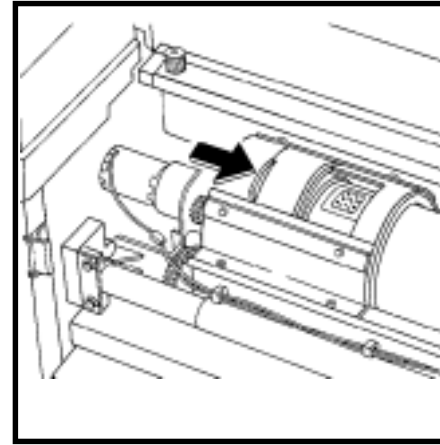

13. Close the cover.

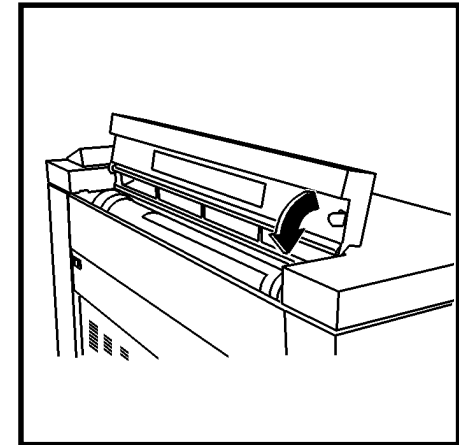

14. Close the Toner Supply Access Cover on the printer.

CARE

Replacing the Toner Waste Bottle

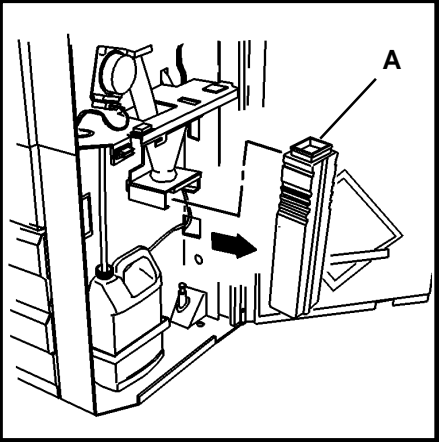

1. Open the Front Door and remove the Toner Waste Bottle (A).

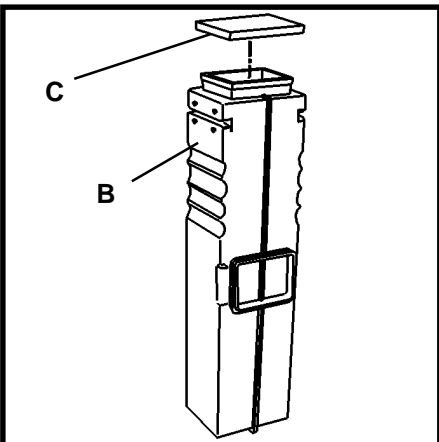

2. Seal the used Toner Waste Bottle (B) with the stopper (C) attached to the side of the bottle.

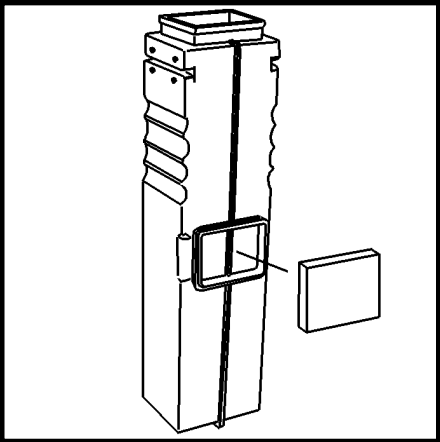

3. Attach the stopper to the side of the new Toner Waste Bottle.
4. Install the new Toner Waste Bottle.
5. Close the Front Door.

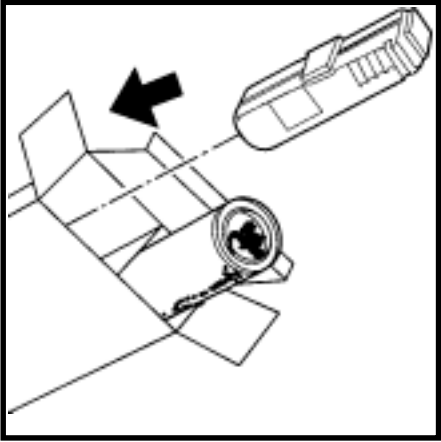

6. Discard the used Toner Waste Bottle in the Toner Replacement package and dispose of the package in an approved waste container.

CARE

Required Tasks

Perform the following tasks, as required:

CAUTION

Toner identified for use in the XES Synergix 8825/8830 Printer is a two-component material made specifically for this printer. Use of Toner that is not indicated for the XES Synergix 8825/8830 Printer will cause damage to the printer.

- Replace the Toner Waste Bottle each time a new Toner Cartridge is installed. Refer to Replacing the Toner Cartridge in this section of the operator manual.

CAUTION

Do not reuse the contents of the Toner Waste Bottle. Reuse of this material will cause damage to the printer.

- Empty the water periodically from the collection bottle located inside the Front Door of the printer.
- Clean the outside surfaces of the printer, using a cleaning cloth dampened with mild soap and water. Do not pour or spray liquid directly on to any part of the printer.

Calling for Service

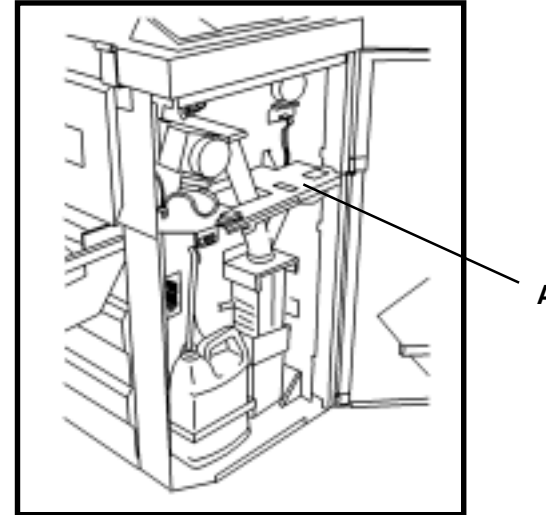

When a Status Code appears on the Message Display and the problem that caused it is not cleared by following the instructions shown on the Message Display, call for service after first taking the following steps:

1. Write down the Status Code and any message on the Message Display, note any flashing LED indicators, and a brief description of the problem.
2. The Serial Number (A) can be found inside the front cover of this manual, or open the Front Door of the printer and refer to the illustration above to locate and write down the serial number.
3. If print quality is the problem, take a print sample to the phone with you in order to help in describing the problem.
4. Refer to the inside of the front cover of this manual for the local number to call for service.

CARE

Ordering Supplies

When ordering supplies, please be prepared to give the following information:

- Your equipment model number: XES Synergix 8825/8830 Printer
- Your XES customer number: _____
- Item description and quantities required

Supplies Order List

- Toner Cartridge and Toner Waste Bottle (part number 6R891, Europe 6R90268)

CAUTION

Toner identified for use in the XES Synergix 8825/8830 Printer is a two-component material made specifically for this printer. Use of Toner that is not indicated for the XES Synergix 8825/8830 Printer will cause damage to the printer.

- Xerox papers, vellums, and film are available in various sizes, weights, and grades to meet your printing needs.

Pre-packaged Supplies

- **8830:** Two Toner Cartridges (one installed) and one Toner Waste Bottle have been shipped with the printer for your convenience at installation.
- **8825:** One Toner Cartridge and Waste Bottle are provided, installed in the printer.

Product Specifications

XES Synergix 8825/8830 Printer

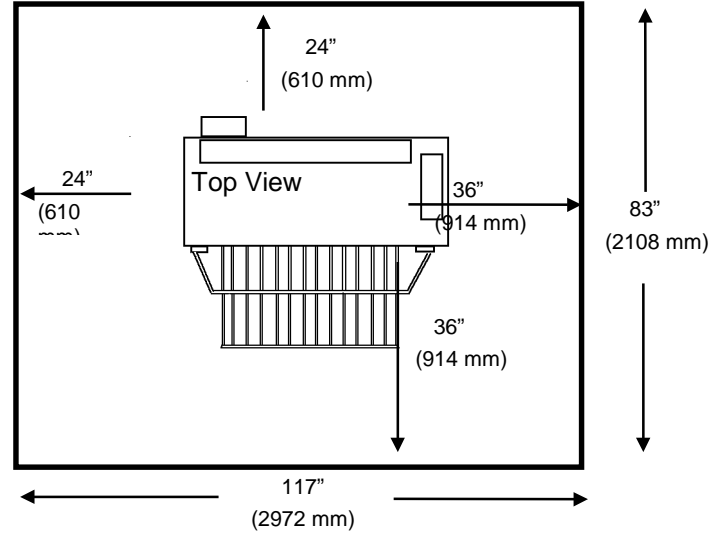
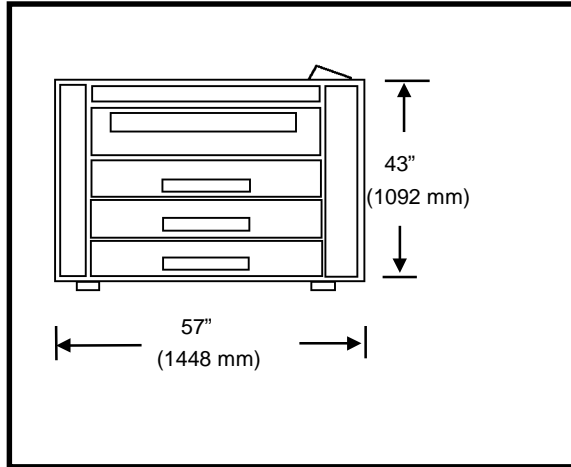

Printer Dimensions

Weight: 8830: 650 lbs. (295kg)

8825 (1 drawer): 620 lbs (281kg)

8825 (2 drawer): 635 lbs (286kg)

Height: 43 inches (1092 mm)

Width: 23 inches (584 mm)

Depth: 57 inches (1448 mm)

Minimum Room Space Requirements

Product Specifications

XES Synergix 8825/8830 Printer

Electrical Specifications

105 - 125 VAC (Nominal 60 Hz)
 210 - 225 VAC (Nominal 50 Hz)
 20 Amp dedicated circuit

Power Consumption

120 Watts: (Power Saver Mode)
 1000 Watts (heaters on - standby)
 690 Watts (Ready Mode)
 1840 Watts (running)

Heat Dissipation

6,270 BTU (running)
 Warm-up Time: 2 minutes

Environmental Requirements

Temperature: 60° F (10° C) to 80° F
 (27° C)
 Humidity: 20% to 80% Relative
 Humidity
 Maximum Elevation: 7000 feet (2133 m)
 above sea level

Media Specifications:

Media Type:

Bond (20 lb.)
 Vellum (20 lb.)
 Film (4 mil.)
 Tracing (4 mil)

Media Size:

Roll Feed - 11 inches to 36 inches (279.4 mm to 914.4 mm) width (3 (76.2 mm) inches core diameter to 6.7 inches (170.2 mm) O.D.) (Roll 2 is optional for the 8825, Roll 3 is not available for the 8825).

Manual Bypass Feed (optional for the 8825) - 11 inch to 36 inch (279.4 mm to 914.4 mm)

Print Size:

Minimum Cut Sheet - 8.5 X 11 inches (216 mm x 279 mm)

Minimum Roll Feed - 11 X 8.5 inches (279 mm x 216 mm)

Maximum Length - 48ft, (15.2 m) (Standard with the 8825/8830 Controller) 80 ft (24.4 m) (Optional)

Audible Noise

67 dBA) Maximum

Product Specifications

XES Synergix 8825/8830 Printer

8825 Prints per Minute (Bond Media):

Size	Portrait	Landscape
E/A0	2.0	--
D/A1	3	4.0
C/A2	4.1	5.5
B/A3	6.2	8
A/A4	--	8

First print out time for a D (A1) size print is 20 seconds.

8830 Prints per Minute (Bond Media):

Size	Portrait	Landscape
E/A0	3.0	--
D/A1	4.5	6.0
C/A2	6.0	8.0
B/A3	8.5	11.0
A/A4	--	11.0

First print out time for a D (A1) size print is 20 seconds

Prepared by:
Xerox Corporation
Global Knowledge & Language Services
800 Phillips Road
Building 845-17S
Webster, New York 14580-9791
USA

©2000 XEROX CORPORATION. All rights reserved.

Printed in the United States of America.

XEROX[®], XES[™], Synergix[™], and the digital box icon, AccXes, and acronym, XES are trademarks of Xerox Corporation. ©XES Systems Inc. 2000. All other product names mentioned herein are trademarks of their respective companies. All rights reserved.

701P19710

November 2000

Prepared by:
Xerox Corporation
Global Knowledge & Language Services
800 Phillips Road
Building 845-17S
Webster, New York 14580-9791
USA

©2000 XEROX CORPORATION. All rights reserved.

Printed in the United States of America.

XEROX[®], XES[™], Synergix[™], and the digital box icon, AccXes, and acronym, XES are trademarks of Xerox Corporation. ©XES Systems Inc. 2000. All other product names mentioned herein are trademarks of their respective companies. All rights reserved.