

Xerox DocuPrint  
C55/C55mp  
Color Laser Printer  
User's Guide

Copyright protection claimed includes all forms and matters of copyrightable materials and information now allowed by statutory or judicial law or hereinafter granted, including without limitation, material generated from the software programs which are displayed on the screen such as styles, templates, icons, screen displays, looks, etc.

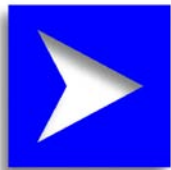
Printed in the United States of America.

XEROX® and all Xerox product names and product numbers mentioned in this publication are registered trademarks of the Xerox Corporation. Other company trademarks are also acknowledged. PCL is a trademark of the Hewlett-Packard Company. MS, MS-DOS, Windows NT, Microsoft LAN Manager, and Windows 95 are trademarks of Microsoft Corporation. Adobe, Adobe Type Manager, Adobe PageMaker, and PostScript are trademarks of the Adobe Systems, Inc. TrueType and Apple ColorSync are trademarks of Apple Computer, Inc. OS/2 is a trademark of International Business Machines Corporation. SunOS and Solaris are trademarks of Sun Corporation. MacroMedia FreeHand is a trademark of MacroMedia Corporation. QuarkXpress is a trademark of Quark Corporation.

This printer contains an emulation of the Hewlett Packard PCL 5C command language (recognized HP PCL 5C commands) and processes these commands in a manner compatible with Hewlett Packard Laserjet printer products.

Changes are periodically made to this document. Technical updates will be included in subsequent editions.

© 1996 by Xerox Corporation.  
All rights reserved.



# Table of Contents

---

## Chapter 1: Introduction

What Is In This Guide .....	1-2
Conventions Used .....	1-5
Where To Go For More Information .....	1-7

## Chapter 2: Introduction to Your C55 Printer

Printer Features .....	2-3
Print Speed.....	2-3
Resolution.....	2-4
Resident Fonts.....	2-4
Connectivity.....	2-5
Color Matching Systems.....	2-6
Printer Driver Software .....	2-7
Printer Components—External .....	2-8
Printer Components—Internal.....	2-13

**Chapter 3: Print Media**

Loading the Media Tray .....	3-4
How to Load the Tray With Paper .....	3-4
How to Load the Tray With Letterhead Paper .....	3-6
How to Load the Tray With Transparencies .....	3-7
The Manual Feed Slot.....	3-8
The Manual Feed Tray .....	3-9
How to Attach the Manual Feed Tray .....	3-10
How to Use the Manual Feed Slot.....	3-11

**Chapter 4: The Control Panel**

Control Panel Components.....	4-2
Control Panel Indicator Lights .....	4-4
Control Panel Buttons .....	4-5
Control Panel Use.....	4-7
Menu System Navigation.....	4-7
Control Panel Menus .....	4-9
The Top Menus.....	4-9
Specific Examples of Control Panel Use .....	4-13
Using the Optional Media Server .....	4-18
Print to File .....	4-19
How to Print From the Media Server .....	4-20

## Chapter 5: Special C55 Printer Driver Options

PostScript vs. PCL 5C Printer Driver Feature Comparison.....	5-3
PCL 5C Printer Driver Features.....	5-4
Color Settings (Xerox Features tab).....	5-4
Edge Smoothing (Xerox Features tab).....	5-6
Enhanced Alignment (Xerox Features tab).....	5-6
Tray Switching (Paper tab).....	5-6
Hold Job (Paper tab).....	5-6
Document Halftones (Xerox Features tab).....	5-7
Expert Color Control.....	5-8
Save Settings.....	5-10
Restore Settings.....	5-10
PostScript Printer Driver Features.....	5-11
Output Modes.....	5-11
Color Settings.....	5-13
Document Halftone.....	5-16
Expert Color Control.....	5-17
Save Settings.....	5-19
Restore Settings.....	5-19
Advanced Features.....	5-20
ImageFix (Windows 95 PostScript only).....	5-21

## Chapter 6: Troubleshooting

Before You Begin Troubleshooting .....	6-2
Hardware .....	6-2
Software .....	6-3
Printer Maintenance .....	6-3
Consumables.....	6-3
Error Messages .....	6-4
How to Clear A Media Jam.....	6-11
Media Jam Areas.....	6-12
Fuser/Output Area Jam .....	6-13
Input/Transfer Drum/Print Drum Area Jam .....	6-15
Tray/Manual Feed Slot Jam.....	6-17
Print Defects .....	6-18
Additional Sources of Troubleshooting Assistance.....	6-24

## Chapter 7: Printer Maintenance

Regular Printer Maintenance.....	7-2
Density and Color Balance Adjustment Procedure .....	7-3
Printing a Test Page .....	7-3
What To Look For .....	7-5
Making an Adjustment .....	7-6
Adjustment Recovery .....	7-7
Cleaning Procedures .....	7-8
Cleaning the Print Drum Charger.....	7-8
Cleaning the Grounding Roller and Feed Rollers .....	7-9

**Chapter 8: Optional Equipment**

Available Optional Equipment .....	8-2
How to Install Additional Memory .....	8-5
Memory Upgrade for the C55 .....	8-6
Memory Upgrade for the C55mp .....	8-6
Memory Installation Procedure .....	8-8
Memory Upgrade Options.....	8-9

**Chapter 9: Network Printer Services****Appendix A: Safety Notes****Appendix B: Special Notices****Appendix C: Printer Technical Specifications****Index**







## CHAPTER 1

# Introduction

---

- What Is In This Guide
- Conventions Used
- Where To Go For More Information

This *User's Guide* is designed to help you become familiar with all of the powerful features of your C55/C55mp Color Laser Printer, and contains information about all possible configurations. Your printer may or may not have all of the options discussed. All options can be added to your C55/C55mp. See “Chapter 8: Optional Equipment” for option information, or contact your authorized Xerox reseller.

Although this guide is written for the casual user, it is necessary for you to have a basic knowledge of your applications and operating system in order to use the guide most effectively. Additional resources for Systems Administrators and users who need more detailed technical information are listed at the end of this chapter on page 1–7 under “Where To Go For More Information.”



---

**NOTE:** *Before using your printer, be sure you have performed all the steps outlined in the **Quick Installation Guide** packaged with your printer.*

---

## What Is In This Guide

---

Chapter 1: *Introduction* describes the type of information in this *User's Guide*, the conventions used for special information, and the resources available for additional information.

Chapter 2: *Introduction to Your C55 Printer* describes basic printer models and features, explores printer components, and provides a brief overview of printer drivers.

Chapter 3: *Print Media* describes how to load and print on different types of media, such as paper, transparencies, labels, and envelopes.

Chapter 4: *The Control Panel* describes how to select and navigate through the menus of the Control Panel.

Chapter 5: *Xerox Printer Driver Options* describes the C55 printer drivers (PCL 5C and Adobe PostScript) that you can use to achieve optimal printer performance.

Chapter 6: *Troubleshooting* explains how to solve minor problems that may occur. These problems include media jams and defects in the printed document. You will also find a chart of error messages in this chapter that includes suggested actions you can take to correct specific error situations.

Chapter 7: *Printer Maintenance* identifies the procedures to follow in order to correctly maintain your printer.

Chapter 8: *Optional Equipment* identifies items you can purchase in order to customize your printer for your specific needs. It also includes instructions for installing additional memory.

Chapter 9: *Network Printer Services* provides an overview of the CentreWare DP and CentreWare Internet Services printer services utilities.

Appendix A: *Safety Notes* provides important information about how to safely operate your printer.

Appendix B: *Special Notices* contains information about agency certifications.

Appendix C: *Printer Technical Specifications* lists the physical, electrical, and environmental requirements for the C55 printer.

The *Index* provides an easy reference to topics covered in the *User's Guide* and lists page numbers where these topics are explained.

## Conventions Used

---

This Guide uses the following writing and style conventions to emphasize specific types of information.

Buttons will appear in bold text. For example, **Enter** indicates a button that may be pressed. General screen selections will appear in bold text when you are given procedures for selecting them.

Control Panel menu selections appear in all caps and within < > symbols. For example, <CONTROL MENU> indicates a selection you can make from the Control Panel menu.

Titles of other information resources appear in bold italic, such as the *Technical Information Guide*.



---

**NOTE:** *Text which includes important information to remember is identified by the word “NOTE” and is located within lines (as in this example).*

---



**CAUTION:** Bold text preceded by an exclamation point and the word “CAUTION” identifies an action that should be taken only after you have considered the consequences. The consequences of the action are also identified.



**WARNING:** Bold text preceded by an exclamation point and the word “WARNING” alerts you to hazardous conditions or situations where you should proceed carefully in order to avoid personal injury or damage to the printer.

## Where To Go For More Information

---

In addition to this *User's Guide*, there are several other sources of information available to you. The following references are also packaged with your printer:

- The *Quick Installation Guide* provides installation information to help you with the initial setup of your printer.
- The *Quick Network Install Guide* provides specific information to help you connect your printer to a network.
- The *Technical Information Guide* contains detailed information for System Administrators. Topics covered include detailed information about: network setup on all supported network operating systems, Control Panel operation and Error Codes. It can be found on the CD packaged with your printer documentation.
- The *On-Line Help* screens provide additional information about printer driver features.
- The *Support Brochure* provides information about how to obtain further assistance.
- The *CentreWare User Guide* provides information on the CentreWare DP network print management software. It can be found on the CD packaged with your printer documentation.
- HTML help files for CentreWare Internet Services can also be found on the CD.





## CHAPTER 2



# Introduction to Your C55 Printer

---

- Printer Features
- Printer Components—External
- Printer Components—Internal

In this chapter, you will become familiar with the features of your printer and learn where to locate specific printer parts.

Before you use your printer, make sure that you perform all of the steps outlined in the *Quick Installation Guide* that came with your printer, and connect the necessary print cables.

The Xerox C55 color laser printer provides brilliant full color laser prints on ordinary paper. Recognizing that you may have special needs, Xerox offers several optional equipment items to better meet your requirements. These are explained in detail in Chapter 8, “Optional Equipment.”

Two of the more popular options are already included in model C55mp:

- Adobe PostScript Level II, including several special imaging features
- Ethernet Card, for quick direct connection to a network

Xerox, or your Xerox authorized reseller, may have provided the above three options, or even more options. First verify your exact equipment options before proceeding further. If you see features described in this section that are not available with the equipment you have, you can easily add them yourself. For more information, see Chapter 8.

## Printer Features

---

Your C55 printer has many special features that allow you to achieve the color printing results you need for your specific print job. Features vary slightly according to the C55 model you are using and the memory installed in your printer. This section will help you become familiar with your printer's features and capabilities.

### Print Speed

Print speeds for printing on standard (Letter/A4) media are as follows:

- Up to 3 pages per minute for full-color prints
- Up to 6 pages per minute in Fast Blue mode (See “Chapter 5: Printer Driver Color Options”)
- Up to 12 pages per minute for black and white prints on all paper sizes
- Up to 1.9 pages per minute for full-color transparencies
- Up to 6 pages per minute for black and white transparencies

## Resolution

The resolution of your printed image is determined by the number of printed dots per inch (dpi). The C55 printer provides the following resolutions:

- Color  
600 x 600 dpi—standard  
Contone—PostScript only
- Black  
600 x 600 dpi—standard  
Contone—PostScript only

## Resident Fonts

The following fonts are included with your printer:

- 35 Adobe Type 1 fonts in PostScript System
- 35 Intellifonts in all systems
- 10 TrueType fonts in all systems

## Connectivity

The C55 printer comes standard with a high speed mini-Centronix IEEE 1284 ECP compliant Bi-Directional parallel port.

- It supports the Win 95 Plug & Play standards

Optional Interfaces include:

- LocalTalk and Serial Port
- Ethernet 10MBPS with BNC and RJ-45 connectors (included with C55mp)
- Token Ring 4/16 MBPS with RJ-45 and Shielded DB9 connectors

Printing Protocols Enabled with Ethernet or Token Ring Cards:

- NetWare 2.x, 3.x, and 4.x with complete NDS native support (IPX/SPX)
- AppleTalk (EtherTalk/TokenTalk)
- SunOS, Solaris (TCP/IP)
- WFWG (DLC/LLC)
- Windows NTAS (DLC/LLC)
- Windows '95 (IPX/SPX)-Peer to Peer
- IBM LAN Server, Microsoft LAN Manager (DLC/LLC)
- Auto-protocol sensing switches port to correct protocol
- HTTP (CentreWare Internet Services)

## Color Matching Systems

The following color matching systems will be available for the C55 printer:

- Pantone Profiles
- Apple ColorSync 2.0
- Image Color Matching (ICM)



---

**NOTE:** *For more detailed information on printer specifications and connectivity, consult the **Technical Information Guide**.*

---

## Printer Driver Software

The printer driver is a piece of software that is loaded on your workstation. Use of the proper printer driver for your operating system and printer model is essential for getting the best in color printing. It is important for two reasons:

1. Printer drivers provide access to features unique to your printer. Although there are many print options and features that are a part of the software applications you use, your printer also contains many distinctive features of its own. For example, your C55 printer drivers enable you to use the Xerox Intelligent Color features that are available in your printer.
2. To print effectively, it is necessary for you to install the correct printer driver. You can use the PCL 5C printer driver with your C55. If you have the Adobe PostScript option (standard on the C55mp), you can also use the PostScript printer driver. The PostScript printer driver allows access to more of the exclusive and powerful Xerox printing features. For more information about available drivers and operating systems supported by your C55 printer, see the ***Technical Information Guide***.



---

**NOTE:** Application specific files that enable you to use your C55 printer with PageMaker, FreeHand, and QuarkXpress are included in the installation software.

---

## Printer Components—External

Use Figures 2–1 and 2–2 to identify the main exterior components of your C55 printer.

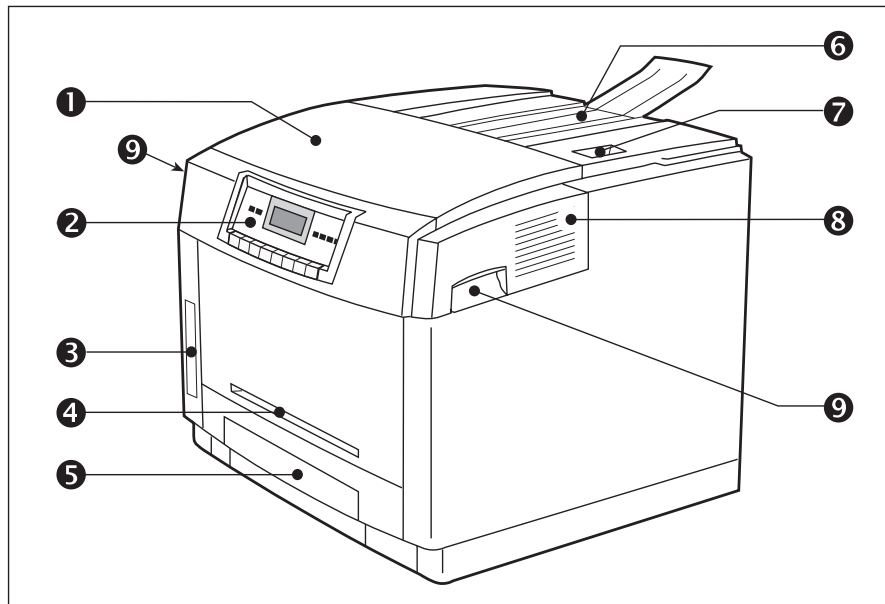
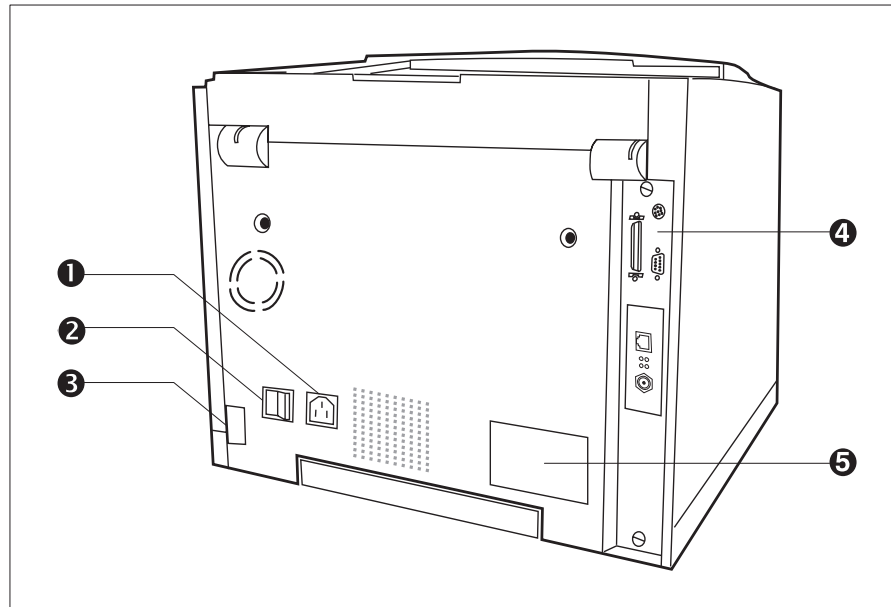


Figure 2–1: The C55 Printer, Front View

- |                           |                          |
|---------------------------|--------------------------|
| ❶ Fuser Cover             | ❹ Media Exit Area        |
| ❷ Control Panel           | ❺ Top Rear Cover Release |
| ❸ Media Server (optional) | ❻ Front Cover            |
| ❹ Manual Feed Slot        | ❼ Front Cover Release    |
| ❺ Tray 1                  |                          |

Optional Lower Feeder not shown. See “Chapter 8: Optional Equipment.”





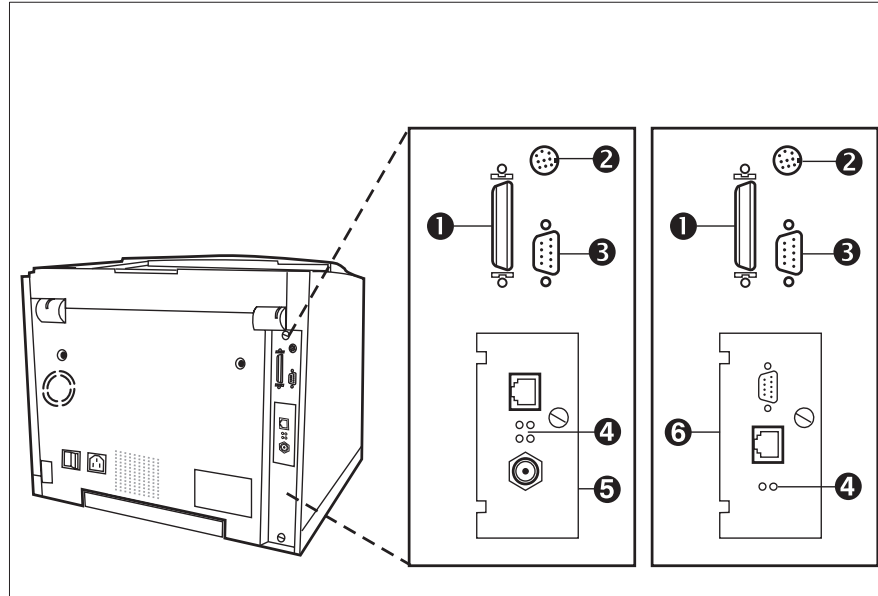
**Figure 2-2: The C55 Printer, Rear View**

- ❶ Power Cord Receptacle
- ❷ On/Off Switch
- ❸ Lower Feeder Electrical Connection
- ❹ Interface Connectors (see next page)
- ❺ Safety Certification and Voltage Information Label



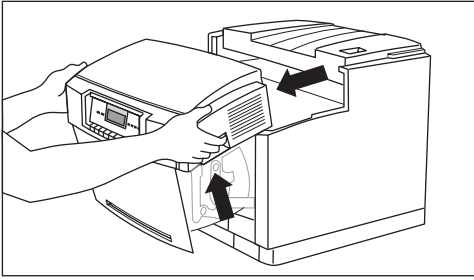
**NOTE:** Detailed information about Network Interface Connectivity can be found in the **Technical Information Guide**.

Your printer interface connectors are located on the back of the printer as shown in Figure 2-3 below. Your printer comes equipped with a standard mini-Centronics parallel connector. In addition, space is provided for an optional Serial/LocalTalk card and one Network Interface card (either Ethernet or Token Ring). Note: the Ethernet card comes standard with a C55mp.



**Figure 2-3: The Connection Interface Area**

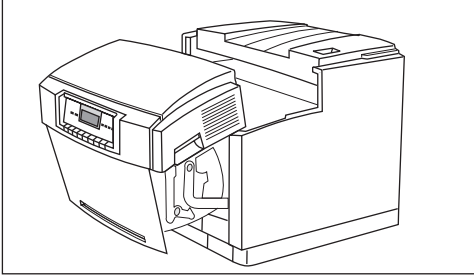
- |                          |                         |
|--------------------------|-------------------------|
| ① Parallel Port          | ④ Network Activity LEDs |
| ② LocalTalk Connector    | ⑤ Ethernet Connectors   |
| ③ RS232 Serial Connector | ⑥ Token Ring Connector  |

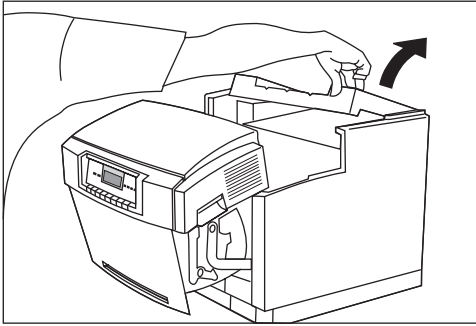


The C55 printer has three covers, which are identified in Figure 2-1. Use the following instructions to open each cover and gain access to the internal components of your printer.

### To Open the Front Cover:

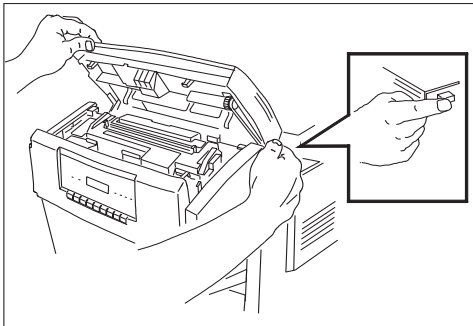
1. Simultaneously grasp the two latches, located on the front cover, and pull up to release them.
2. Gently pull the cover up and toward you until it rests in a lowered position.





### To Open the Top Rear Cover:

1. Press the release button, located on the Top Rear Cover.
2. Lift the cover up until it stands in an upright position.



### To Open the Fuser Cover:



**NOTE:** *The Front Cover must be opened before you can open the Fuser Cover.*

1. Press the Fuser Cover release button, located on the Front Cover.
2. Lift the Fuser Cover straight up and back until it rests in an upright position.

## Printer Components—Internal

Figure 2-4 shows how the C55 printer's internal components are arranged. Two important groups of internal components of your printer are the Consumables (replenishable substances used by the printer) and Maintenance Items (the parts that require replacement). See the insert to order these items.

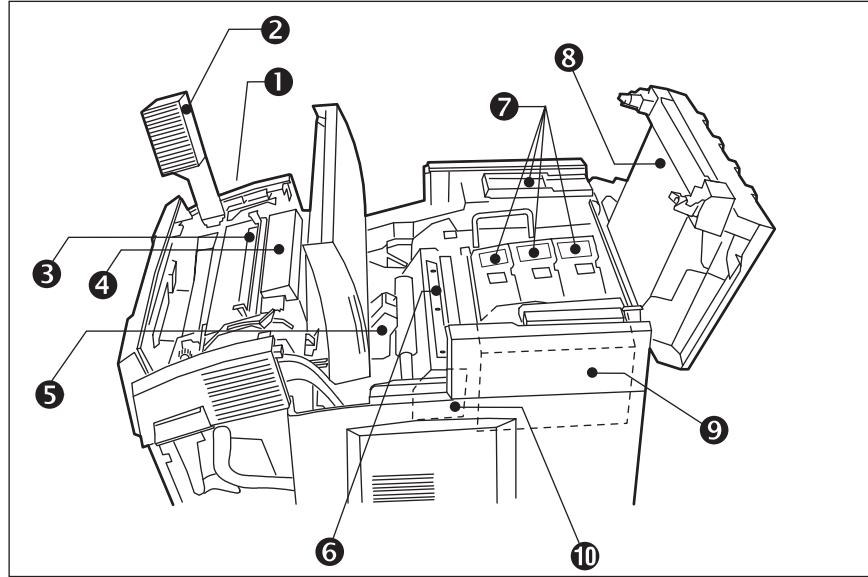


Figure 2-4: The C55 Printer, Internal View of Components

- |                        |                                  |
|------------------------|----------------------------------|
| ① Fuser Area           | ⑥ Print Drum                     |
| ② Ozone Filter         | ⑦ Black/Color Toner Refill Doors |
| ③ Fuser Cleaner Roller | ⑧ Serial Number Plate            |
| ④ Fuser Oil Bottle     | ⑨ Color Developer Unit           |
| ⑤ Toner Collector      | ⑩ Black Developer Unit           |





## CHAPTER 3

# Print Media

---

- Recommended Media
- Loading the Media Tray
- The Manual Feed Slot

This chapter explains recommendations for media and procedures for using the media trays and the Manual Feed Slot in your printer. In order to ensure reliable printer performance, please follow the media loading instructions in this chapter.

## Recommended Media

---

Your C55 color laser printer will produce brilliant color images on a wide variety of print media. Carefully choosing the media for your printer is important in achieving the very best images and in ensuring trouble-free operation. Selecting quality paper and transparencies is recommended for avoiding potential problems with heat-intensive printing. Xerox strongly recommends that you only use media and transparencies designed for use in color laser printers. Tell this to your suppliers.

The paper you use should be dust-free, and have cleanly cut edges. Don't use curled, wrinkled, or damp paper. Also note that smoother surface paper will produce sharper output resolution and better image detail. For the best results, DO NOT use recycled paper, extremely shiny coated paper, rough textured paper, or pre-printed forms. Pre-printed letterhead paper designed for use in laser printers or color copiers will perform well.

### **PAPER:**

16 - 24 lb. (60-90 gsm.) can be fed automatically via the universal media tray. Several types of papers are sold by Xerox resellers, or Xerox. Not all media is available in all locations, though. Some of the popular Xerox sold papers include Xerox 4024DP, Image Series LX, Xerox 60, Xerox 80, and Xerox Colortech 90.



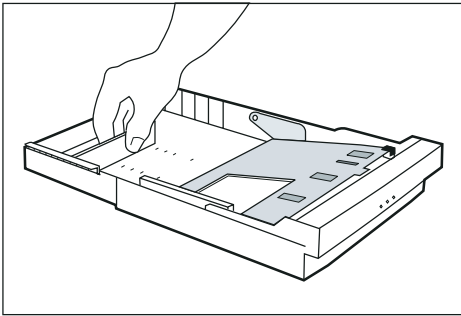
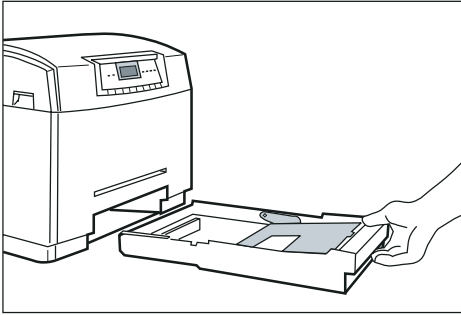
**TRANSPARENCIES:**

Your C55 color laser printer is ideal for creating bright, vivid color transparencies, for use with an overhead projector. Best results will be obtained by using Xerox/Rank Xerox transparencies. Xerox makes transparency material especially designed for the best images. These include 3R4446 for letter size images, and 3R96002 for A4 sized images. Other transparencies may be available in certain countries. Note that transparencies can be printed from either the Manual Feed Slot or the Universal Media Tray.

**LABELS AND ENVELOPES:**

Black and white images can easily be printed on laser-quality labels and envelopes from the Manual Feed Slot. **DO NOT** attempt to print in color, or via the Universal Tray. Best results will be obtained by carefully selecting media that is designed for use in laser printers. Xerox markets fully-tested labels and envelopes in most countries.

## Loading the Media Tray



### How to Load the Tray With Paper

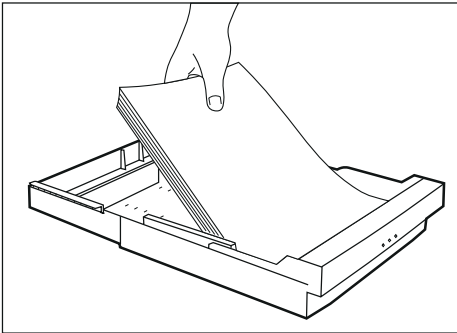
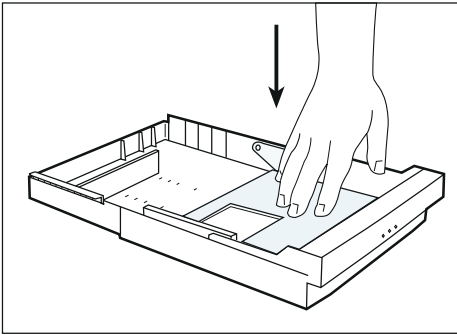
The universal paper tray can be used for standard paper weights of 16 - 24 lb. (60-90 gsm.) and any of the supported paper sizes:

- Letter (8.5x11 in.)
- A4 (210x297 mm)
- Legal (8.5x14 in.)
- Executive (7.25x10.5 in.)
- A5 (148x210 mm)
- Invoice (5.5x8.5 in.)
- SP. Folio (216x315 mm)
- Folio (8.5x13 in.)
- 8x10
- B5 (176x250 mm)

The printer automatically detects the standard sizes (letter, A4, legal and executive) but you must designate the size in the Control Panel if another size paper is used (see “Chapter 4: Designate Custom Paper Size”). To load the tray with paper:

1. Grasp the handle of the tray, and remove it from the printer.
2. Adjust the side and back edge guides to accommodate the paper to be loaded. To adjust a guide, carefully pull the guide straight up, place it into the holes indicated for the size desired, and then gently press the guide securely into the holes.

(Continued on next page.)



3. Press down on the metal pressure plate until it is flat against the bottom of the tray.
4. Place the paper into the tray so that the side to be printed is facing up and the edge of the paper nearest to the tray handle is inserted under the tabs. Do not fill the tray above the maximum fill line indicated.
5. Reinsert the tray into the printer.



**WARNING:** The C55 printer is not designed to print double-sided (duplex) prints. Attempting to produce double-sided prints will damage your printer.

## How to Load the Tray With Letterhead Paper

Load letterhead paper in the same way that you load plain paper (with the printed side up). (See “How to Load the Tray With Paper,” on page 3-3.) The typical orientation of letterhead paper is shown in Figure 3-1.

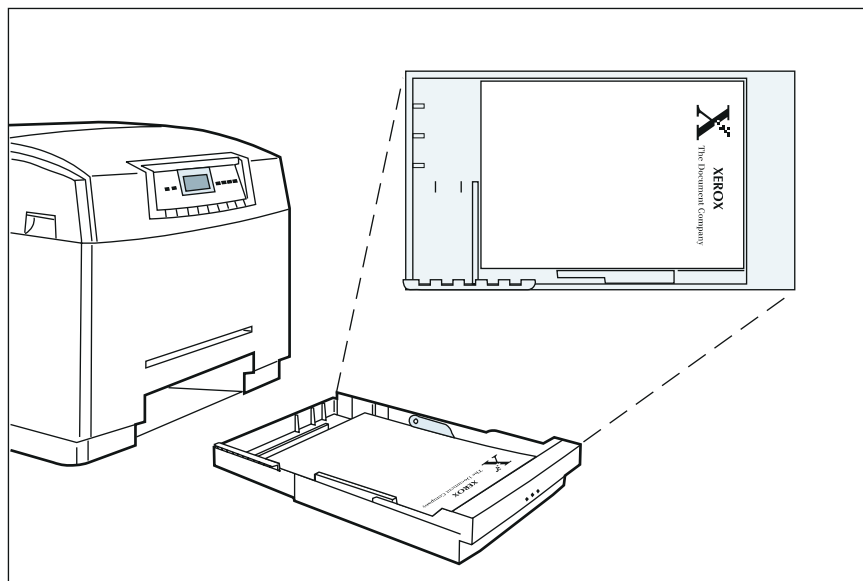


Figure 3-1: Letterhead Paper Loaded In The Media Tray

## How to Load the Tray With Transparencies

Load transparencies in the same way that you load paper. (See “How to Load the Tray With Paper,” on page 3–3.) Use recommended transparencies for optimum performance. Do not fill the tray with more than 75 sheets.



---

**NOTE:** *Your C55 printer automatically detects transparencies at the time of printing and adjusts the print settings to optimize transparency quality.*

---

### TRANSPARENCY TRAY

If your printer has two trays, you can designate one of the trays as the transparency tray. The printer will automatically feed from the designated transparency tray if the media is selected as “Transparency” in the driver.

You can designate a tray as the “Transparency Tray” through either the printer’s Control Panel or the CentreWare DP software. See page 4–16 in Chapter 4: *The Control Panel* for more information about how to designate a tray as a Transparency Tray by using the Control Panel. To designate a tray by using CentreWare DP, refer to the *Technical Information Guide*.

## The Manual Feed Slot

---

The Manual Feed Slot, located on the front of the printer just above the media tray, allows you to print on:

- a single sheet of special stock up to 24 lb. (90 gsm.) or letterhead paper
- a sheet of paper that is a non-standard size
- a transparency
- a sheet of labels (in black only)
- an envelope (in black only)
- a cover for a document set on a different stock.



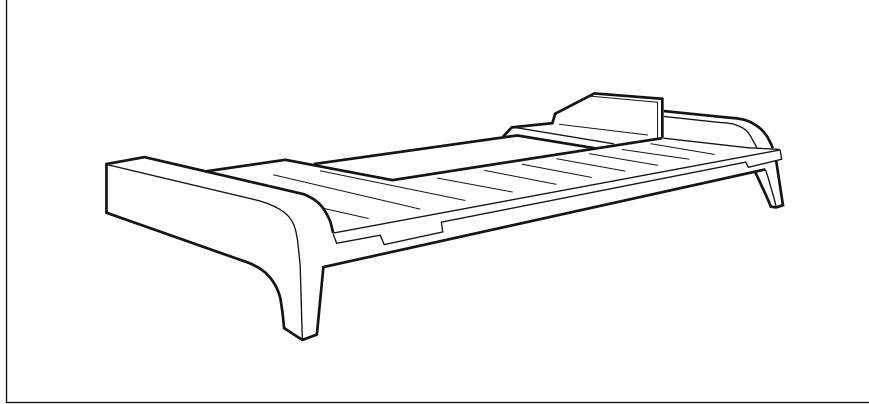
---

**NOTE:** *In order to use the Manual Feed Slot, you must attach the Manual Feed Tray and feed the media one sheet at a time.*

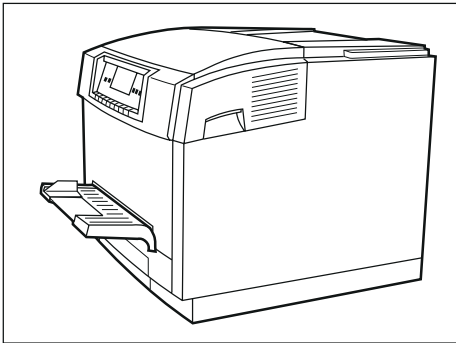
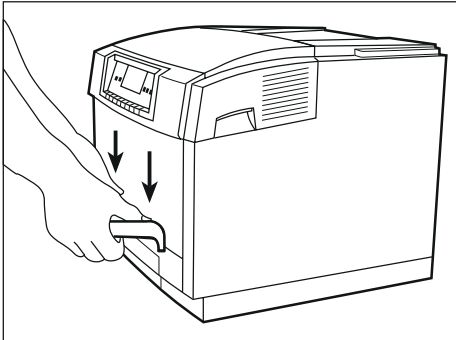
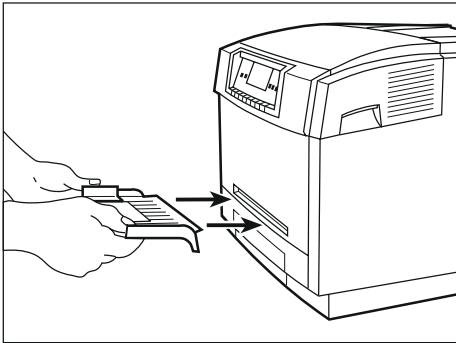
---

## The Manual Feed Tray

Your C55 printer comes with a removable Manual Feed Tray. This tray attaches to the front of the printer and guides individual sheets or envelopes as they enter the Manual Feed Slot. The Manual Feed Tray aligns each sheet correctly and helps to ensure that it enters the printer smoothly.



**Figure 3–2: The Manual Feed Tray**

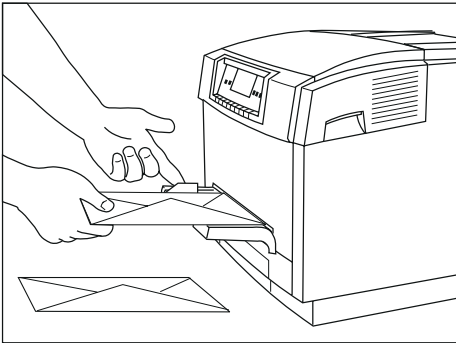
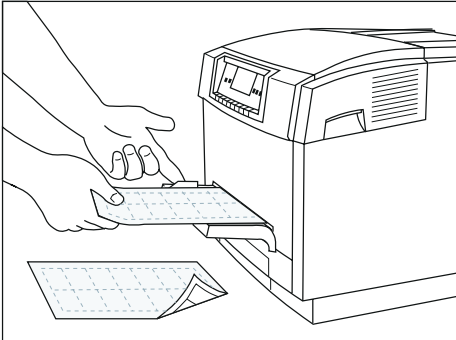
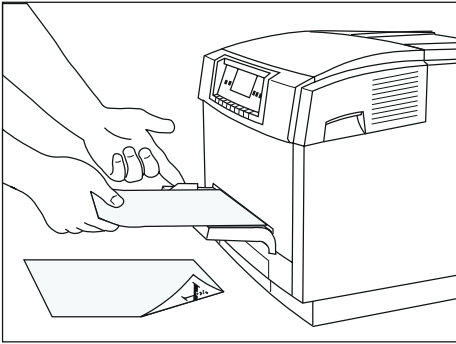


## How to Attach the Manual Feed Tray

To attach the Manual Feed Tray to the front of the printer:

1. Orient the tray so that the edge with the two small tabs and the support arms is facing the printer.
2. Align the tabs on the edge of the tray with the indentations just inside of the Manual Feed Slot, and insert the edge of the tray into the slot.
3. Press gently on the top of the tray above the tabs until the tabs fit securely into the indentations.
4. Rest the support arms against the front of the printer.





## How to Use the Manual Feed Slot

Media inserted in the Manual Feed Slot overrides the Paper Source selection in your driver. You can use this to print a page (or cover) in a document set on a different media than the remainder of the document. Simply insert the media before the page is printed.

To print normally from the Manual Feed slot:

In your printer driver:

1. Select **Manual Feed** as the Paper Source in the C55 printer driver.
2. For transparencies, envelopes, or labels, select the correct option in the Media Type in the C55 printer driver.

At your printer:

3. When prompted by the Control Panel message, place the media print-side down on the Manual Feed Tray.



**CAUTION:** Before you load a sheet of labels into the Manual Feed Slot, make sure that the edges of the labels are not loose or sticking up. Loose edges can get stuck when the sheet passes through the printer and can cause jams that are difficult to clear.

(Continued on next page.)

4. Place the media against the right edge of the Manual Feed Tray. Push the side edge guide against the left side of the media. The media should be flat against the tray without any wrinkles or bent edges.
5. Push the media into the Manual Feed Slot. The media will be pulled into the printer.



**WARNING: The C55 printer is not designed to print double-sided (duplex) prints. Attempting to produce double-sided prints will damage your printer.**



## CHAPTER 4

# The Control Panel

---

- Control Panel Components
- Control Panel Use
- Control Panel Menus
- Using the Optional Media Server

The C55 printer's Control Panel allows you to enter commands and receive printer status information directly at the printer. In this chapter, you will find out how to use the Control Panel and how to print from the optional Media Server.

## Control Panel Components

---

The Control Panel consists of several buttons, indicator lights, and a two-line Message Display Window. You can use the Control Panel buttons to select functions and move through menus. The lights indicate that certain actions are taking place. The Message Display Window displays messages, directions, and your Control Panel Menu selections. Figure 4-1 shows each button and indicator light on the Control Panel.

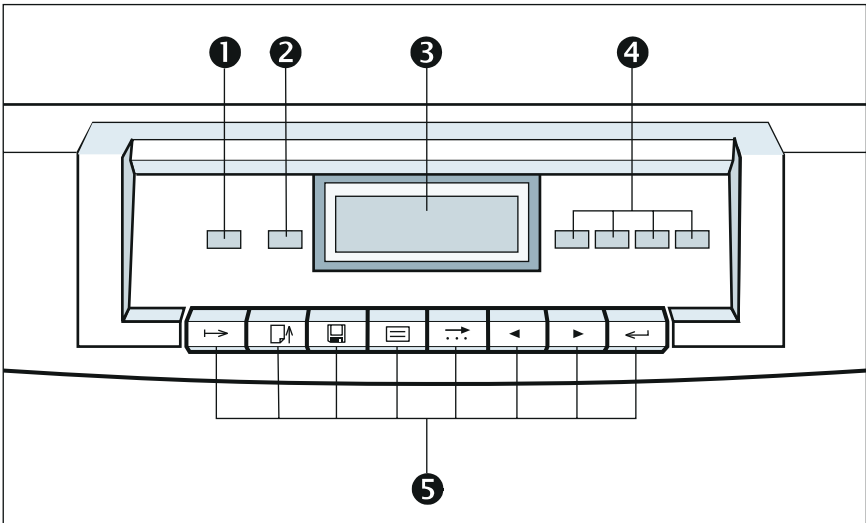


Figure 4-1: The C55 Control Panel

- ❶ On Line light
- ❷ Form Feed light
- ❸ Message Display Window
- ❹ Four Color Toner indicator lights
- ❺ Control Panel Buttons

## Control Panel Indicator Lights

Refer to the following table for an explanation of the purpose of each light.





**Table 4-1: Control Panel Indicator Lights**

INDICATOR LIGHTS	PURPOSE
On Line	Steady light indicates the printer is idle and on line. Flashing light indicates the printer is processing data. No light indicates the printer is off line.
Form Feed	Steady light indicates that a PCL 5C document is in memory but that the printer has not yet received an end-of-paper character. See Table 4-2.
Toner Indicators	The steady light indicates which color toner is currently being applied during the printing process. The light will flash if the individual color toner is empty.

## Control Panel Buttons





Control Panel Buttons allow navigation through the menu system and execute menu commands that are displayed.

**Table 4–2: Control Panel Buttons**

BUTTON	PRESS TO
On Line 	Take the printer off line and put it back on line again. The message display window displays <PAUSED> if in the middle of a job and taken off line or <OFF LINE> if the printer is idle.
Form Feed 	Print the page for PCL jobs that do not have a Form Feed command.  Release jobs that were sent using the Hold Job feature. See Chapter 5.
Media Server 	Gain access to the Media Server menus. If the printer is busy, an <ERROR> message displays, and the printer returns to on line. See “Using the Optional Media Server,” below.
Menu 	Start at or return to the top of the menu structure.  Go to the top of the menu structure when the printer is “Off-line” or “Paused.”

(Continued on next page.)

**Table 4-2: Control Panel Buttons (continued)**

BUTTON	PRESS TO
Select 	Move to the next field or digit when entering an IP Address or network information.
Previous 	Move to the previous menu item in the current level of a menu.  Decreases the value of the alphanumeric entries.
Next 	Move to the next menu item in the current level of a menu.  Increases the value of the alphanumeric entries.
Enter 	Choose the menu item displayed between the < > symbols in the Message Display Window.



## Control Panel Use

---

This section provides general information on Control Panel navigation, an explanation of Control Panel menus, and specific procedures for using some common Control Panel functions.

### Menu System Navigation

You begin all Control Panel tasks by taking the printer off line and selecting a Top Menu item. Follow the steps below for a line-by-line view of any one of the Top Menus in the Control Panel's Message Display Window.

1. Press the **On Line** button, located immediately below the Message Display Window. The <ON LINE> message is cleared, and <OFF LINE> is displayed.



---

**NOTE:** *The printer must be off line to access Control Panel menus.*

---

2. Press the **Menu** button, located immediately below the Message Display Window, to start at the top of the menu structure. The <OFF LINE> message is cleared, and the Top Menu <CONTROL MENU> is displayed.

The menu selection displayed between the <> symbols is the active menu. The first Top Menu topic displayed is the Control Menu.

3. Press the **Previous** or **Next** buttons, located immediately below the Message Display Window, to scroll through the ten Top Menus. (Press the **Next** button to display the next menu item. Press the **Previous** button to display the previously displayed menu item.)

4. Press the **Enter** button to select a menu. The first sub-level menu option is displayed in the Message Display Window.
5. Use the **Previous** and **Next** buttons to scroll through the sub-level menu options.
6. Press the **Enter** button to select a menu option or execute the menu command that is displayed.



---

**NOTE:** *The Enter button executes the displayed menu command and will take you to the next sub-level menu option.*

---

Press the **Menu** button at any time to return to the beginning of the Top Menu.

OR

Press **Enter** when <EXIT THIS MENU> is displayed, in order to exit the menu.

8. Press the **On Line** button to end menu navigation and put the printer back on line again. Any settings you have changed since the printer went off line will be saved when the printer goes on line.

## Control Panel Menus

---

There are ten Top Menu selections available on the Control Panel. While most Top Menu selections pertain to more complex tasks, there are a few Top Menu features that you may need to use regularly. The three Top Menus most commonly accessed are Control Menu, Imaging and Media Server if installed. The following section describes the ten Top Menus and includes a list of their functions and sub-menus in Table 4-3.



---

**NOTE:** *More detailed information about the Control Panel Menus can be found in the **Technical Information Guide**.*

---

### The Top Menus

Table 4-3 describes Top Menu selections in the order that they will appear. Sub-menu selections are listed in the same manner. There may be further, more specific, menu selections under a sub-menu that do not appear on this table. (To print a complete list of the Control Panel menus and sub-menus, follow the procedure on page 4-14 for printing the Control Panel Menu.)

**Table 4-3: The Top Menus**

TOP MENU	FUNCTION	SUB-MENU SELECTIONS
Control Menu	Cancel a job. Reset the printer.	Cancel job Reset printer
Maintenance	Check the status of Maintenance Items.	Color Developer/ Black Developer Print Drum Fuser Module Show Pg Count
Media Menu	Set and customize the defaults for media trays.	Tray Auto Tray Switch Transparency Custom Size
Print	Print the configuration for print settings and resident fonts.	Startup Settings PS Fonts PCL Fonts Menu Demos

**Table 4-3: The Top Menus (continued)**

TOP MENU	FUNCTION	SUB-MENU SELECTIONS
Multinational	Change the language used for messages and imbedded documents.	English French Italian German Spanish Portuguese
Communications	Enable and configure the data ports. Establish the network configuration.	Parallel Serial LocalTalk Network Setup
Setup	View or change advanced printer settings.	Color Adjust Configuration Timing Support Info Memory PCL Emulation Factory Reset

**Table 4-3: The Top Menus (continued)**

TOP MENU	FUNCTION	SUB-MENU SELECTIONS
Service	Print test patterns, view software levels and error logs.	Test patterns Error Logs Adjustments Compression
Imaging	Change defaults for Imaging and Color Mode Options.	Edge Smoothing Color Mode Overprint Halftone Type Enh Alignment
Media Server	Control printing from a floppy disk.	Select File Setup

## Specific Examples of Control Panel Use

This section provides step-by-step procedures for several commonly performed Control Panel tasks. Examples in this section include instructions about how to:

- Print the Control Panel Menu
- Check the Color Developer status
- Designate a transparency tray
- Modify common printer settings

**PRINT THE CONTROL PANEL MENU**

To assist you in using the Control Panel, you may want to print a map of the complete menu system. Follow the steps below to print the menus for your reference.

1. Press the **On Line** button located on the Control Panel. The <ON LINE> message is cleared, and <OFF LINE> is displayed.
2. Press the **Menu** button, located immediately below the Message Display Window. The <OFF LINE> message is cleared, and the Top Menu <CONTROL MENU> is displayed.
3. Scroll through the Top Menus, using the **Next** button until <PRINT> is displayed.
4. Press the **Enter** button. The <PRINT> message is cleared, and the first sub-level menu is displayed.
5. Scroll through the sub-level menu options, using the **Previous** and **Next** buttons, until <MENU> is displayed.
6. Press the **Enter** button to print the menu.
7. Press the **On Line** button to put the printer back on line.



### CHECK THE COLOR DEVELOPER STATUS

You may also check the status of maintenance items directly at the printer. Follow the steps below when you want to view the status of the color developer.

1. Press the **On Line** button located on the Control Panel. The <ON LINE> message is cleared, and <OFF LINE> is displayed.
2. Press the **Menu** button, located immediately below the Message Display Window. The <OFF LINE> message is cleared, and the Top Menu <CONTROL MENU> is displayed.
3. Scroll through the Top Menus, using the **Previous** and **Next** buttons until <MAINTENANCE> is displayed.
4. Press the **Enter** button to display the secondary level of menu options.
5. Scroll through the sub-level menu options, using the **Previous** and **Next** buttons until <COLOR DEV CART> is displayed.
6. Press the **Enter** button to select the <COLOR DEV CART> menu option. A third level of menu selections is displayed that shows the percentage of remaining Color Developer.
7. Press the **On Line** button to put the printer back on line.

**DESIGNATE A TRANSPARENCY TRAY**

If the optional Lower Feeder (Tray 2) is installed on your printer, you can use the following procedures to designate Tray 1 or 2 as the transparency tray. See “Chapter 3: Print Media.”

1. Press the **On Line** button located on the Control Panel. The <ON LINE> message is cleared, and <OFF LINE> is displayed.
2. Press the **Menu** button, located immediately below the Message Display Window. The <OFF LINE> message is cleared, and the Top Menu <CONTROL MENU> is displayed.
3. Scroll through the Top Menus, using the **Previous** and **Next** buttons until <MEDIA MENU> is displayed.
4. Press the **Enter** button when <MEDIA MENU> is displayed.
5. Scroll through the sub-level menu options, using the **Previous** and **Next** buttons until <TRANSPARENCY> is displayed.
6. Press **Enter** when <TRANSPARENCY> is displayed.
7. Scroll to display either <TRAY 1> or <TRAY 2>.
8. Press the **Enter** button when the tray you want to designate as a transparency tray is displayed.
9. Press the **On Line** button to put the printer back on line again.

## DESIGNATE CUSTOM PAPER SIZE

To use the media tray for paper sizes other than letter, A4 or legal, you must set the paper size in the Control Panel. Follow the steps below to set the tray to one of the supported sizes. (Sizes not listed in the Control Panel menu can only be printed through the Manual Feed tray. See “Chapter 3: Print Media.”)

1. Press the **On Line** button located on the Control Panel. The <ON LINE> message is cleared, and <OFF LINE> is displayed.
2. Press the **Menu** button, located immediately below the Message Display Window. The <OFF LINE> message is cleared, and the Top Menu <CONTROL MENU> is displayed.
3. Scroll through the Top Menus, using the **Previous** and **Next** buttons until <MEDIA MENU> is displayed.
4. Press the **Enter** button when <MEDIA MENU> is displayed.
5. Scroll through the sub-level menu options, using the **Previous** and **Next** buttons until <CUSTOM SIZE> is displayed.
6. Press **Enter** when <CUSTOM SIZE> is displayed.
7. Scroll to display the desired paper size.
8. Press the **Enter** button when the paper size you want to designate is displayed.
9. Press the **On Line** button to put the printer back on line again.

## Using the Optional Media Server

---

The Media Server, an optional disk drive that you can order and install, enables you to print PostScript and PCL 5C files directly at the printer from a standard High Density, 3.5-inch, MS DOS formatted disk, with a 1.4 MB maximum capacity. Any C55 printer can easily be upgraded with a Media Server Option.

The optional Media Server adds several advantages to your C55 printer:

- A convenient way to print on special media (such as transparencies) in a networked environment
- A way to print if your network or computer is disabled
- The assurance of the confidentiality of your documents when printing in a networked environment
- The convenience of sharing your printer with anyone with walk-up service for printing files from a disk
- A way to elevate your print job to priority status (The Media Server print requests supersede the network print queue.)

## Print to File

There may be times when you do not want to send your document directly to the printer. You may want to print your document using the Media Server or store your document as a print file (with the specific feature settings) to a hard drive. There are three ways to do this—through your printer driver, your application software, or your operating system. For information about how to Print to File using your application software or your operating system, consult your specific software or operating system manuals.

When you Print to File using your C55 printer driver, the printer driver creates a file which contains the contents of your document and the feature settings you have selected. If you Print to File after making selections in the C55 color features, you must print the document on a C55 printer in order for those features to be implemented in your document. This file will be saved as either a PostScript or PCL 5C file depending upon the driver that is being used.

Choose Print to File after all other print options have been selected. You can save the file onto a disk so that it can be transported to a C55 printer to be printed using the Media Server, or you can save the file to any available hard drive to be stored for later use. (This feature is not available in all drivers.) Your file must fit on one floppy disk to use the Media Server.



---

**NOTE:** *If you are saving the file as a PostScript file, make sure you have a C55mp printer or that your printer has the optional PostScript Upgrade Kit installed.*

---

## How to Print From the Media Server

You can print your file with the default settings or customize your own print settings. If you have saved the file with specific application settings, print using the Media Server Menu defaults. If you wish to add information not previously saved in the file, use the Media Server Menu options to customize file settings such as print quantity.

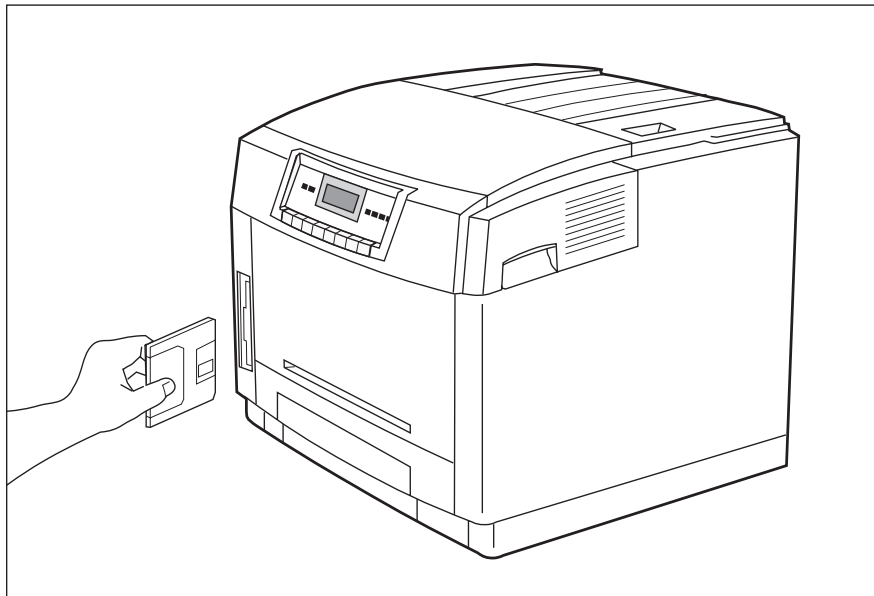


Figure 4-2: Using the Media Server

To print from the Media Server:

1. Create a PostScript or PCL 5C printer file. (You cannot print an application file at the Media Server. You must use the Print to File utility.) Save the printer file you created on a standard High Density, 3.5-inch, MS DOS formatted disk.
2. Insert the disk into the Media Server's disk drive as shown in Figure 4-2.
3. Press **Media Server** on the Control Panel. The display window will display <SELECT FILE>.
4. Press **Enter**. (You can press **Next** to scroll through different files saved on your disk or select <ALL FILES> to print all files.)
5. Press **Enter** when the file shown on the display window is the file you want to print.

To print your file using customized settings:

1. Insert the disk into the Media Server's disk drive as shown in Figure 4-2.
2. Press the **Media Server** button. The Message Display Window will display <SELECT FILE>. Press **Next** to display <SETUP MENU>. Press **Enter**.
3. Press **Next** to move through the sub-level menu selections:  
<MODE>  
<QUANTITY>  
<TRAY>
4. Press **Enter** when the sub-level menu displayed is the one you want to make choices within.
5. Press **Previous** and **Next** in order to display choices for the sub-level menu you selected.
6. Press **Enter** when the choice you want to apply to your file is displayed between the < > symbols.
7. Press **Next** until <EXIT THIS MENU> is displayed, and press **Enter**.
8. Press **Next** until <SELECT FILE> is displayed, and Press **Enter**.
9. Use the **Previous** and **Next** buttons to scroll until the file you want to apply your custom settings to is displayed and press **Enter** to print your file with the custom settings applied.



---

**NOTE:** *Any application-specific settings saved to your file will override Media Server Menu options.*

---





## CHAPTER 5

# Special C55 Printer Driver Options

---

- PostScript vs. PCL 5C Printer Driver Feature Comparison
- PCL 5C Printer Driver Features
- PostScript Printer Driver Features
- ImageFix (Windows 95 PostScript)

Your C55 printer offers many special features that are designed to produce the highest quality color and black & white prints while giving you the flexibility you need to print a variety of documents. These features are accessed through the C55 printer drivers and are described in this chapter.

The way these features are accessed depends on both the C55 printer driver that you are using and your operating system. Not all the features described in this chapter are available in all operating systems. Use the descriptions in this chapter as a general guide to help you take advantage of the features available.

The information in this chapter is organized by printer driver type (by the features specific to the PCL 5C printer drivers and the features specific to the Adobe PostScript printer drivers). Not all features are available for all drivers. Refer to the section that matches the printer driver you use. The C55 supports only the PCL 5C printer drivers (unless you have the optional Adobe PostScript installed), and the C55mp supports both Adobe PostScript or PCL 5C printer drivers. Select Help in the C55 printer drivers for more information.



---

**NOTE:** *The C55 can be upgraded with the Adobe PostScript Kit and additional memory to be PostScript enabled. See “Chapter 8: Optional Equipment” for ordering information.*

---

## PostScript vs. PCL 5C Printer Driver Feature Comparison

---

**Table 5-1: C55 Printer PCL 5C vs. PostScript**

Feature	PCL 5C	PostScript
Xerox Intelligent Color 3.0	Yes	Yes
Expert Color Control	Yes (PCL 5C Implementation)	Yes
Save Toner	Yes	Yes
Edge Smoothing	Yes	Yes
Enhanced Alignment	Yes	Yes
Contone	No	Yes
Fax Friendly Black	No	Yes
ImageFix	No	Yes (Windows 95 only)
Fast Blue	No	Yes
Black Overprint	No	Yes
Collation	No	Yes

## PCL 5C Printer Driver Features

---

Your C55 PCL 5C printer driver includes several unique features provided by Xerox. These unique features are provided to aid you in producing high quality color as well as black and white prints. For information on other features not described here, select Help in your driver.

### **Color Settings (Xerox Features tab)**

The options available for Color Settings are:

#### **INTELLIGENT COLOR**

Xerox Intelligent Color 3.0 automatically optimizes the appearance of your printed documents and simplifies the task of creating color documents by modifying the printer behavior so that different object types will be rendered in an optimal fashion.

#### **VIVID COLOR**

Vivid Color produces bright, solid colors and should be used for documents with graphics that include charts and graphs.

#### **PHOTO COLOR**

Photo Color is the best color setting to use for photographs or bitmap images.

**GRAYSCALE**

Grayscale changes all of the colors of your document into black, white, and shades of gray. Use Grayscale when you do not need the distinction of color yet you want to maintain the detail of your document. A document printed with Grayscale prints faster than the same document printed in color.

**SAVE TONER**

Save Toner reduces the toner consumption needed to print in color. The hues of each color do not change, but the colors are less saturated. Use Save Toner to decrease the overall toner consumption, produce lower cost prints, and provide draft copies of your document.

**UNADJUSTED**

Unadjusted uses your application settings. It allows the application to control processing and halftones used when the document is printed. Use this print mode when your application or operating system has a color matching system (such as Pantone or Image Color Matching.)



---

**NOTE:** *You must use Unadjusted print mode in conjunction with your color matching system to obtain the colors you expect.*

---

**Edge Smoothing (Xerox Features tab)**

Edge Smoothing reduces the rough or jagged edges of black text and line art.

**Enhanced Alignment (Xerox Features tab)**

Your C55 color printer includes a new feature to deliver improved image quality. If your documents contain black lines, or black text placed directly next to colored areas, you may want to select Enhanced Alignment. When used, your printer will automatically adjust itself to improve the black image alignment next to colored areas. Note that this feature is most valuable when black and colored areas directly touch.

**Tray Switching (Paper tab)**

Select Tray Switching to have the printer automatically switch to a second tray (if so equipped) to continue your print job, when the first tray runs out of paper.

**Hold Job (Paper tab)**

Select Hold Job to delay printing for a set period of time enabling you to get to the printer to load special media, or to print out confidential material. A message will appear on your screen indicating that you have a limited period of time to proceed to the printer to press the Form Feed button on the printer's Control Panel in order to initiate the print activity. If you do not press the Form Feed button within the preset time-out, the job will be deleted from the printer's memory. The Hold Job time-out is set from the Control Panel or through the CentreWare DP software. See the *Technical Information Guide* for more details.

**Document Halftones (Xerox Features tab)**

Halftone is the process by which images are printed as a pattern of many small dots. The size and density of the dots produce shades of light and dark in the image when it is printed. Also, different combinations of the four primary toner colors produce an extensive range of possible colors. You can choose from two Halftone Settings—Quad Dot and Smooth Screen.

**QUAD DOT**

Quad Dot is a patented Xerox technology which produces clear, well-defined pictures and graphics. It provides smoother fine lines with less visible grain.

**SMOOTH SCREEN**

Smooth Screen halftones distribute the halftone dots in a more random pattern in order to produce a smoother effect for color sweeps.

## Expert Color Control

Expert Color Control enables you to fine-tune the colors on your printed document.



---

**NOTE:** *The Expert Color Control results will be much different between PostScript and PCL 5C due to the differences in the printer description languages.*

---

### COLOR ADJUSTMENT

In Color Adjustment, there are two slider bars you can use to make adjustments for lightness and saturation. As you slide each bar, the numerical value for that bar is indicated in the box to the right of the bar.

#### Lightness

Lightness relates to the brightness of the color produced. A higher setting lightens the colors on the document overall, giving it a faded look, while a lower setting darkens the colors overall.

#### Saturation

Saturation affects the intensity of color or the amount of chromatic color in proportion to its lightness. For example, this is the aspect that distinguishes a pale red from a bright red. A lower setting provides less color saturation (is less colorful), while a higher setting provides a higher color saturation (is more colorful) on your document overall.



## COLOR BALANCE

The scroll bars in the Color Balance allow you to adjust the range between contrasting colors. This feature enables you to adjust the amount of Red, Green, and Blue in the colors of your document. As you slide the bar to the right (the higher numerical values), the amount of color increases in the document overall. For example, if you slide the Red bar to the right, the amount of red increases in your document overall. As you slide the bar, the value for that color is indicated in the box to the right of the bar.



---

**NOTE:** *If you make more than one change to the color adjustment or color balance, there will be a cumulative effect on the color you are trying to achieve. If you are not satisfied with the results of the adjustments you have made, select the **Default** button to return the adjustments to their default settings.*

---

## Save Settings

To duplicate at a later date all of the selections you made for your document in Color Settings, Document Halftone, Expert Color Control and Advanced Features, select the **Save Settings** button. When you select the **Save Settings** button, a dialog box will display. Type a file name and select the location where you want to save the file. Save the file and close the dialog box. If you need to print this document at a later date using previously selected and saved printer settings, choose the **Restore Settings** button. The settings you made when you saved the settings for the document will be applied to the document when it is printed.

Any changes you make after you have saved the settings to a file (using Save Settings) can be applied during printing, but they will not be saved to your settings file. If you want to keep the new settings, you need to select **Save Settings** again.

## Restore Settings

To return to previously saved settings, use the **Restore Settings** button. Choose the settings file that includes the settings you want to restore. The selections in Color Settings, Document Halftone, Expert Color Control and Advanced Features will be restored to the settings stored in the file.

## PostScript Printer Driver Features

---

Your C55 PostScript printer driver includes several unique features provided by Xerox. These unique features are provided to aid you in producing high quality color as well as black and white prints. For information on other features not described here, select Help in your driver.

### Output Modes

#### COLLATION

Collated printing delivers documents as ordered sets. Select this option when you want to print two or more sequenced sets of a multi-page job.

For example:      Collation selected - 1,2,3; 1,2,3; 1,2,3  
                          Collation not selected - 1,1,1; 2,2,2; 3,3,3




---

**Note:** Always select collation in the C55 printer driver. To avoid unexpected results, turn off collation in your application. Do NOT select collation in both the application and the Xerox printer driver, as duplication of sets may occur.

---

Collation may work differently based on the available printer system. The amount of memory on the printer—whether or not the optional hard disk is available—and the complexity of your job can affect your collated output. There may be cases where a job will be collated in sections. For example, three sets of a six page job could print as 1,2,3,4; 1,2,3,4; 1,2,3,4; 5,6; 5,6; 5,6.

#### TRAY SWITCHING

Select Tray Switching to have the printer automatically switch to a second tray (if so equipped) to continue your print job, when the first tray runs out of paper.

**HOLD JOB**

Select Hold Job to delay printing for a set period of time, enabling you to get to the printer to load special media, or to print out confidential material. A message will appear on your screen indicating that you have a limited period of time to proceed to the printer to press the Form Feed button on the printer's Control Panel in order to initiate the print activity. If you do not press the Form Feed button within the preset time-out, the job will be deleted from the printer's memory. The Hold Job time-out is set from the Control Panel or through the CentreWare DP software. See the **Technical Information Guide** for more details.

## Color Settings

The options available for Color Settings are:

### **INTELLIGENT COLOR**

Xerox Intelligent Color 3.0 automatically optimizes the appearance of your printed documents and simplifies the task of creating color documents by modifying the printer behavior so that different object types will be rendered in an optimal fashion.

### **VIVID COLOR**

Vivid Color produces bright, solid colors and should be used for documents with graphics that include charts and graphs.

### **PHOTO MODE (IMAGEFIX IN WINDOWS 95 DRIVER)**

Photo Mode is the best color setting to use for photographs or images. (Windows 95 users, see ImageFix later in this chapter.)

### **GRAYSCALE**

Grayscale changes all of the colors of your document into black, white, and shades of gray. Use Grayscale when you do not need the distinction of color yet you want to maintain the detail of your document. A document printed with Grayscale prints faster than the same document printed in color.

**FAX FRIENDLY BLACK (POSTSCRIPT ONLY)**

Fax Friendly Black changes your color document to patterns of black and white. The different colors are rendered as different, distinguishable patterns in black and white. For example, a pie chart that contains wedges of different solid colors will be printed with a different pattern replacing each color so that the distinction between the pieces is maintained. Color text is also rendered as a pattern, but the character is outlined. Anything that is black in your document remains black and is not rendered as a pattern.

Use Fax Friendly Black to print a color document in a black and white mode so that it can be used as a fax original or for black and white copying.

**FAST BLUE (POSTSCRIPT ONLY)**

Fast Blue prints a color document only in shades of blue (cyan) and black. All color text and images in the document are rendered in shades of blue while the text and images that were originally black remain black. The shades of blue maintain the distinction among parts of your document which were originally in different colors.

Use Fast Blue to print color documents at twice the speed of full color, while retaining more color information than when using Grayscale.

**SAVE TONER**

Save Toner reduces the toner consumption needed to print in color. The hues of each color do not change, but the colors are less saturated. Use Save Toner to decrease the overall toner consumption, produce lower cost prints, and provide draft copies of your document.

**UNADJUSTED**

Unadjusted uses your application settings. It allows the application to control processing and halftones used when the document is printed. Use this print mode when your application or operating system has a color matching system (such as Pantone or Image Color Matching.)



---

**NOTE:** *You must use Unadjusted print mode in conjunction with your color matching system to obtain the colors you expect.*

---

## Document Halftone

Halftone is the process by which images are printed as a pattern of many small dots. The size and density of the dots produce shades of light and dark in the image when it is printed. Also, the many different combinations of the four primary toner colors produce an extensive range of possible colors. You can choose from three Halftone Settings – Quad Dot, Smooth Screen, and Contone.

### QUAD DOT

Quad Dot is a patented Xerox technology which produces clear, well-defined pictures and graphics. It provides smoother fine lines with less visible grain.

### SMOOTH SCREEN

Smooth Screen halftones distribute the halftone dots in a more random pattern in order to produce a smoother effect for color sweeps. It works well when there is a variation of light to dark color such as a color sweep.



---

**NOTE:** *The Quad Dot and Smooth Screen halftone screens have been designed for optimum print quality and are identical in PostScript and PCL 5C.*

---

### CONTONE (POSTSCRIPT ONLY)

Contone produces a smooth gradation of tones (between light and dark). You can use this feature to produce finer halftones and more grayscales.



## Expert Color Control

Expert Color Control enables you to fine-tune the colors on your printed document.

### COLOR ADJUSTMENT

In Color Adjustment, there are three slider bars you can use to make adjustments for lightness, contrast, and saturation. As you slide each bar, the numerical value for that bar is indicated in the box to the right of the bar.

#### Lightness

Lightness relates to the brightness of the color produced. A higher setting lightens the colors on the document overall, giving it a faded look, while a lower setting darkens the colors overall.

#### Contrast

Contrast adjusts the difference between light and dark color. A lower setting gives a slight variation from light to dark, and a higher setting gives a greater variation from light to dark on your document overall.

#### Saturation

Saturation affects the intensity of color or the amount of chromatic color in proportion to its lightness. For example, this is the aspect that distinguishes a pale red from a bright red. A lower setting provides less color saturation (is less colorful), while a higher setting provides a higher color saturation (is more colorful) on your document overall.

### COLOR BALANCE

The scroll bars in the Color Balance allow you to adjust the range between contrasting colors. The three bars indicate a range between Red and Cyan, Green and Magenta, and Blue and Yellow. As you slide the bar, the saturation of the color increases in the direction you slide the bar, and the saturation of the color that the bar moves away from decreases. For example, when you slide the bar toward red, the amount of red increases on your document overall while simultaneously the amount of cyan decreases. As you slide the bar, the numerical value for that bar is indicated in the box to the right of the bar.



---

**NOTE:** *If you make more than one change to the color adjustment or color balance, there will be a cumulative effect on the color you are trying to achieve. If you are not satisfied with the results of the adjustments you have made, select the **Default** button to return the adjustments to their default settings.*

---

## Save Settings

To duplicate at a later date all of the selections you made for your document in Color Settings, Document Halftone, Expert Color Control and Advanced Features, select the **Save Settings** button. When you select the **Save Settings** button, a dialog box will display. Type a file name and select the location where you want to save the file. Save the file and close the dialog box. If you need to print this document at a later date using previously selected and saved printer settings, choose the **Restore Settings** button. The settings you made when you saved the settings for the document will be applied to the document when it is printed.

Any changes you make after you have saved the settings to a file (using Save Settings) can be applied during printing, but they will not be saved to your settings file. If you want to keep the new settings, you need to select **Save Settings** again.

## Restore Settings

To return to previously saved settings, use the **Restore Settings** button. Choose the settings file that includes the settings you want to restore. The selections in Color Settings, Document Halftone, Expert Color Control and Advanced Features will be restored to the settings stored in the file.

## Advanced Features

The Advanced features enable you to further fine-tune the images in your document.

### **BLACK OVERPRINT (POSTSCRIPT ONLY)**

Select this feature to print black text and graphic objects over color backgrounds in order to overcome possible misregistration (thin white outlines around the black edges).

### **USE APPLICATION COLOR SPACE (POSTSCRIPT ONLY)**

Select this feature to use the color space specifications provided by the application as opposed to the color space specifications provided by the printer. The color space specifications provided by the printer are optimized to give the best printed results.

However, finer control of the color space through the application is sometimes desired. If your application cannot support this feature, the printer default color space is used.

### **DISABLE CMYK COVERAGE LIMIT (POSTSCRIPT ONLY)**

Select this feature to remove the 250% toner coverage limit. The CMYK Coverage Limit should only be disabled when you use a color management system such as Pantone.



**WARNING:** Do not disable the CMYK Coverage Limit except when necessary. This may result in the use of an excessive amount of toner in an attempt to produce deep or dark colors which may not fuse to the paper. Continuous use of excessive toner may cause permanent damage to the fuser.

**EDGE SMOOTHING**

Select this feature to reduce the rough or jagged edges of black text and line art.

**ENHANCED ALIGNMENT**

Your C55 color printer includes a new feature to deliver improved image quality. If your documents contain black lines, or black text placed directly next to colored areas, you may want to select Enhanced Alignment. When used, your printer will automatically adjust itself to improve the black image alignment next to colored areas. Note that this feature is most valuable when black and colored areas directly touch.

## **ImageFix (Windows 95 PostScript only)**

---

ImageFix replaces the Color Setting, Photo Mode, in the Windows 95 PostScript driver.

ImageFix analyzes and enhances the contrast and sharpness of RGB bitmapped images (24-bit color) and 8-bit grayscale images. The amount of visual enhancement from ImageFix is dependent on the quality of the original image. Poor quality will show significant improvement, while high-quality images will show less. This feature will not work on CMYK images or applications that use their own internal drivers, such as Adobe PageMaker and CorelDRAW.





## CHAPTER 6

# Troubleshooting

---

- Before You Begin Troubleshooting
- Error Messages
- How to Clear A Media Jam
- Print Defects
- Additional Sources of Troubleshooting Assistance

This chapter provides information about preventing problems, and specific instructions for clearing media jams. It also contains tables showing detailed error messages and examples of print defects with suggested corrective actions.

## Before You Begin Troubleshooting

---

If it becomes necessary for you to take corrective actions, note the following safety tips and then begin your troubleshooting by checking for possible hardware, software, and printer maintenance issues.



**CAUTION:** Do not use tools or sharp objects to clear jams since this may damage the printer. Do not touch the surface of the Print Drum or the Transfer Drum. Touching these surfaces may damage them.



**WARNING:** Avoid contact with the Fuser area, which may be hot.

Also, be sure to observe the safety guidelines and recommendations provided in Appendix A: *Safety Notes*.

If your printer is not operating properly, make sure that the following hardware and software issues have been considered.

### Hardware

- Is the printer plugged in?
- Is the printer switched on?



## Software

- Is the correct printer driver installed and selected for your printer configuration? (For example, do not use the Adobe PostScript driver with a non-PostScript enabled printer).

## Printer Maintenance

An improperly seated tray or an open cover can delay your print job. You can avoid these problems by regularly taking the following precautions.

- Insert media trays properly and securely.
- Keep covers securely closed.

## Consumables

Empty toner dispenser, low oil, or full waste collector will delay your print job.

- Keep consumables and maintenance items in supply.
- Add or replace when prompted by printer.



---

**NOTE:** *Specific instructions for replacing each Consumable and Maintenance Item are included with the individual replacement packages.*

---

## Error Messages

---

The C55 printer's error code and message system allows you to quickly and easily find and correct minor problems that may occur with your printer. Error messages alert you to trouble by displaying a letter and number code on the Control Panel's Message Display Window. If you receive an error message, refer to Table 6-1: Error Messages, which follows.

When referring to this table, note the following:

- Instructions for adding toner and replacing components are included in the individual replacement packages.
- Error messages that begin with a "W" advise that certain Maintenance Items are near depletion. You do not need to replace these items until a message that begins with "J" is displayed, but you might want to make sure that you have replacement items available.



---

**NOTE:** *If you encounter an error message that is not listed, consult the **Technical Information Guide** or if you are unable to clear the error with the suggested procedures listed in Table 6-1, call your Xerox Service Provider for assistance.*

---

**Table 6-1: Error Messages**

Error Code and Message Displayed	Explanation	Action to Take
C1-CHECK TRAY 1	Tray 1 is not properly inserted into the printer.	Remove and reinsert Tray 1 into the printer.
C2-CHECK TRAY 2	Tray 2 is not properly inserted into the printer.	Remove and reinsert Tray 2 into the printer.
E1-TRAY 1 JAM OPEN PRINTER	A jam has occurred in Tray 1.	Remove Tray 1. Remove any jammed material in the path. Reinsert Tray 1. Refer to page 6-17.
E2-TRAY 2 JAM OPEN PRINTER	A jam has occurred in Tray 2.	Remove Tray 2. Remove any jammed material in the path. Reinsert Tray 2. Refer to page 6-17.
E3-MANUAL FEED JAM OPEN PRINTER	A jam has occurred in the Manual Feed Slot area.	Remove the Manual Feed Tray. Remove jammed material from the Manual Feed Slot area. Reinsert the tray. Refer to page 6-17.

**Table 6-1: Error Messages (continued)**

Error Code and Message Displayed	Explanation	Action to Take
E4-INPUT JAM OPEN PRINTER	A jam has occurred in the input area.	Open the Front Cover and remove any jammed material in the input area. Close the cover. Refer to page 6-15.
E5-FUSER JAM OPEN PRINTER	A jam has occurred in the Fuser area.	Open the Front Cover and the Fuser Cover. Release fuser rollers. Remove any jammed material in the Fuser area. Close the covers. Refer to page 6-13.
E6-DRUM JAM OPEN PRINTER	A jam has occurred in the Transfer Drum area.	Open the Front Cover and remove any jammed material that is in the Transfer Drum area or is adhered to the Transfer Drum. Close the cover. Refer to page 6-15.
E7-PRINT DRUM JAM OPEN PRINTER	A jam has occurred in the Print Drum area.	Open the Front Cover and remove any jammed material in the Print Drum area. Close the cover. Refer to page 6-15.

**Table 6-1: Error Messages (continued)**

Error Code and Message Displayed	Explanation	Action to Take
E8-OUTPUT JAM OPEN PRINTER	A jam has occurred in the output area.	Open the Front Cover and the Fuser Cover. Remove any jammed material in the output area. Close the covers.  Refer to page 6-13.
E9-PLEASE CLOSE PRINTER	One or more of the printer covers is open.	Check all printer covers to make sure that they are closed properly.
F1-DISK ERROR	The disk is not readable, not properly formatted, or not inserted properly into the Media Server.	Remove and reinsert the disk.  Try another standard High Density, 3.5 inch, MS DOS formatted disk.
F2-DISK I/O ERR	An error has occurred while reading the disk in the Media Server.	Remove and reinsert the disk. Select the file again.  Try another standard High Density, 3.5 inch, MS DOS formatted disk.
F3-ACTION FAILED	A miscellaneous Media Server failure has occurred.	Remove and reinsert the disk. Select the file again.  Try another standard High Density, 3.5 inch, MS DOS formatted disk.

**Table 6-1: Error Messages (continued)**

Error Code and Message Displayed	Explanation	Actions to Take
H1-HARD DISK ERROR	The printer is unable to find the hard disk.	Switch the power off and then switch it on again.
H2-HARD DISK CONTROLLER ERROR		Switch the power off and then switch it on again.
H3-HARD DISK IS FULL	The printer hard disk is full.	Remove fonts or resources from the hard disk using CentreWare DP.
JA-REPLACE OIL KIT	The printer is out of fuser oil.	Open the Front Cover and the Fuser Cover. Install a new Fuser Oil Kit. Close the covers.
J1-ADD YELLOW TONER	The Yellow Toner level is low.	Open the Top Rear Cover and refill the Yellow Toner. Close the cover. *
J2-ADD MAGENTA TONER	The Magenta Toner level is low.	Open the Top Rear Cover and refill the Magenta Toner. Close the cover. *

\* If recently refilled and the message remains, toner may be blocking the opening. Tap the toner hopper lightly.

**Table 6-1: Error Messages (continued)**

Error Code and Message Displayed	Explanation	Action to Take
J3-ADD CYAN TONER	The Cyan Toner level is low.	Open the Top Rear Cover and refill the Cyan Toner. Close the cover.*
J4-ADD BLACK TONER	The Black Toner level is low.	Open the Top Rear Cover and refill the Black Toner. Close the cover.*
J5-REPLACE COLOR DEV. CARTRIDGE	The Color Developer has been depleted.	Replace the Color Developer Cartridge with a new unit.
J6-REPLACE BLACK DEV. CARTRIDGE	The Black Developer has been depleted.	Replace the Black Developer Cartridge with a new unit.
J7-REPLACE TONER COLLECTOR	The Toner Collector is full.	Replace the Toner Collector with a new unit.
J8-REPLACE PRINT DRUM	The Print Drum has reached its end of life.	Replace the Print Drum with a new unit.
J9-REPLACE FUSER MODULE	The Fuser has reached its end of life.	Replace the Fuser with a new unit.

\* If recently refilled and the message remains, toner may be blocking the opening. Tap the toner hopper lightly.

**Table 6-1: Error Messages (continued)**

Error Code and Message Displayed	Explanation	Action to Take
T0-POWER OFF/ON OR RESEAT FUSER	A Fuser Thermistor error has occurred.	Switch the power off and then switch it on again.
T1-POWER OFF/ON OR RESEAT FUSER	The temperature of the Fuser is lower than it should be.	If the problem persists, open the Front Cover and the Fuser Cover. Remove and reinstall the Fuser. Close the covers. Switch the power off and then switch it on again.
T2-POWER OFF/ON OR RESEAT FUSER	The temperature of the Fuser is higher than it should be.	
W1-COLOR DEV MOD NEAR END OF USE	The Color Developer is within 10% of its end of life being depleted.	No action is required. The message remains until the appropriate item is changed, or the "J#- "Replace" message is displayed.
W2-BLACK DEV MOD NEAR END OF USE	The Black Developer is within 10% of its end of life.	
W3-PRINT DRUM NEAR END OF USE	The Print Drum is within 10% of its end of life.	
W4-FUSER MODULE NEAR END OF USE	The Fuser is within 10% of its end of life.	
W5-OIL KIT NEAR END OF USE	The Fuser Oil Kit is within 10% of being depleted.	



## How to Clear A Media Jam

---

This section describes the media jam areas and gives basic instructions for clearing jams in each of these areas. Use these instructions to safely remove jammed media from your printer. The printer is designed to automatically shut down when a jam occurs, but will resume your print job at the point at which it was interrupted after the jam has been cleared.

You can greatly reduce the incidence of media jams by following these simple guidelines.

- Use media that is in good condition (not torn, wrinkled, or moist).
- Use recommended types, amounts, sizes, and weights of media. (Refer to “Chapter 3: Print Media.”)
- Load all media properly, and make sure that it is properly oriented for printing. (You can also try turning the media over if jams occur.)
- Select the correct Media Type in your printer driver.



---

**NOTE:** *A jammed transparency may not be easily visible; use the media jam diagrams and information that follow to help you locate and remove transparency jams.*

---

## Media Jam Areas

Figure 6-1 illustrates the four areas where a media jam might occur.

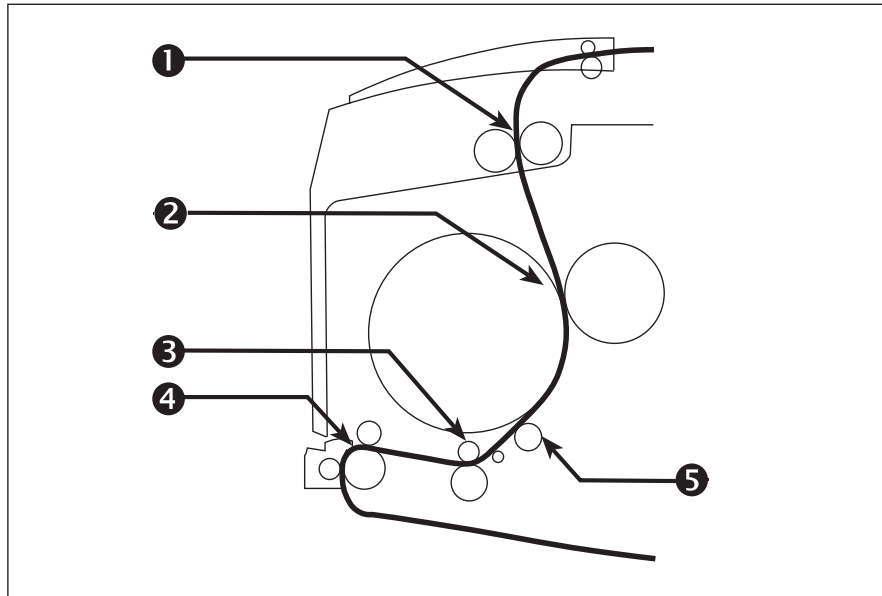


Figure 6-1: Media Path

- ❶ Fuser/Output Area
- ❷ Transfer Drum/Print Drum Area
- ❸ Input/Transfer Drum Area
- ❹ Tray and Manual Feed Slot Area
- ❺ Grounding Roller



**WARNING:** Exposure to prolonged periods of direct light may damage the Print Drum. Close the printer covers promptly after you have cleared a jam.

## Fuser/Output Area Jam

(Error Codes E5, E8)

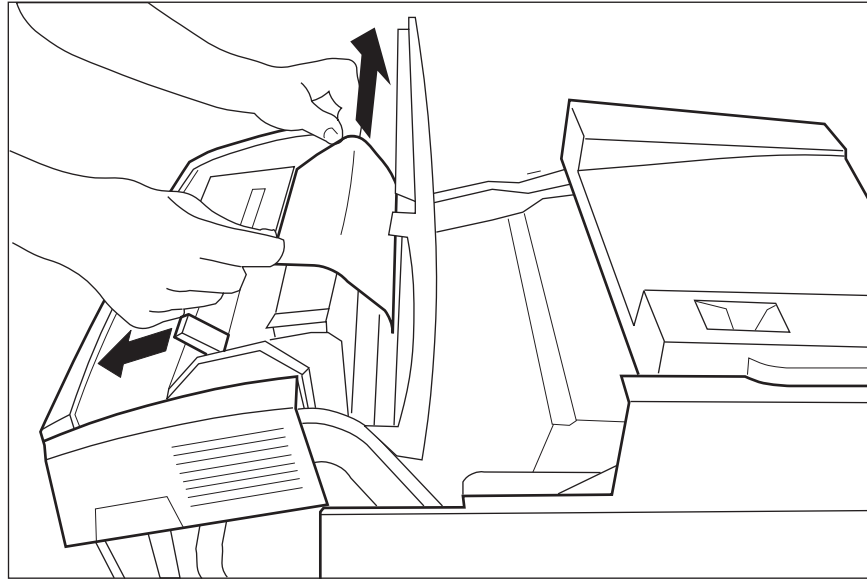


Figure 6-2: Fuser/Output/Print Drum Area Jam

1. Open the Front Cover. (See page 2-10.)
2. Open the Fuser Cover. (See page 2-11.)
3. Release Roller by rotating Release Lever.
4. Locate the lodged material by looking inside the Fuser area.

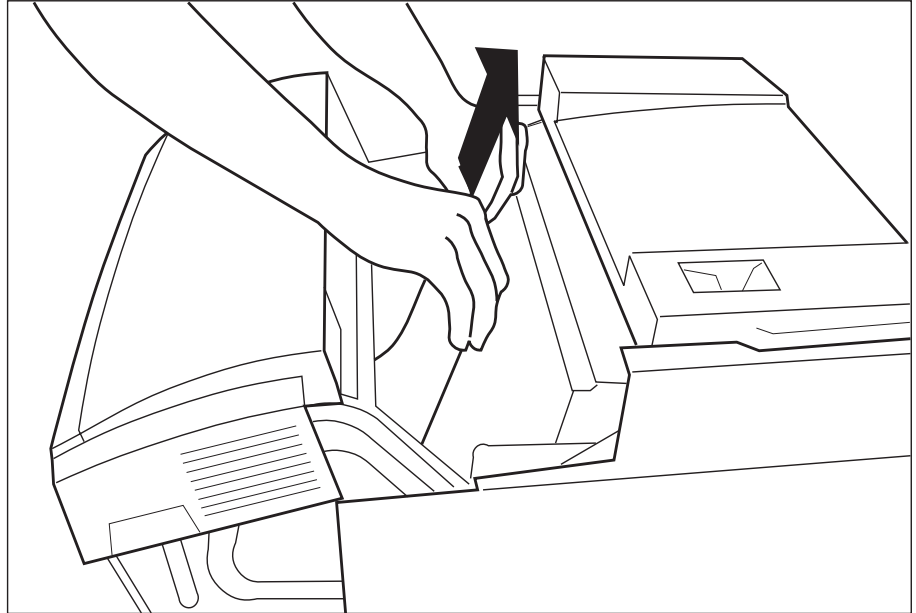


**WARNING:** Exercise caution as some internal printer surfaces are hot.

(Continued on next page.)

5. Reach into the Fuser area, and gently grasp the exposed corners of the jammed material.
6. Pull gently up and toward you until the material is completely dislodged.
7. Close Roller Release.
8. Close the Fuser Cover and the Front Cover.

## Input/Transfer Drum/Print Drum Area Jam (Error Codes E4, E6, E7)



**Figure 6-3: Input/Transfer Drum/Print Drum Area Jam**

1. Open the Front Cover.
2. Locate the lodged material by looking inside the Input/Transfer Drum area.
3. Reach into the Input/Transfer Drum area, and gently grasp the exposed corners of the jammed material.

(Continued on next page.)

4. Pull gently up and toward you until the material is completely dislodged.
5. If the material has adhered to the Transfer Drum, peel it away from the drum surface.
6. Close the Front Cover.

## Tray/Manual Feed Slot Jam

(Error Codes E1, E2, E3)

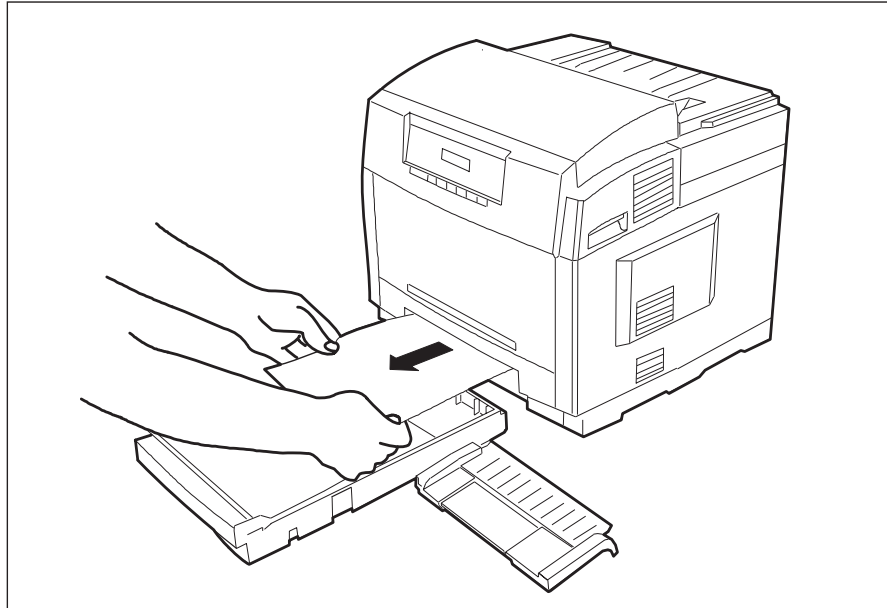


Figure 6-4: Tray/Manual Feed Slot Jam

1. Remove Tray 1, Tray 2, or the Manual Feed Tray (as indicated by the error code) from the printer.
2. Grasp the exposed corners of the jammed material gently.
3. Pull the material slowly toward you until it is completely dislodged.
4. Reinsert the paper tray or the Manual Feed Tray.

## Print Defects

---

Some common print defects, their causes, and potential remedies are described in Table 6-2. If you are unable to correct a print defect after you have followed the recommendations in Table 6-2, refer to the *Technical Information Guide* for additional help.


To reduce the incidence of print defects:

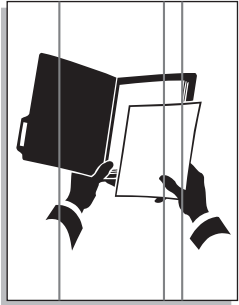
- Maintain a stable environment for the printer. (Refer to Appendix C: *Printer Technical Specifications* for environmental specifications.)
- Use the media recommended for this printer. (Refer to Chapter 3: *Print Media*.)
- Align the media with the paper edge guides in the paper tray.
- Protect the Print Drum from prolonged exposure to direct light.

Also observe the procedures for cleaning the printer, and adjusting the Color Balance that are outlined in Chapter 7: *Printer Maintenance*.

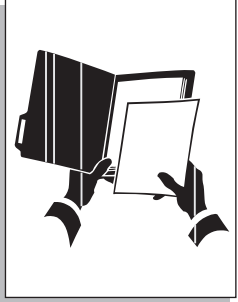


Table 6-2: Print Defects and Potential Remedies

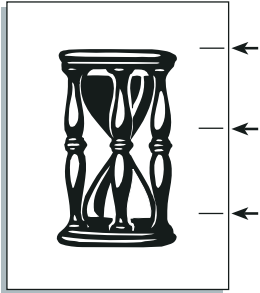
Print Defect	Common Causes	Potential Remedies
<p><b>Background Smudges</b>—Unwanted black and/or colored or shaded areas that appear on the page</p> 	<p>The printer is exposed to direct sunlight.</p> <p>The printer is exposed to excessive temperature and/or humidity.</p> <p>The Print Drum Charger is dirty</p> <p>The Print Drum needs to be replaced.</p> <p>The Black/Color Developer Cartridge needs to be replaced.</p>	<p>Move the printer to a location out of the sunlight.</p> <p>Place the printer in a less severe temperature and humidity condition.</p> <p>Clean the Print Drum Charger (see page 7-8).</p> <p>Replace the Print Drum.</p> <p>Replace the appropriate Developer Cartridge.</p>

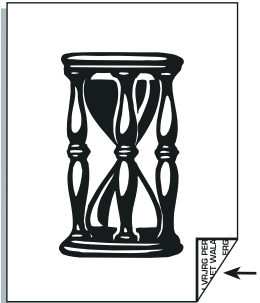
Print Defect	Common Causes	Potential Remedies
<p><b>Dark Vertical Lines</b>—Black or colored vertical lines that streak the page</p> 	<p>The Print Drum is scratched or damaged.</p> <p>Dry ink (toner) is on the Fuser rollers.</p> <p>Fuser needs to be replaced.</p>	<p>Remove and inspect the Print Drum. Replace it if any scratch or damage is visible.</p> <p>Install a new Fuser Cleaner Roller, included in the Fuser Oil Kit.</p> <p>Replace the Fuser.</p>

**Table 6-2: Print Defects and Potential Remedies (continued)**

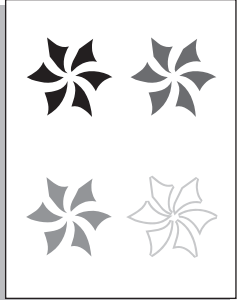
Print Defect	Common Causes	Potential Remedies
<p data-bbox="443 243 722 331"><b>Light, Vertical Lines</b>— Light areas (without color) that streak the page</p> 	<p data-bbox="748 243 992 300">The Print Drum is scratched or damaged.</p> <p data-bbox="748 394 1036 451">The Print Drum Charger is dirty.</p>	<p data-bbox="1062 243 1331 359">Remove and inspect the Print Drum. Replace it if any scratch or damage is visible.</p> <p data-bbox="1062 394 1317 451">Clean the Print Drum Charger (see page 7-7).</p>


**Table 6-2: Print Defects and Potential Remedies (continued)**

Print Defect	Common Causes	Potential Remedies
<p><b>Repeating Defects</b>—Marks that recur uniformly:</p> <ol style="list-style-type: none"> <li>Once every page</li> <li>Every 3.5 inches (89mm)</li> <li>Every 2.5 inches (64mm)</li> </ol> 	<ol style="list-style-type: none"> <li>The Print Drum is scratched or damaged.</li> <li>- Toner on the Fuser Rollers. - There is not enough oil on the Fuser rollers. - The Fuser cleaner is improperly installed.</li> <li>There is toner on the Grounding Roller.</li> </ol>	<ol style="list-style-type: none"> <li>Remove and inspect the Print Drum. Replace it if a scratch or damage is visible.</li> <li>- Clean the Fuser rollers. Run a blank sheet of paper through the printer to clean up any residual toner. - Replace the Fuser Oil Bottle. - Reinstall the Fuser cleaner assembly.</li> <li>Clean the Grounding Roller (see page 7-9).</li> </ol>

Print Defect	Common Causes	Potential Remedies
<p><b>Back-Side Contamination</b>—Toner that has been deposited on the non-imaged side of the prints</p> 	<p>Toner on the Fuser Rollers.</p> <p>There is not enough oil on the Fuser rollers.</p> <p>The Fuser cleaner is improperly installed.</p> <p>There is dirt in the paper path.</p>	<p>Clean the Fuser rollers. Run a blank sheet of paper through the printer to clean up any residual toner.</p> <p>Replace the Fuser Oil Bottle.</p> <p>Reinstall the Fuser cleaner assembly.</p> <p>Clean the paper path. See “Chapter 7: Printer Maintenance.”</p>

**Table 6-2: Print Defects and Potential Remedies (continued)**

Print Defect	Common Causes	Potential Remedies
<p><b>Missing Color</b>— One or more colors that are missing from the print</p> 	<p>The Developer for the missing color needs replacement.</p>	<p>Replace the appropriate Developer.</p>

Print Defect	Common Causes	Potential Remedies
<p><b>Light Color</b>— The density of one color is light on the print</p> 	<p>The Developer for the missing color needs replacement.</p>	<p>Replace the appropriate Developer.</p>

**Table 6-2: Print Defects and Potential Remedies (continued)**

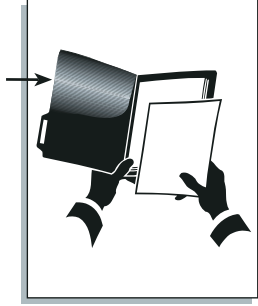

Print Defect	Common Causes	Potential Remedies
<p><b>Washed-out Areas</b>— Faded color areas that appear randomly on the page</p>  <p>The illustration shows a person's hands in black gloves. The left hand holds a black printer cartridge, and the right hand holds a white sheet of paper. A black arrow points from the cartridge towards the paper. On the paper, there is a rectangular area that is faded or washed out. The entire scene is enclosed in a rectangular frame.</p>	<p>Incorrect or damaged media has been used.</p> <p>If one color, the Developer needs replacement.</p> <p>If all colors, the Print Drum needs replacement.</p>	<p>Check the condition and appropriateness of the media being used.</p> <p>Replace the Developer Cartridge.</p> <p>Inspect the Print Drum for defects, and replace it if the defect is visible.</p>

Table 6-2: Print Defects and Potential Remedies (continued)

Print Defect	Common Causes	Potential Remedies
<p><b>Color Misregistration</b>—Color that has shifted outside of the designated area or has been superimposed over another color area</p> 	<p>The printer is not level.</p> <p>The Print Drum is improperly installed.</p>	<p>Level the printer.</p> <p>Reinstall the Print Drum.</p> <p>Switch the printer off and then on again.</p> <p>You may also try setting Black Overprint or Enhanced Alignment in the printer driver.</p>

## Additional Sources of Troubleshooting Assistance

---

If you encounter an error message, problem, or print defect that you are unable to correct by using your *User's Guide* or the *On-Line Help* system, you may need to contact your System Administrator or refer to the *Technical Information Guide*. For more complicated problems, contact your Xerox reseller or Xerox Support for assistance.



## C H A P T E R   7

# Printer Maintenance

---

- Regular Printer Maintenance
- Density and Color Balance Adjustment Procedure
- Cleaning Procedures

This chapter describes the maintenance needs of your printer, explains how often these services are recommended, and gives instructions about how to perform general maintenance on your printer.

## Regular Printer Maintenance

---

Your C55 printer is designed to need very little ongoing maintenance other than the replacement of maintenance items as they reach end of use. It is recommended that maintenance items are replaced when the end of use warnings appear on the control panel to avoid untimely image quality problems. However, it is always good practice to periodically clean any loose toner or foreign matter in your printer. See “Cleaning Procedures” later in this chapter for procedures and cautions.



## Density and Color Balance Adjustment Procedure

---

You may notice, over the course of using the printer, that colors may change. For example, reds may begin to take on a purple cast, or blues may take on a green cast. This happens during the normal use of a color printer and can be easily remedied by using the Density/Color Balance Adjustment procedure described below. This procedure, which should be done monthly, will help correct any color shifts.

This Control Panel procedure involves printing a test page and adjusting the densities and colors based on the appearance of the Test Page. You may need to repeat this procedure and test your adjustments until you achieve the desired effect.



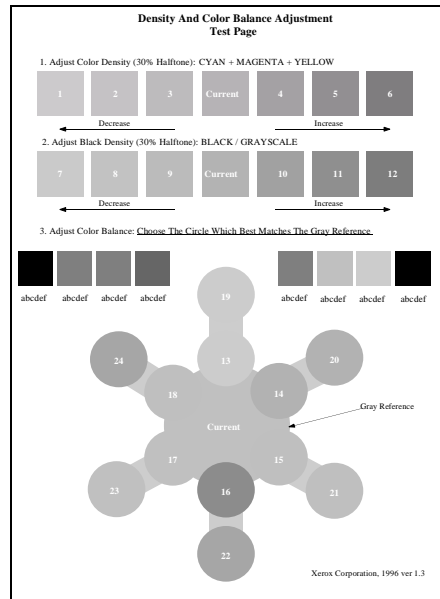
---

**NOTE:** *If, during the adjustment process, you decide to return to your starting point; you can do so by pressing the **Enter** button when <CANCEL CHANGES> is displayed.*

---

### Printing a Test Page

1. Press the **On Line** button to take the printer off line.
2. Press the **Menu** button.
3. Press the **Next** button to scroll through the Top Menu selections.
4. Press **Enter** when the Top Menu <SETUP MENU> is displayed.
5. Press the **Next** button to scroll through the sub-menu selections.
6. Press **Enter** when <COLOR ADJUST> is displayed. The Printer may go through a Print Quality adjustment and the Test Page (See Figure 7-1) will print.



**Figure 7-1: Density and Color Balance Adjustment Test Page**

The Density and Color Balance Adjustment Test Page contains numbered image that indicate possible adjustments that can be made. You can choose to make an adjustment to the Color Density, the Black Density, or the Color Balance.



**Note:** While Figure 7-1 is in black and white, the actual Density and Color Balance Adjustment Test Page is in full color.

The **Color Density** Images, numbered 1-6 and the current setting show a lightness/darkness range of three color gray 30% halftones.

The **Black Density** Images, numbered 7-12 and the current setting show a lightness/darkness range of black only 30% halftones.

The **Color Balance** Images, numbered 13-24 and the current setting, show variations of three color gray. Each of these circles contains gray with tints of other colors.

## What To Look For

There are basically three things to look for in examining the test print.

1. The **Color Density** and the **Black Density** are a matter of taste. The 30% halftones can be used to judge the current level and decide on a preference.
2. The **Color Density** and **Black Density** should be at approximately the same level. This is important in order to make the **Color Balance** adjustment.
3. The correct **Color Balance** is determined by comparing the circle in the center of the Color Balance object marked “CURRENT” with the gray background. The background is produced using black only and the circles are produced using a combination of cyan, magenta, and yellow. The objective is for the “CURRENT” circle to be the closest gray when compared to the background of any of the circles in the object, i.e., the most neutral.

## Making an Adjustment

Continue the process that you began in Step 6 (Printing a Test Page). When you print the Test Page, the <COLOR ADJUST> message is cleared and the <COLOR DENSITY> menu is displayed in the Message Display

7. Press the **Next** button to cycle through the menu choices until the feature you wish to adjust is displayed.
8. Press **Enter** to select the adjustment you desire to make. The first number in the range of choices will be displayed
9. Press **Next** until the number you have chosen as your desired setting is displayed.
10. Press **Enter** to select the number.
11. You will be asked to confirm your desire to make the change. Press **Enter** . Press **Next** to display your response. Press **Enter**.

**NO** will abort the adjustment and return you to the next item in the COLOR ADJUST menu.

**YES** will incorporate your new values and another Test Page will be printed.

12. Repeat Steps 9-13 until the “CURRENT” images appear as you want them to be.




---

**NOTE:** *You can only make one adjustment in between prints. The numbers in the boxes and circle are always in the same place. Only the values change from test print to test print.*

---

15. To complete your adjustment press **Next** until <OK ALL CHANGES> is displayed
16. Press **Enter** to accept the current settings and return to the next item in the SETUP MENU.

## Adjustment Recovery

While in the COLOR ADJUST routine you have two method of recovering previous settings:

1. You can chose to return to the values you had before you began the adjustment routine by pressing the **Enter** button when the menu item <CANCEL CHANGES> is displayed.

The printer will be restored to the original settings you had when you entered the COLOR ADJUST routine

2. You can chose to return the values to the nominal default values by pressing the Enter button when the menu item <DEFAULTS> is displayed.

The printer will be restored to the initial nominal default values.

## Cleaning Procedures

---

The cleaning procedures described in this section will help you maintain the optimum print quality and minimize downtime of your C55 printer. Before you begin, be sure that you have a basic understanding of the parts of your printer. Also, pay strict attention to the cautions given in each process.

### Cleaning the Print Drum Charger

The Print Drum Charger is a thin wire mesh used to place a charge on the Print Drum. If this mesh become dirty the Print Drum will not obtain a proper charge resulting in image quality defects. To clean the Print Drum Charger, follow the steps below.

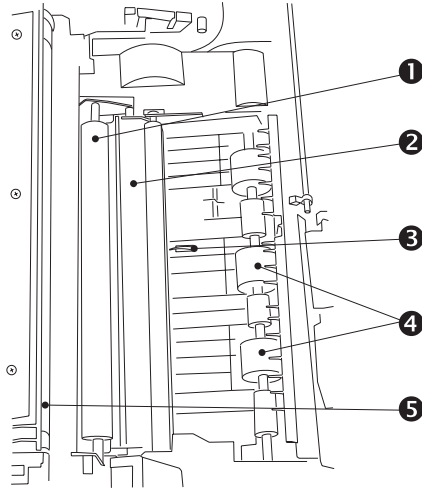
1. Open the front and top covers of the printer and locate the Print Drum.
2. On the top left side of the Print Drum you will see a green thumb tab. This is the Print Drum Charger cleaner slide.
3. Simply slide this Print Drum Charger cleaner slide back and forth several times and return it to its original location.

## Cleaning the Grounding Roller and Feed Rollers

The interior rollers, located under the Front Cover, should be cleaned only if roller marks appear on prints.



**CAUTION:** There is a small paper sensor switch in the bottom of the printer that is easily broken. Use extreme caution in this area to avoid damaging the printer. This switch can only be repaired by a service technician.



- ❶ Grounding Roller
- ❷ Registration/Precurler Roller
- ❸ Paper Sensor Switch
- ❹ Paper Feed Rollers
- ❺ Developer Rollers (underneath the Print Drum)



**CAUTION:** Do not use water or a cloth dampened with water. Use a clean, dry, lint free cloth.

Follow these steps to clean the rollers.

1. Raise the Front cover.
2. Locate the Print Drum.



**CAUTION: When removing and inserting the Print Drum, do not allow the green drum to touch any parts of the printer. Contact may damage the delicate drum degrading print quality.**

3. Release the latches on both sides of the Print Drum.
4. Grasp the Print Drum by the handles and slide it up and out of the printer, being careful to not allow the drum to come into contact with the front cover of the printer.



**CAUTION: The Print Drum is sensitive to prolonged exposure to bright light. If the drum is exposed to excessive light (the average fluorescent office lighting) for more than 2 minutes, it may require up to 2 hours of darkness to recover.**

5. Set the Print Drum Module aside on several sheets of used paper and cover the drum with several layers of paper to avoid light contact.
6. Locate the paper sensor switch in the bottom of the printer. See diagram above. Take care not to damage this switch while cleaning.
7. While holding the paper switch down, wipe all the rollers with a clean cloth.
8. Clean the areas between the developer rollers. It is not necessary to completely remove the toner from the developer rollers.
9. Hold the Print Drum with both hands by the side handles.
10. Replace the Print Drum by sliding it down and into the printer.
11. Secure both latches of the Print Drum.
12. Close the Front Cover.





## CHAPTER 8

# Optional Equipment

---

- Available Optional Equipment
- How to Install Additional Memory
- Memory Upgrade Options

Optional equipment is available which allows you to add special features to your printer or upgrade your printer system to meet your particular needs. Table 8-1 provides a brief description of each enhancement available. The part number needed to place an order can be found on the enclosed sheet.



---

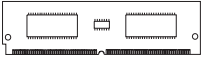
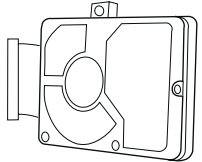
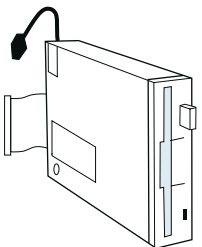
**NOTE:** *Normally, the optional equipment kits come with installation instructions. However, the memory upgrade kit instructions are included in this chapter because they are not included with the memory kits.*

---

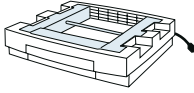
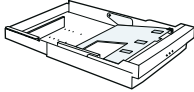
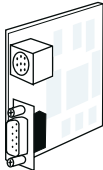
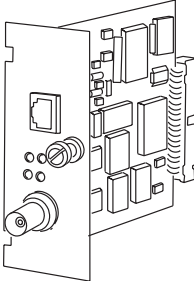
## Available Optional Equipment

To order any of the equipment listed below, call your authorized Xerox reseller.

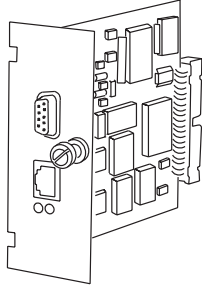
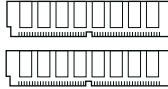
**Table 8-1: Available Optional Equipment**

Optional Kits	Content	Use	Requirements
Adobe PostScript Kit 	One - SIMM card	Allows your printer to print PostScript jobs and is required for the following features: <ul style="list-style-type: none"> <li>• Fast Blue</li> <li>• Fax Friendly Black</li> <li>• Black Overprint</li> <li>• Contone</li> <li>• Hard Drive functions</li> </ul>	Note: Comes standard in C55mp
Hard Drive 	One - Hard drive	Increases productivity of multiple-page jobs. Allows for storage of fonts and demo pages, and increases the productivity of multiple-page jobs via electronic pre-collation.	Adobe PostScript Option
Media Server 	One - 3½" HD Floppy Drive	Prints PCL 5C and PostScript files from a DOS Formatted disk.	Standard High Density, 3.5-inch, MS DOS formatted disk  To print PostScript files, you must have the PostScript Option.

**Table 8-1: Available Optional Equipment (continued)**

Optional Kits	Contents	Use	Requirements
<p>Lower Feeder</p> 	<p>One Lower Feeder assembly One Universal Tray</p>	<p>Enables Auto Tray Switching for continuous printing. Doubles paper capacity or enables dedicated transparency tray.</p>	<p>None</p>
<p>Universal Tray</p> 	<p>One - Media Tray</p>	<p>Additional media tray. Interchangeable with Tray 1 or Tray 2.</p>	<p>None</p>
<p>Serial/LocalTalk Card</p> 	<p>One - Plug in card</p>	<p>Expands connection capability to RS232 Serial port for IBM and compatible environments and LocalTalk for Macintosh environments.</p>	<p>For Macintosh: Adobe PostScript Kit</p>
<p>Ethernet Card</p> 	<p>One- Ethernet Network Interface Plug in card</p>	<p>Provides Ethernet network capability for IPX/SPX, TCP/IP, DLC/LLC, SNMP and EtherTalk protocols. Comes standard with Flash memory for easy field upgrades.</p>	<p>Note: Comes standard in C55mp</p>

**Table 8-1: Available Optional Equipment (continued)**

Optional Kits	Contents	Use	Requirements
<p data-bbox="475 243 667 275">Token Ring Card</p> 	<p data-bbox="701 243 837 390">One - TokenRing Network Interface Plug in card</p>	<p data-bbox="881 243 1127 474">Provides network capability utilizing IPX/SPX, TCP/IP, DLC/LLC, SNMP and TokenTalk protocols. Comes standard with Flash memory for easy field upgrades.</p>	
<p data-bbox="475 615 667 646">Memory Upgrade</p> 	<p data-bbox="701 615 837 705">One - 4 MB Memory SIMM</p> <p data-bbox="701 716 837 806">One - 8 MB Memory SIMM</p> <p data-bbox="701 816 837 907">One - 16 MB Memory SIMM</p> <p data-bbox="701 917 837 1008">One - 32 MB Memory SIMM</p>	<p data-bbox="881 615 1149 846">Increases the random access memory (RAM) of your printer. Improves performance and handling of large jobs. (Installation information is included in the next section.)</p>	<p data-bbox="1179 615 1339 678">Must be added in <u>pairs</u>.</p>

## How to Install Additional Memory

---

You can increase the random access memory (RAM) of your C55 printer to a maximum of 64 megabytes (MB). More RAM increases the font capability and enhances the speed of data transfer and complex page processing. Certain memory amounts are required to support enhancements to your C55 printer.

Memory kits are available in four configurations, packaged in single units each:

- 32 MB
- 16 MB
- 8 MB
- 4 MB



---

**NOTE:** *SIMMs must be installed in pairs.*

---

The C55 printer utilizes industry standard SIMMs with the following specifications:

- 72 pin, 70 ns (or faster) SIMMs
- 32 bit wide
- Symmetric Refresh only (2K block)



---

**NOTE:** *When installing memory SIMMs, the highest memory SIMM pairs must be installed in the J8 and J9 SIMM slots.*

---

## Memory Upgrade for the C55mp

Your C55mp printer comes with a total of 30 MB of memory: 8 MB of built in DRAM memory, 6 MB of Flash and an additional 16 MB of DRAM memory on SIMMs. Table 8-2 provides you with examples of how to upgrade your C55mp printer.

**Table 8-2: Typical C55mp Memory Upgrade Configuration**

TO UPGRADE TO	YOU MUST INSTALL	IN THESE COMBINATIONS
32 MB DRAM	8 MB DRAM *	8 MB in slot J8 8 MB in slot J9 * 4 MB in slot J10 * 4 MB in slot J11

Refer to Table 8-3 on page 8-9 for more details about memory configuration options.

Memory slots appear as illustrated in Figure 8-1 below when additional memory has not been installed.

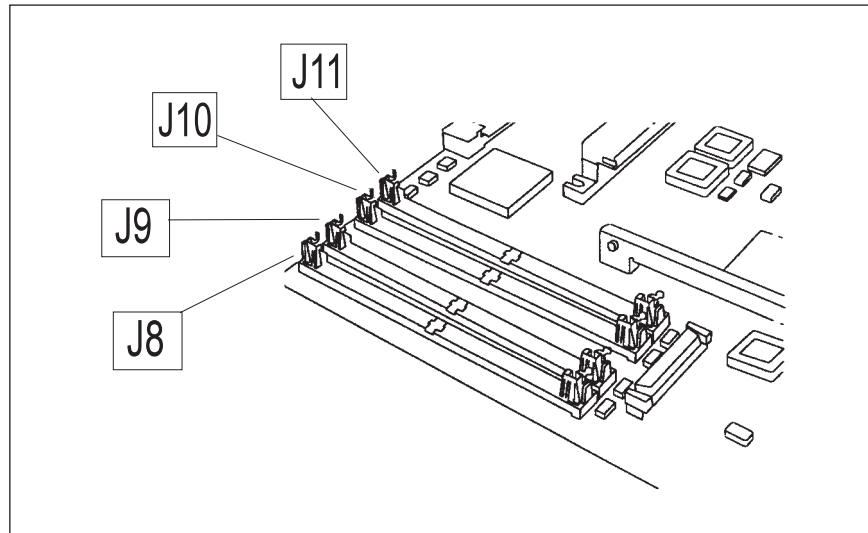


Figure 8-1: The C55/C55mp Printer Memory Board Configuration

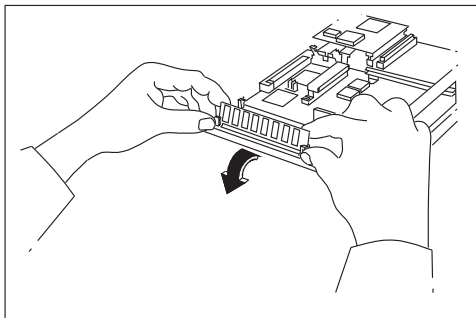
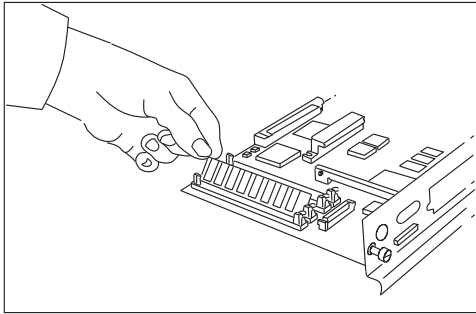
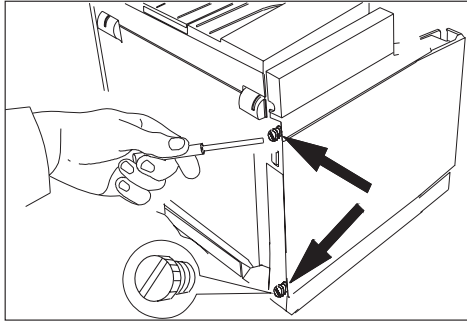
When you install additional memory in your printer, the memory SIMMs should be added in pairs by inserting them into slots contained in the pull-out panel on the rear of your printer.



---

**NOTE:** *The C55/C55mp configuration will already have two 8 MB memory SIMMs installed.*

---



## Memory Installation Procedure

Each Memory Upgrade Kit contains one memory SIMM. (Remember that you must install memory in matched sets of two, therefore, you need two kits to upgrade your printer.)

1. Switch the printer off.
2. Remove the screw on the rear of the printer that holds the pull-out panel in place.
3. Pull the panel out of the printer, and place it flat-side down on a level surface.
4. Use your index finger and thumb to grasp one end of the SIMM, and remove it from the envelope. Align the SIMM with the slot that you will install it in.
5. With both hands, grasp the ends of the SIMM between your index fingers and thumbs, and tilt it upright until it snaps into place between the end brackets on the board.
6. Repeat steps 4 and 5 to install any additional SIMMs.
7. Slide the panel back into the printer, and replace the screws.
8. Close the Front Cover, and switch the printer on again.



**NOTE:** For additional information on memory configurations, see Table 8-3.



## Memory Upgrade Options

This table lists DRAM memory upgrade options, starting with the highest memory configuration possible, and ending with the base configuration.

**Table 8-3: DRAM Memory Configurations**

Option Level	Total Memory	Slot J8	Slot J9	Slot J10	Slot J11	Comments
4-16 MB SIMM (Add 64 MB)	64	16	16	16	16	8 MB DRAM on board will turn off
2-32 MB SIMM (Add 64 MB)	64	32	32			8 MB DRAM on board will turn off
2-16 MB SIMM 2-8 MB SIMM (Add 32 MB)	56	16	16	8	8	
4-8 MB SIMM (Add 16 MB)	40	8	8	8	8	
2-8 MB SIMM 2-4 MB SIMM (Add 8 MB)	32	8	8	4	4	
Base Configuration	24	8	8			Standard in C55/C55mp

For more information about optional equipment including additional memory, contact your Xerox reseller.



## CHAPTER 9



# Network Printer Services

---

Two print service utilities are available for the installation and management of your C55 printer -- CentreWare DP and CentreWare Internet Services. Each of these services provides you with the capability to easily and quickly accomplish the following tasks with your C55 printer from your workstation:

- Check printer status
- Remotely configure, monitor, and manage the printer
- Set printer defaults
- Perform printer maintenance diagnostics remotely
- Send files to the printer without opening the original application
- Upgrade the software on your C55 printer and optional Network Interface Card

*CentreWare DP* is a new generation of network print management software designed for the network administrator. It provides a single point of administration for all Xerox desktop and network printers, including your C55 printer. Thanks to the ease of point-and-click navigation, administrators will be able to install, connect, and configure the C55 printer on a network immediately and quickly. Setup procedures have been simplified and the management of network printers is virtually effortless. CentreWare DP supports a number of key network environments, including NetWare and Windows NT.

*CentreWare Internet Services* is an interactive service that extends the capabilities of CentreWare DP using Internet technology as the platform. It provides another option for implementing advanced services for the installation, configuration, and management of your C55 printer. Each of the features in CentreWare Internet Services can be accessed through familiar client-resident software interfaces, such as Netscape Navigator or Microsoft Explorer browsers. Through a web browser, users and system administrators will be able to monitor the status of the C55 printer, print HTML-based documents, and access context sensitive on-line assistance.

For system administrators, CentreWare Internet Services will provide a faster and more productive way to install and upgrade software on your C55 printer and a wide range of supporting information on the Internet.

See the *Technical Information Guide* for more information on the operation and use of CentreWare DP and CentreWare Internet Services.



## APPENDIX A

# Safety Notes

---

- Electrical Safety
- Laser Safety
- Maintenance Safety
- Operational Safety
- Ozone Safety

The Xerox C55 color laser printer and the recommended consumable supplies have been designed and tested to meet strict safety requirements. Attention to the following notes will ensure the continued safe operation of your printer.

## Electrical Safety

---

- Use the power cord supplied with your C55 printer.
- Do not use a ground adapter plug to connect the printer to a power source receptacle that lacks a ground connection terminal.
- Plug the power cable directly into a properly grounded electrical outlet. Do not use an extension cord. If you do not know whether an outlet is grounded, ask an electrician to check the outlet.



**WARNING: You may get a severe electrical shock if you do not connect the grounding conductors correctly.**

- Do not place the printer where people may step on the power cable.
- Do not place objects on the power cable.
- Do not override or disable electrical or mechanical interlocks.
- Do not obstruct the ventilation openings. These openings are provided to prevent overheating of the printer.



**WARNING: Do not push objects into slots and openings on the printer. Making a contact with a voltage point or shorting out a part could result in fire or electrical shock.**

- If you notice unusual noises or odors, switch off the printer power immediately. Disconnect the power cable from the electrical outlet. Call an authorized Xerox service representative to correct the problem.
- If any of the following conditions occur, switch off the printer power immediately, disconnect the power cable, and call an authorized Xerox service representative.
  - The power cable is damaged or frayed.
  - Liquid is spilled into the printer.
  - The printer is exposed to water.
  - Any part of the printer is damaged.

The power cord is attached to the printer as a plug-in device at the back of the printer. In the event it is necessary to remove all electrical power from the printer, disconnect the power cord from the power receptacle.

## Laser Safety

---



**CAUTION: The use of controls or adjustments, or the performance of procedures other than those specified herein, may result in a hazardous radiation exposure.**

This equipment complies with all applicable safety standards. With specific regard to laser, the equipment complies with performance standards for laser products set by government agencies as a Class 1 laser product. It does not emit hazardous light; the beam is totally enclosed during all modes of customer operation and maintenance.

When performing various operator functions, you may see laser warning labels. These labels are for the service mode and are placed on or near panels or shields that require a tool for removal. These panels are not to be removed.



## Maintenance Safety

---

- Do not attempt any maintenance procedure that is not specifically described in the documentation supplied with your printer.
- Do not use aerosol cleaners. The use of supplies that are not approved may cause poor performance and could create a dangerous condition.
- Use the supplies and cleaning materials only as directed in this manual. Keep all of these materials out of the reach of children.
- Do not remove the covers or guards that are fastened with screws unless you are installing optional equipment. There are no parts that you can maintain or service behind these covers.
- Follow the maintenance procedures provided in Chapter 7.

## Operational Safety

---

Your Xerox printer and supplies were designed and tested to meet strict safety requirements. These include safety agency examination, approval, and compliance with established environmental standards.

Your attention to the following safety guidelines will help to ensure the continued safe operation of your printer.

- Use the material and supplies specifically designed for your printer. The use of unsuitable materials may result in poor performance and possibly a hazardous situation.
- Follow all warnings and instructions marked on, or supplied with, the printer.

## SAFETY NOTES

- Place the printer in a dust free area where the temperature range is 50° F to 90° F (10° C to 32° C) and the relative humidity is 15% to 85%.
- Choose a location for the printer allowing sufficient space around the printer for operation and maintenance. The minimum recommended room size is 10 cubic meters/353 cubic ft. or approximately 8 ft. x 8 ft. x 8 ft. / 242 cm x 242 cm x 242 cm.
- Place the printer in an area where there is adequate space for ventilation and servicing. The recommended minimal spacing is 10 in. (25 cm) behind the printer, 10 in. (25 cm) on either side of the printer, and 24 in. (61 cm) in front of the printer.
- Do not place the printer near a heat source.
- Do not place the printer in direct sunlight.
- Do not place the printer in line with the cold air flow from an air conditioning system.
- Place the printer on a level, solid surface with adequate strength for the weight of the machine. The machine weight without any packaging materials is 89 pounds (40 kg).
- The printer is heavy. Exercise care in moving or relocating the printer.

- Follow the recommended procedure when moving the printer from one location to another.
- Do not put containers of coffee or other liquids onto the printer.
- Do not block or cover the slots and openings on the printer. Without adequate ventilation, the printer may overheat.



**WARNING: Be careful when working in areas identified with this warning symbol. These areas may be very hot and could cause personal injury.**

- Frequent operation of the on/off switch is not recommended.
- Keep hands, hair, and neckties away from the exit feed rollers.
- Do not remove a media tray while printing from a single tray configuration.
- Do not open the Top Cover while printing.
- Do not switch off the printer power while printing.
- Do not move the printer while printing.

## Ozone Safety

---

This printer produces ozone during normal operation. The ozone produced is heavier than air, and the quantity is dependent on copy volume. Providing the proper environmental parameters, as specified in the Operational Safety section of these Safety Notes, ensures that concentration levels meet safe limits.

If you need additional information about ozone, request the Xerox publication, OZONE, 600P83222, from your Xerox Authorized Reseller or Xerox Support.



APPENDIX B

# Special Notices

---

- FCC Notices... USA
- Certifications... Canadian
- European Markets
- Safety Extra Low Voltage Safety Approval

## FCC Notices...USA

---

### Radio Frequency

#### **BASE PRINTER AND BASE PRINTER WITH ETHERNET**

This equipment generates, uses, and can radiate radio frequency energy, and, if not installed and used in accordance with the instruction manuals, may cause interference with radio communications. The equipment has been tested and found to comply with the limits for a Class B digital device pursuant to Part 15 of the FCC rules, which are designed to provide reasonable protection against such interference, when the equipment is operated in a residential environment. However, there is no guarantee that interference will not occur in a particular installation. If the equipment does cause harmful interference with radio or television reception, which can be determined by turning the equipment off and on, the user is encouraged to try to correct the interference by one or more of the following measures:

- Reorient or relocate the receiving antenna.
- Increase the separation between the equipment and the receiver.
- Connect the equipment into an outlet on a circuit different from that to which the receiver is connected.
- Consult the dealer or a experienced radio/TV technician for help.

Changes or modifications to this equipment not specifically approved by the Xerox Corporation may void the authority granted by the FCC to operate this equipment.

Shielded cables must be used with this equipment to maintain compliance with FCC regulations.

**BASE PRINTER WITH TOKEN RING AND/OR BASE  
PRINTER WITH SERIAL/LOCAL TALK CARD**

This equipment has been tested and found to comply with the limits for a Class A digital device, pursuant to Part 15 of the FCC rules. These limits are designed to provide reasonable protection against harmful interference when the equipment is operated in a commercial environment. This equipment generates, uses, and can radiate radio frequency energy and, if not installed and used in accordance with the instruction manual, may cause harmful interference to radio communications. Operation of this equipment in a residential area is likely to cause harmful interference in which the user will be required to correct the interference at his own expense.

## Certifications...Canadian

---

### 60 HZ, 115V

The equipment is listed by the Underwriters Laboratories, UL 1950, certified by Canadian Standards Association, CSA22.2, No. 950

## European Markets

---

### CE Certification

The CE marking applied to this product symbolizes Rank Xerox Declaration of Conformity with the following applicable directives of the European Union as of the dates indicated:

January 1, 1995: - Council Directive 73/23/EEC amended by Council Directive 93/68/EEC, approximation of the laws of the member states related to low voltage equipment.

January 1, 1996: - Council Directive 89/336/EEC, approximation of the laws of member states related to electromagnetic compatibility.

A full declaration, defining the relevant Directives and referenced standards, can be obtained from your Rank Xerox representative.

Changes or modifications to this equipment not specifically approved by Rank Xerox Corporation may result in non-compliance with one or more of the directives listed above.

Shielded cables must be used with this equipment to maintain compliance with the EMC directive (89/336/EEC).

### Ethernet/Token Ring/Serial/LocalTalk Accessories



**WARNING: This is a Class A product. In a domestic environment, this product may cause radio interference, in which case the user may be required to take adequate measures.**



**CISPR**

<b>Configuration</b>	<b>Specification</b>
Base Printer	CISPR-B
Base Printer with Hard Drive	CISPR-B
Base Printer with Media Server	CISPR-B
Base Printer with Ethernet	CISPR-A
Base Printer with Token Ring	CISPR-A
Base Printer with Serial/LocalTalk	CISPR-A

## **Safety Extra Low Voltage Safety Approval**

---

The C55 printing system is in compliance with various governmental agencies and national safety regulations. All system ports meet the requirements for Safety Extra Low Voltage (SELV) circuits for connection to customer-owned devices and networks.

Additions of customer-owned or third-party accessories attached to the system must meet or exceed the requirements listed above.

Since this system consists of several modules requiring external connection, it must be installed per the Xerox Installation procedure.

A P P E N D I X C



# Printer Technical Specifications

---

- Physical Specifications
- Environmental Specifications
- Electrical Specifications
- Performance Specifications
- Controller Specifications

## Physical Specifications

---

### Dimensions (without Optional Lower Feeder)

- 18.5" (w) x 16.5" (d) x 16.5" (h)
- 470 mm (w) x 419 mm (d) x 419 (h)

### Weight (without Optional Lower Feeder)

- 89 lbs. (40 kg)

### Optional Tray Dimensions

- 18" (w) x 17" (d) x 4" (h)
- 460 mm (w) x 432 mm (d) x 102 mm (h)

### Optional Tray Weight

- 20 lbs. (9.1 kg)

## Environmental Specifications

---

### Temperature

- Operating: 50° to 90° F (10 to 32° C)
- Storage: 14° to 104° F (-10 to 40° C)

### Humidity

- Operating: 15% to 85% RH
- Storage: 10% to 90% RH

### Sound Level

- 54 dbA Running (Max.)
- 47 dbA Standby (Max.)

## Electrical Specifications

---

### Power Requirements

- 110–130V, 50/60 Hz, 15 A,
- 200–260V, 50/60 Hz, 10–15 A,
- Energy Star Compliant

### Power Consumption

- 300 W av. / 1000 W max.

## Performance Specifications

---

### Resolution

- Black: 600x600 dpi / Contone (PostScript only)
- Color: 600x600 dpi / Contone (PostScript only)

### Print Speed

- Black: up to 12 ppm (pages/min)
- 2 Color: up to 6 ppm
- 4 Color: up to 3 ppm

## Controller Specifications

---

AMD 29040 RISC processor, operating at 50/25 MHz

### Memory

- 24 MB DRAM / 6 MB FLASH ROM Standard on C55/C55mp
- Upgradable to a maximum of 64 MB

### Printer Description Languages (PDL)

- Standard on C55: PCL 5C (Optional Adobe PS II Upgrade)
- Standard on C55mp: PCL 5C and Adobe PS II Coresident

### Resident Fonts

- 35 Type 1 (PostScript only)
- 35 Intellifonts (PCL 5C)
- 10 TrueType (PCL 5C)

### Interfaces

- Standard: P1284 parallel with ECP, Unidirectional, Nibble & Reverse Byte Modes (Windows 95 Plug and Play Standard)
- Optional: LocalTalk and Serial
- Optional: Ethernet/Token Ring



# Index

---

## A

- Adobe PostScript Kit.....5-2
  - as optional equipment.....8-2
- Advanced features (PostScript) .....5-20

## B

- Bi-directional
  - printing .....2-5
- Bitmaps
  - Photo Color (PCL 5C) .....5-4
  - ImageFix (PostScript).....5-21
- Black and White
  - PCL 5C .....5-4
  - PostScript.....5-11
- Black Developer Unit
  - location .....2-13
- Black Overprint
  - description .....5-20
  - PCL 5C / PostScript comparison.....5-3
  - requirements .....8-2
- Buttons (Control Panel) .....4-2
  - descriptions .....4-5
  - locations.....4-3

## C

- C1 to C3 error codes ..... 6-5
- C55 Printer
  - manuals for ..... 1-7
  - memory upgrade..... 8-6
- Cancel a job ..... 4-10
- CentreWare DP.....3-7, 9-1, 9-2
- CentreWare Internet Services.....9-1, 9-2
- Charts .....5-4, 5-13
- Cleaning
  - Feed Rollers ..... 7-9
  - Grounding Roller ..... 7-9
  - Print Drum Charger ..... 7-8
  - procedures ..... 7-1
- Clearing jams..... 6-11
- CMYK
  - how to disable coverage limit..... 5-20
- Collation
  - PCL 5C / PostScript comparison..... 5-3
- Color Adjustment
  - PCL 5C ..... 5-8
  - PostScript..... 5-17
- Color balance
  - adjustment procedure..... 7-3
  - PCL 5C ..... 5-9
  - PostScript..... 5-18

Color Developer	
how to check status.....	4-15
Color Developer Unit	
location .....	2-13
Color features	
printer drivers for .....	5-2
Color matching systems	
available for TS printers .....	2-6
with Unadjusted (PCL 5C).....	5-5
with Unadjusted (PostScript) .....	5-15
Color Mode Options	
defaults.....	4-12
Color options	
PCL 5C .....	5-4
PostScript.....	5-13
Color settings	
PCL 5C .....	5-4
PostScript.....	5-13
Color space	
use of.....	5-20
Colors	
how to adjust between (PCL 5C).....	5-9
how to adjust between (PostScript) .....	5-18
how to adjust contrast (PostScript).....	5-17
how to adjust lightness (PCL 5C) .....	5-8
how to adjust lightness (PostScript) .....	5-17
how to adjust saturation (PCL 5C).....	5-8
how to adjust saturation (PostScript).....	5-17
how to correct imbalance.....	7-3
COMMUNICATIONS .....	4-11
Components	
external .....	2-8
internal.....	2-13
Connectivity.....	2-5
Consumables	
instructions.....	6-3
Contone	
description.....	5-16
memory requirements .....	5-16
PCL 5C / PostScript comparison.....	5-3
requirements .....	8-2
Contrast	
Color Adjustment (PostScript).....	5-17
CONTROL MENU .....	4-10
Control Panel	
Density/Color Balance Adjustment	
procedure .....	7-3
description.....	4-2
examples of use .....	4-13
how to designate custom paper size.....	4-17
indicator lights .....	4-4
location .....	2-8
menus.....	4-9
Message Display Window.....	4-3
use of.....	4-7
Control Panel Buttons	
descriptions .....	4-5
location .....	4-3
Control Panel Menu	
how to print.....	4-14
Conventions	
for this User's Guide .....	1-5
CorelDRAW .....	5-21
Covers	
how to open .....	2-11
locations .....	2-8
<b>D</b>	
Defaults	
Color Mode Options .....	4-12
imaging.....	4-12
set and customize.....	4-10
Defects	
print .....	6-18
reducing the number of.....	6-18
table listing.....	6-19
Density	
adjustment procedure.....	7-3
Density and Color Balance	
Adjustment Test Page.....	7-4
Disable CMYK Limit.....	5-20
Dots per inch (dpi) .....	2-4
Double-sided prints .....	3-5
Duplex printing.....	3-5



**E**

E1 - TRAY 1 JAM.....	6-17
E1 to E9 error codes.....	6-5
E2 - TRAY 2 JAM.....	6-17
E4 - INPUT JAM.....	6-15
E5 - FUSER JAM.....	6-13
E6 - DRUM JAM.....	6-15
E7 - DRUM JAM.....	6-15
E8 - OUTPUT JAM.....	6-13
Edge guide	
Manual Feed Tray.....	3-12
media trays.....	3-4
Edge Smoothing	
PCL 5C.....	5-6
PCL 5C / PostScript comparison.....	5-3
PostScript.....	5-21
Enhanced Alignment	
PCL 5C.....	5-6
PCL 5C / PostScript comparison.....	5-3
Enter button.....	4-6, 4-8
Envelopes	
printing.....	3-11
recommended.....	3-3
Equipment	
optional.....	8-1
ERROR.....	4-5
Error messages	
description.....	6-4
table listing.....	6-5
Ethernet Card	
as optional equipment.....	8-3
Expert Color Control	
PCL 5C.....	5-8
PCL 5C / PostScript comparison.....	5-3
PostScript.....	5-17

**F**

F1 to F3 error codes.....	6-7
Fast Blue	
description.....	5-14
PCL 5C / PostScript comparison.....	5-3
requirements.....	8-2

**Fax Friendly Black**

description.....	5-14
PCL 5C / PostScript comparison.....	5-3
requirements.....	8-2
Features	
printer.....	2-3
Feed Rollers	
cleaning.....	7-9
Fonts	
resident.....	2-4, 4-10
Form Feed button.....	4-5
Form Feed light	
description.....	4-4
location.....	4-3
Four Color Toner indicator lights	
location.....	4-3
Front Cover	
how to open.....	2-11
location.....	2-8
Fuser	
location.....	2-13
Fuser Cleaner Roller	
location.....	2-13
Fuser Cover	
how to open.....	2-12
location.....	2-8
Fuser Oil Kit	
location.....	2-13

**G**

Graphics	
Color Settings (PCL 5C).....	5-4
Color Settings (PostScript).....	5-13
Graphs.....	5-4, 5-13
Grayscale	
PCL 5C Color Setting.....	5-5
PostScript Color Setting.....	5-13
Grounding Roller	
cleaning.....	7-9

**H**

- H1 to H3 error codes ..... 6–8
- Halftone Settings
  - PCL 5C ..... 5–7
  - PostScript ..... 5–16
- Hard Drive
  - as optional equipment ..... 8–2
- Help, On-line ..... 1–7
- Hold Job ..... 4–5
  - PCL 5C ..... 5–6

**I**

- ImageFix ..... 5–21
  - PCL 5C / PostScript comparison ..... 5–3
- IMAGING ..... 4–12
  - defaults ..... 4–12
- Indicator lights
  - description ..... 4–4
  - location ..... 4–2
- Installation
  - of C55 printer ..... 1–7
  - of memory ..... 8–5
- Instructions
  - for replacement items ..... 6–3
- Intelligent Color 3.0
  - PCL 5C ..... 5–4
  - PostScript ..... 5–13
- Interface Connectors ..... 2–9
- Interfaces
  - networking ..... 2–5

**J**

- JA, J1 to J9 error codes ..... 6–8
- Jams
  - areas jams occur ..... 6–12
  - how to clear ..... 6–11
  - reducing the number of ..... 6–11
  - transparencies ..... 6–11

**L**

- Labels
  - jams from ..... 3–11

- printing ..... 3–11
  - recommended ..... 3–3
- Languages
  - changing default ..... 4–11
- LEDs
  - descriptions ..... 4–4
  - location ..... 4–3
- Letterhead
  - loading in Manual Feed Slot ..... 3–11
  - loading in tray ..... 3–6
- Lightness
  - Color Adjustment (PCL 5C) ..... 5–8
  - Color Adjustment (PostScript) ..... 5–17
- Lights
  - on Control Panel ..... 4–2
- Loading
  - envelopes ..... 3–11
  - labels ..... 3–11
  - letterhead in tray ..... 3–6
  - media in Manual Feed Slot ..... 3–11
  - paper in tray ..... 3–4
  - transparencies in tray ..... 3–7
- Local Talk Connector ..... 2–10
- Lower Feeder ..... 4–16
  - as optional equipment ..... 8–3
  - electrical connection ..... 2–9

**M**

- Maintenance
  - regular ..... 7–2
- MAINTENANCE (menu selection) ..... 4–10
- Maintenance items
  - how to check status ..... 4–15
  - instructions ..... 6–3
- Manual Feed Slot
  - description ..... 3–8
  - how to use ..... 3–11
  - location ..... 2–8
  - media for ..... 3–3
  - transparencies ..... 3–3
  - tray for ..... 3–9
- Manual Feed Tray
  - description ..... 3–9

- how to attach .....3-10
- Manuals
  - for C55 printer .....1-7
- Media
  - envelopes .....3-3
  - for use in Manual Feed Slot.....3-3
  - for use in trays.....3-2
  - labels.....3-3
  - paper.....3-2
  - transparencies .....3-3
- Media Exit Area
  - location .....2-8
- MEDIA MENU .....4-10
- Media Server .....4-12
  - application-specific settings with.....4-22
  - as optional equipment.....8-2
  - description .....4-18
  - how to print from .....4-20
  - location .....2-8
  - Print to File.....4-19
  - upgrade .....4-18
- Media Server button.....4-5
- Memory
  - configurations .....8-9
  - how to install.....8-5
  - required for specific resolution .....8-9
  - SIMMs .....8-5
  - SIMMs placement .....8-9
- Memory Upgrade
  - as optional equipment.....8-4
  - for C55 printers .....8-6
  - options .....8-9
- Menu button .....4-5
- Menu map
  - how to print.....4-14
- Menu navigation.....4-5, 4-7
- Menus
  - description .....4-9
  - navigation of .....4-7
  - selections.....4-10
  - sub-menu selections.....4-9
- Message Display Window
  - location .....4-3
  - selecting menus in .....4-6
- MULTINATIONAL.....4-11
- N**
  - Navigation
    - of Control Panel menus .....4-7
  - Network
    - connectivity .....2-5
  - Network Activity LEDs.....2-10
  - Network configuration
    - establishing .....4-11
  - Network setup
    - of C55 printer .....1-7
  - Networking
    - to expand capability.....8-3
  - Next button .....4-6
- O**
  - Object Oriented Rendering
    - PCL 5C / PostScript comparison.....5-3
  - OFF LINE.....4-5
  - On Line button.....4-5
  - On Line light
    - description.....4-4
    - location .....4-3
  - On/Off Switch
    - location .....2-9
  - On-Line Help.....1-7
  - Optional equipment.....8-1
  - Orientation
    - envelopes.....3-11
    - labels.....3-11
    - letterhead in Manual Feed Slot .....3-11
    - letterhead in tray .....3-6
    - paper in tray .....3-5
  - Ozone Filter
    - location .....2-13
- P**
  - PageMaker.....5-21
  - Pages per minute (ppm) .....2-3
  - Paper
    - for use in Manual Feed Slot.....3-3

- for use in trays..... 3–2
  - loading in Manual Feed Slot.....3–11
  - loading in tray ..... 3–4
  - orientation in tray ..... 3–5
  - Paper size
    - adjustment for in trays ..... 3–4
  - Parallel port .....2–10
  - Parts
    - external ..... 2–8
    - internal.....2–13
  - PAUSED ..... 4–5
  - PCL 5C
    - color options..... 5–4
    - features..... 5–3
    - printer drivers ..... 5–2
  - Photo Color
    - PCL 5C ..... 5–4
  - PostScript
    - color options.....5–13
    - features..... 5–3
    - printer drivers ..... 5–2
    - upgrade .....4–19
  - Power cord receptacle
    - location ..... 2–9
  - Pressure plate..... 3–5
  - Previous button ..... 4–6
  - PRINT .....4–10
  - Print defects .....6–18
    - table listing .....6–19
  - Print Drum
    - exposure to light.....6–12
    - location .....2–13
  - Print Drum Charger
    - cleaning ..... 7–8
  - Print modes
    - Grayscale (PCL 5C)..... 5–5
    - Grayscale (PostScript) .....5–13
    - Save Toner (PCL 5C) ..... 5–5
    - Save Toner (PostScript).....5–15
    - Unadjusted (PCL 5C) ..... 5–5
    - Unadjusted (PostScript) .....5–15
  - Print speed ..... 2–3
  - Print to File..... 4–19
  - Printer
    - cleaning..... 7–1
    - connectivity ..... 2–5
    - features..... 2–3
    - parts of, external..... 2–8
    - parts of, internal ..... 2–13
    - regular maintenance ..... 7–2
    - specifications ..... 2–6
  - Printer drivers
    - color features ..... 5–1
  - Printing
    - from Manual Feed Slot ..... 3–11
    - network ..... 2–5
    - problems..... 6–1
    - protocols..... 2–5
  - Problems
    - printing ..... 6–1
- Q**
- Quad Dot
    - PCL 5C ..... 5–7
    - PostScript ..... 5–16
  - Quick Installation Guide ..... 1–7
  - Quick Network Setup Guide ..... 1–7
- R**
- RAM.....8–4, 8–5
  - Rear Cover
    - how to open ..... 2–12
    - location ..... 2–8
  - Reset the printer..... 4–10
  - Resident fonts ..... 2–4, 4–10
  - Resolution
    - memory requirements ..... 8–9
    - standard..... 2–4
  - Resources
    - for C55 printer..... 1–7
  - Restore Settings
    - PCL 5C ..... 5–10
    - PostScript ..... 5–19

RS232 Serial Connector.....	2-10
<b>S</b>	
Safety	
for troubleshooting .....	6-2
Safety Certification label.....	2-9
Saturation	
Color Adjustment (PCL 5C).....	5-8
Color Adjustment (PostScript).....	5-17
Save Settings	
PCL 5C.....	5-10
PostScript.....	5-19
Save Toner	
PCL 5C / PostScript comparison.....	5-3
print mode (PCL 5C).....	5-5
print mode (PostScript) .....	5-15
Select button .....	4-6
Serial Number	
location .....	2-13
Serial/LocalTalk Card	
as optional equipment.....	8-3
SERVICE .....	4-12
Settings	
how to designate custom paper size .....	4-17
SETUP .....	4-11
SIMMs	
installation .....	8-5
memory board configuration.....	8-7
Smooth Screen	
PCL 5C.....	5-7
PostScript.....	5-16
Special Options	
print mode (PostScript) .....	5-19
Specifications	
printer.....	2-6
Speed	
printing.....	2-3
Status	
how to check .....	4-10
of Color Developer .....	4-15
of Maintenance Items .....	4-10
Support Brochure .....	1-7
<b>T</b>	
T0 to T2 error codes.....	6-10
Technical Information Guide .....	1-7
Test page	
Color Balance.....	7-3
Test patterns	
printing .....	4-12
Token Ring Card	
as optional equipment.....	8-4
Token Ring Connector .....	2-10
Toner	
excessive amounts .....	5-20
lights indicating status.....	4-4
Toner Collector	
location .....	2-13
Toner Indicators	
description.....	4-4
Toner Refill Doors	
location .....	2-13
Transparencies	
for use in Manual Feed Slot.....	3-3
for use in trays.....	3-3
jams .....	6-11
loading in tray .....	3-7
Transparency tray	
checking through Bi-Directional Comm.....	5-31
description.....	3-7
how to designate.....	4-16
Tray	
for Manual Feed Slot .....	3-9
letterhead in .....	3-6
transparencies in .....	3-7
Tray 1	
location .....	2-8
Tray Switching	
PCL 5C .....	5-6
Trays	
media for .....	3-2
paper in .....	3-4
Troubleshooting	
preliminary considerations.....	6-2

## I N D E X

safety..... 6-2  
sources of help.....6-24  
suggested actions..... 6-1

## *U*

### Unadjusted

print mode (PCL 5C)..... 5-5  
print mode (PostScript).....5-15

### Universal Tray

as optional equipment..... 8-3

### Upgrade

Adobe Kit..... 5-2  
Media Server.....4-18  
memory .....8-1, 8-4  
PostScript.....4-19

Use Application Color Space.....5-20

## *V*

### Vivid Color

PCL 5C ..... 5-4  
PostScript.....5-13

Voltage Information label ..... 2-9

## *W*

W1 to W5 error codes .....6-10

## *X*

### Xerox Intelligent Color 3.0

PCL 5C / PostScript comparison..... 5-3