Xerox DocuPrint 4050/4090 IPS Installation Planning Guide

**THE DOCUMENT COMPANY
XEROX**

Version 7.1
August 2000
721P89020

Xerox Corporation
701 South Aviation Boulevard
El Segundo, CA 90245

©2000 by Xerox Corporation. All rights reserved.

Copyright protection claimed includes all forms and matters of copyrightable material and information now allowed by statutory or judicial law or hereinafter granted, including without limitation, material generated from the software programs which are displayed on the screen, such as icons, screen displays, looks, etc.

Printed in the United States of America.

Publication number: 721P89020

Xerox®, The Document Company, the stylized X, and all Xerox product names mentioned in this publication are trademarks of Xerox Corporation. Products and trademarks of other companies are also acknowledged.

Changes are periodically made to this document. Changes, technical inaccuracies, and typographic errors will be corrected in subsequent editions.

Laser safety



Warning: Adjustments, use of controls, or performance of procedures other than those specified herein may result in hazardous light exposure. ⚠

The Xerox DocuPrint printers are certified to comply with the performance standards of the U.S. Department of Health, Education, and Welfare for Class 1 laser products. Class 1 laser products do not emit hazardous radiation. The DocuPrint printers do not emit hazardous radiation because the laser beam is completely enclosed during all modes of customer operation.

The laser danger labels on the system are for Xerox service representatives and are on or near panels or shields that must be removed with a tool. **DO NOT REMOVE LABELED PANELS OR PANELS NEAR LABELS. ONLY XEROX SERVICE REPRESENTATIVES HAVE ACCESS TO THESE PANELS.**



Ozone information

This product produces ozone during normal operation. The amount of ozone produced depends on copy volume. Ozone is heavier than air. The environmental parameters specified in the Xerox installation instructions ensure that concentration levels are within safe limits. If you need additional information concerning ozone, call 1-800-828-6571 to request the Xerox publication 600P83222, *OZONE*.

Operation safety

Your Xerox equipment and supplies have been designed and tested to meet strict safety requirements. They have been approved by safety agencies, and they comply with environmental standards. Please observe the following precautions to ensure your continued safety.

- Always connect equipment to a properly grounded electrical outlet. If in doubt, have the outlet checked by a qualified electrician.



Warning: Improper connection of the equipment grounding conductor may result in risk of electrical shock. ⚠

- Never use a ground adapter plug to connect equipment to an electrical outlet that lacks a ground connection terminal.
- Always place equipment on a solid support surface with adequate strength for its weight.

-
- Always use materials and supplies specifically designed for your Xerox equipment. Use of unsuitable materials may result in poor performance and may create a hazardous situation.
 - Never move either the printer or the Printer Controller without first contacting Xerox for approval.
 - Never attempt any maintenance that is not specifically described in this documentation.
 - Never remove any covers or guards that are fastened with screws. There are no operator-serviceable areas within these covers.
 - Never override electrical or mechanical interlocks.
 - Never use supplies or cleaning materials for other than their intended purposes. Keep all materials out of the reach of children.
 - Never operate the equipment if you notice unusual noises or odors. Disconnect the power cord from the electrical outlet and call service to correct the problem.

If you need any additional safety information concerning the equipment or materials Xerox supplies, call Xerox Product Safety at the following toll-free number in the United States:

1-800-828-6571

For customers outside the United States, contact your local Xerox representative or operating company.

Table of Contents

Laser safety	iii
Ozone information	iii
Operation safety	iii
Introduction	ix
About this guide	ix
Contents	ix
Conventions	x
Notice	x
1. Product overview	1-1
System overview	1-1
4050/4090 IPS hardware features	1-3
NPS/IPS Dual Mode	1-4
Sixth Sense	1-5
Base system components	1-6
2. Controller components and options	2-1
Controller hardware	2-1
Sun Ultra 2 workstation	2-1
Sun Ultra 60 workstation	2-4
IPS user interface screen	2-8
Host Channel Unit (HCU)—channel-attached systems only	2-10
3. Printer components and options	3-1
Printer components	3-1
Printer control console	3-3
Printer options	3-4
High-capacity feeder	3-4
Dual stacker	3-5
Stitcher/stacker	3-6
4. Preparing for installation	4-1
Responsibilities	4-1
Xerox responsibilities	4-1
Customer responsibilities	4-2
Installation planning checklist	4-4
Connectivity requirements	4-7
Ethernet specifications	4-7

	Token Ring specifications	4-7
	Channel-attached specifications	4-7
5.	Controller specifications and requirements	5-1
	Power requirements	5-1
	Outlet configurations	5-2
	Environmental specifications	5-3
	Space requirements	5-3
	Printer controller placement	5-3
	Controller hardware specifications and requirements summary	5-8
6.	Printer specifications and requirements	6-1
	Power requirements	6-1
	Outlet configurations	6-2
	Printer outlet voltages—60 Hz	6-2
	Printer outlet voltages—50 Hz	6-3
	Environmental specifications	6-4
	Space requirements	6-5
	Printer placement	6-6
	Space planning guidelines	6-10
	Clearance space requirements	6-10
	Shared space	6-10
	Floor leveling	6-14
	Delivery access requirements	6-14
	Printer hardware specifications and requirements summary	6-17
	Space planning templates	6-19
7.	System connections	7-1
	Cable lengths	7-1
	Cable locations	7-2
	Channel attachments	7-2
8.	Installation	8-1
	Installation process	8-1
	Your responsibilities	8-2
	Defining the IPS printer to the host	8-3
	Software licensing	8-3
	Ongoing maintenance	8-4
	Routine maintenance	8-4
	Meter reading and reporting	8-4

A. Supplies	A-1
Paper and other throughput stocks	A-1
Selecting paper	A-1
Paper care	A-3
Other supplies	A-6
Dry ink	A-6
Fuser lubricant	A-6
Developer	A-6
Diskettes	A-6
Cartridge tapes	A-6
Fonts	A-7
Consumable supplies tables	A-8
Paper and special stocks tables	A-8
Complete supplies list—4050/4090 printers	A-11
Ordering supplies	A-12
B. Xerox support services	B-1
Xerox Customer Service Support Center	B-1
Xerox Printing Systems Customer Support Center	B-2
Xerox Customer Documentation Catalog	B-3
Xerox Documentation and Software Services (XDSS)	B-3
Operator training	B-3
Xerox Customer Education	B-4
Xerox Font Center	B-4
C. Related publications	C-1
D. Defining the channel-attached printer to the host	D-1
MVS parameters	D-1
OS/2 procedures	D-4
AIX procedures	D-5
VM sample definitions	D-6
VSE sample definitions	D-6
E. Defining the printer to the host: TCP/IP attachment	E-1
MVS or OS/390 parameters	E-1
Software prerequisites – MVS	E-1
Network configurations – MVS	E-1
Configuration steps – MVS	E-2
1. Configure the IPS printer for TCP/IP at the GUI	E-2
2. Configure the MVS CCU for the MVS host to MVS	E-2
3. Configure the PSF printer in JES2 or JES3	E-2
4. Configure the printer in PSF/MVS	E-7

	5. Configure TCP/IP for MVS for the printer	E-11
	6. Test the printer to ensure it prints from the MVS host	E-14
	Correcting for printer performance issues – MVS	E-16
	References	E-17
AS/400 parameters		E-18
	Software prerequisites – AS/400	E-18
	Network configurations – AS/400	E-18
	Configuration steps – AS/400	E-19
	1. Configure the IPS printer for TCP/IP at the GUI	E-19
	2. Create the PSF/400 configuration	E-19
	3. Create the printer device description – AS/400	E-20
	4. Test the printer connection – AS/400	E-22
	Correcting for printer performance issues – AS/400	E-24
	References – AS/400	E-24
AIX parameters		E-25
	Software prerequisites – AIX	E-25
	Network configurations – AIX	E-26
	Configuration steps—AIX	E-26
	References	E-27
OS/2 parameters		E-28
	Software prerequisites – OS/2	E-28
	Network configurations – OS/2	E-28
	Configuration steps – OS/2	E-29
	1. Configure the printer for TCP/IP in OS/2	E-29
	2. Provide TCP/IP routing information if necessary	E-29
	3. Define the printer to PSF/2	E-30
	4. Define a PSF/2 print queue for the printer (optional)	E-31
	5. Test the printer connection in OS/2	E-32
	Correcting for printer performance issues – OS/2	E-34
	References – OS/2	E-35

Glossary GLOSSARY-1

Index INDEX-1

This *Xerox Printing Systems Installation Planning Guide* helps you prepare for delivery and installation of your new Xerox DocuPrint printing system.

About this guide

This guide is intended for the person responsible for coordinating the installation of the DocuPrint printer at your site. It lists the tasks you must complete before installation can begin, as well as your responsibilities during the installation.

Before using this guide, become familiar with its contents and conventions.

Contents

This guide contains the following:

- Chapter 1, "Product overview," provides an overview of the DocuPrint 4050 and 4090 printing systems.
- Chapter 2, "Controller components and options," describes system controller hardware, software, and options.
- Chapter 3, "Printer components and options," describes printer components, configurations, and options.
- Chapter 4, "Preparing for installation," provides a checklist of tasks that must be accomplished before the installation. It also explains connectivity requirements for transporting documents from the host or client to the DocuPrint printing system.
- Chapter 5, "Controller specifications and requirements," describes power, environmental, and space requirements for the system controller.
- Chapter 6, "Printer specifications and requirements," describes power, environmental, and space requirements for the printer. Space planning guidelines and diagrams are provided to help you set up the work area.
- Chapter 7, "System connections," provides cable requirements for your DocuPrint 4050 and 4090 printing systems..
- Chapter 8, "Installation," describes the activities that occur during installation. It also describes ongoing maintenance activities.
- Appendix A, "Supplies," describes how to select, store, and use supplies for the DocuPrint printing system. It also provides a list of consumable supplies you can order.

- Appendix B, "Xerox support services," explains how to utilize available Xerox support services.
- Appendix C, "Related publications," lists other Xerox documents that are part of this publication set.
- Appendix D, "Defining the channel-attached printer to the host," provides explanations and sample printer parameters for defining your channel-attached printer to your host.
- Appendix E, "Defining the printer to the host: TCP/IP attachment," provides instructions, prerequisites, and sample printer parameters for defining your TCP/IP-attached printer to your host.

A glossary and index are provided at the back of the guide.

Conventions

This document uses the following conventions:

Italics—Document and library names are shown in italics (for example, the *Xerox DocuPrint IPS Series Messages Guide*).



Note: Notes are hints that help you perform a task or understand the text.



Caution: Cautions alert you to an action that could damage hardware or software. 



Warning: Warnings alert you to conditions that may affect the safety of people. 

Notice

This publication may contain descriptions of concepts and features not currently available for your Xerox printing system. Consult your Xerox sales representative or your operating system software program description for additional information.

1. Product overview

This chapter provides an overview of the features and functions of the Xerox DocuPrint 4050 IPS and the 4090 IPS.

System overview

The Xerox DocuPrint 4050 IPS and 4090 IPS are cut-sheet, duplex printers that are fully compatible with the IBM AFP architecture. They accept an IPDS data stream from any PSF eligible platform, including MVS, VM, VSE, OS/2, OS/400 (with TCP/IP only), and AIX. They are plug-compatible in the AFP/IPDS environment, and emulate an IBM IPDS Group 3 page printer with the AFIG (Advanced Function Image and Graphics) option.

The IPS printer series is a combination of proven Xerox print engines matched with a high-performance RISC-based controller. Each system consists of a Sun workstation controller and the printer, sometimes referred to as the Image Output Terminal (IOT).

Host environments

The IPS emulates an IBM AFP Group 3 page printer with the Advanced Function Image and Graphics (AFIG) option and can print in all the following PSF environments:

- MVS
- VM (channel-attached only)
- VSE (channel-attached only)
- OS/2
- OS/400 (with TCP/IP only)
- AIX



Note: Although PSF/VSE does not support TCP/IP directly, a printing system with PSF/2, PSF/6000, or InfoPrint Manager can attach to a PSF/VSE system and the PSF/2, PSF/6000, or InfoPrint Manager can furnish the TCP/IP support for the IPS printer. □



Note: There is no minimum host operating system software level required to support IPS. The minimum PSF levels needed to support the IPS are:

- PSF/MVS: V2.1
- PSF/VM: V2.1
- PSF/VSE: V2.2
- PSF/400: V3.2
- PSF/6000: V2.1
- PSF/2: V2.0

The DocuPrint IPS can be set up to receive data from the IBM host in one of two ways:

- Through a bus and tag channel connection.



Note: If your system will be channel-attached, the printer controller requires an additional component called a Host Channel Unit (HCU), which interfaces between the IBM host and the IPS controller.

- Through a Token Ring or Ethernet interface using TCP/IP (the HCU is not used).



Note: A transmission rate of at least 16 megabits per second should be used with a Token Ring interface on the IPS. (Overall performance depends on network traffic and job density.)

- The software supports Token Ring over TCP/IP, and Ethernet over TCP/IP, with the exception of VM and VSE platforms.
- Of the other platforms that support TCP/IP, only the RS/6000 supports 100 Mb Ethernet connectivity.



Note: Customers can have multiple connectivities (Token Ring, Ethernet, or Bus and Tag), but only one type of connectivity can be active at any given time.

Data is printed at production speeds:

- **4850 IPS:** Up to 50 pages per minute (ppm)
- **4890 IPS:** Up to 92 pages per minute (ppm).

A full-color graphical user interface on the Sun workstation enables interaction with the IPS.

Figure 1-1. **Xerox 4050/4090 IPS: channel-attached configuration**

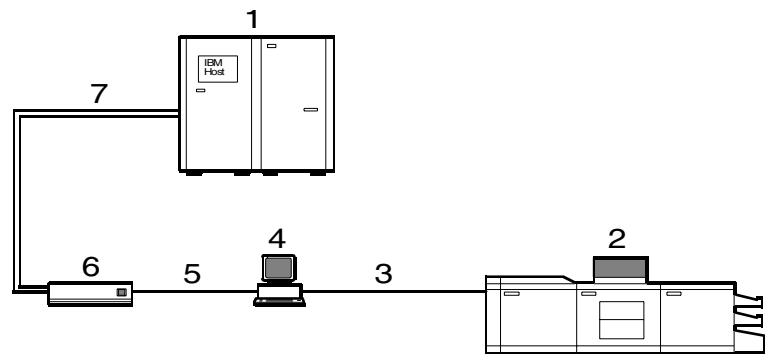

- 1 Host system (PC or mainframe)
- 2 4050 or 4090 IPS printer
- 3 Printer interface cable (DCIM2)
- 4 Sun workstation controller
- 5 SCSI interface
- 6 Host Channel Unit (HCU)
- 7 Bus and tag cables

Figure 1-2. 4050/4090 IPS: TCP/IP configuration

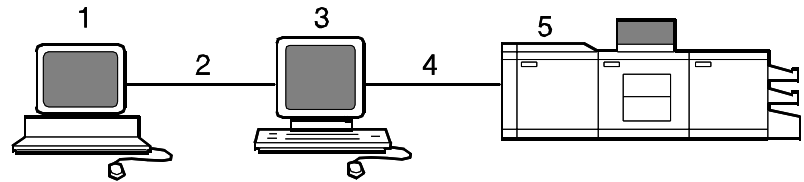

- 1 Host system (PC or mainframe)
- 2 Token Ring or Ethernet network connection
- 3 Sun workstation controller
- 4 Printer interface cable (DCIM2)
- 5 4050 or 4090 IPS printer

For information on the various IPS printer configuration options, refer to the “Printer components and options” chapter of this guide.

4050/4090 IPS hardware features

The 4050/4090 IPS provide numerous features that can be accessed with standard AFP compatible software products. The following features are available and can be enabled or configured using the graphical user interface on the printer controller:

- **Up to four input trays** — Two addressable input trays are standard with the printing system. Two additional feeder trays are available as options. These trays can be used to configure print jobs in the most effective manner. For example, the trays can be used to provide nonstop printing of a complex job that requires multiple paper stocks, or only a few paper stocks, but using the continuous loading capability of the input trays. A different tray can also be selected for each copy of a specific page in a print job; for example, to provide different paper colors for specific pages.

Feeder tray capacities, based on 20-pound or 80 gsm (grams per square meter) bond, are:

- **Tray 1:** 1000 sheets
- **Tray 2:** 500 sheets
- **High-capacity feeder trays (3 and 4):** 1000 sheets each.

- **Advanced paper handling** — The IPS can handle paper stocks ranging in size from 8 by 10 inches / 203 by 254 mm to 8.5 by 14 inches / 216 by 356 mm, including A4, and in weight from 20-pound or 80 gsm bond to 110-pound / 200 gsm index. Jobs can also be printed on special stocks such as labels and transparencies.

The printer engine monitors the print job so that, should a paper jam occur, the job resumes on the correct page, providing complete document integrity.

- **300 dpi resolution** — The 4050 and 4090 IPS provide high print quality at 300 dpi resolution. They can receive data at 240 or 300 dpi; 240 data is converted to 300 by the controller.

The IPS must be configured to the same font resolution as the host input data stream (refer to your *4050/4090 IPS Guide to Configuring and Managing the System* for instructions on configuring for the correct input resolution). Conflicts between the input font resolution and the IPS configuration could result in inability to print the job, or in variable data missing from the output.



Note: You will normally achieve better print quality by converting all 240 dpi fonts and other resources to 300 dpi before printing, rather than leaving the conversion for the controller to do. However, you should always run test prints to validate your particular applications. □

- **Sixth Sense Remote Service** — The Xerox Sixth Sense Remote Service feature allows Xerox support personnel to access IPS/NPS controller via modem from a remote location. More information about Remote Service can be found in the *Xerox DocuPrint 4050/4090 IPS Troubleshooting Guide*.
- **Choice of dual or stitcher stacker** — Your 4050/4090 IPS is available with one of two stacker types: a dual stacker, with two output trays, or a stitcher/stacker which can place a wire stitch in sets of up to 50 sheets.

Output tray capacities, based on 20-pound or 80 gsm bond, are:

- **Dual stacker trays 1 and 2:** 750 sheets each
- **Stitcher/stacker:** 2000 sheets.

NPS/IPS Dual Mode

The Xerox DocuPrint Dual Mode option enables both DocuPrint IPS and NPS systems to coexist on the same printer controller (Sun workstation). This allows the DocuPrint system to receive data streams supported by NPS and IPS, including IPDS, PostScript Levels 1 and 2, HP PCL5c, HP PCL5e, and ASCII.

Either of the following two types of configurations may be used:

- The same Token Ring or Ethernet connection can be used for both IPDS (IPS) and Postscript/PCL (NPS).
- Both a Token Ring card and an Ethernet card can reside in the Sun workstation controller, with one being used for IPDS and the other for PostScript/PCL.

The customer may switch from one mode to the other. When your system is operating in IPS mode, it can accept PostScript and PCL data streams in the background; however, you can print these jobs only when the system is in NPS mode. When in NPS mode, the system cannot accept IPDS data streams in the background; you can print them only when the system is in IPS mode.

Refer to the *Xerox DocuPrint IPS/NPS Dual Mode Switching Instructions* and other Xerox DocuPrint IPS documentation for more information.

Sixth Sense

Sixth Sense is a unique suite of diagnostic tools that allows Xerox customer service engineers, analysts, and consultants to serve customers more effectively.

Sixth Sense is intended to automate and expedite the range of service-related support functions. Sixth Sense is a tool that enables Xerox to provide benchmark service support. Xerox customers benefit from the ability to bring broader support to focus more quickly.

For example, Sixth Sense can allow the Service Representative to repeatedly "preview" the condition of the system prior to an actual site visit. This may provide the ability to determine the correct part or piece of information to have on hand when the site visit is made.

Sixth Sense is a no charge feature available to customers through Xerox Service. The customer need only provide an analog phone line for use by the Sixth Sense modem connection. For those customers unable to dedicate a phone line to the Sixth Sense connection, three and five port phone share devices are available for purchase.

To take advantage of Sixth Sense, the customer needs to:

- Request Sixth Sense enablement through Xerox Service
- Provide an analog phone line
- If necessary, purchase an optional phone share device.

More information about the Sixth Sense can be found in the *Xerox DocuPrint 4050/4090 IPS System Administration Guide*.

Base system components

The IPS system consists of the following major components:

- **Printer controller** — The printer controller (also called the system controller) accepts IPDS data from the host, processes the data, and sends the data to the printer engine using the IPS operating system. The controller provides the printer with print data and commands, and receives status information from the printer.
- **Printer** — The printer, also called the Image Output Terminal (IOT), accepts formatted pages of data from the printer controller and performs the imaging and printing of documents. The printer also provides paper stacking, collating, and optional finishing capabilities you enable using the IPS application software accessed through the graphical user interface.

2. Controller components and options

The printer controller provides the printer with print data and commands, and receives status information from the printer. This chapter describes the components and options available for the controller.

Controller hardware

The printer controller consists of a Sun workstation and, if you are printing data received over a channel, a Host Channel Unit (HCU). The controller uses proprietary Xerox hardware, firmware, and software to run the IPS.

Your controller may be either a Sun Ultra 2 or Ultra 60 workstation. The following sections contain information about both the Ultra 2 and the Ultra 60.

Sun Ultra 2 workstation

The Sun workstation provides a user interface to the print engine. It is used to operate the IPS software which controls the printer. The workstation contains the following hardware components:

- Sun Ultra 2 workstation processor (system unit)
- Display monitor
- Keyboard and mouse
- Connectivity boards for Ethernet and, optionally, Token Ring
- A Data Control Interface Module (DCIM2) card installed in the processor to interface with the print engine.

Figure 2-1. Components of the Sun Ultra 2 workstation

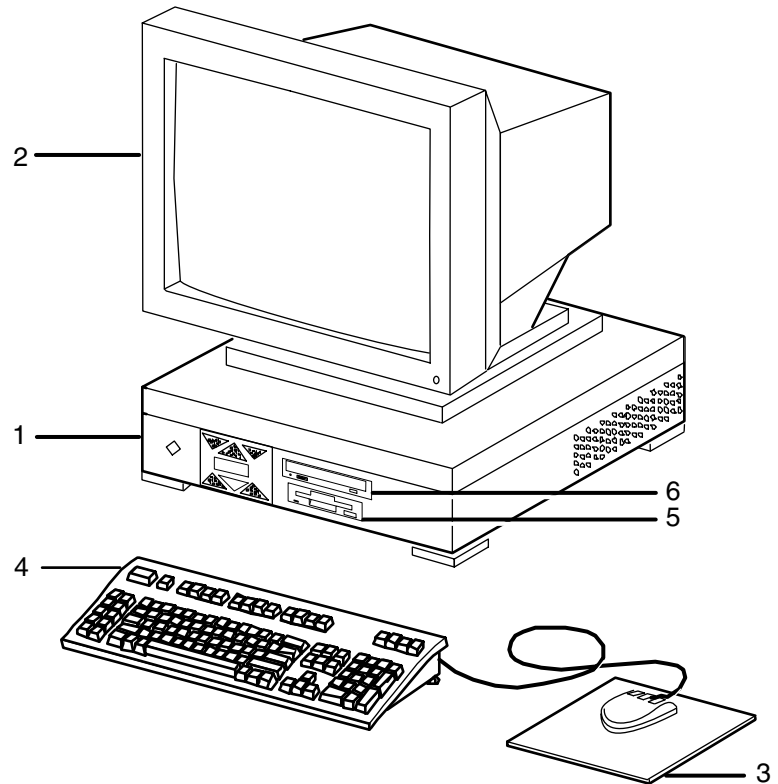

- 1 Processor
- 2 Monitor
- 3 Mouse and mouse pad
- 4 Keyboard
- 5 Diskette drive
- 6 CD-ROM drive

Processor

The processor is the central processing unit of the Sun workstation. It contains a power switch, an internal disk drive, a diskette drive, a CD-ROM drive, a power receptacle and outlet, connectors and ports.

The processor has the following components:

- **Internal disk drive:** One high-speed internal disk drive is provided as a standard feature of the processor. The operating system, the IPS application, and any queued print jobs are stored on the internal disk. This disk cannot be used to store other applications or data except as directed by your service representative.
- **Diskette drive:** Diskettes inserted into a diskette drive are used to load files to, and back up files from, the internal disk drive. The diskette drive uses industry standard 3.5 inch, 1.44 Mb, double-sided, high-density diskettes. This diskette drive is not an input source for print jobs nor any other data or application; it is reserved exclusively for use by a service representative to update software and to store files. The diskette drive is located in the processor, on the right front section for the Ultra 2.

- **CD-ROM drive:** The CD-ROM drive is a high density, read-only, optical laser storage device used for loading the IPS operating system and other files. The CD-ROM drive is located in the processor above the floppy drive.
- **Cartridge tape drive (not shown):** An optional 8 GB, 4 mm SCSI cartridge tape drive also is available for the IPS. Like the diskette and CD drives, this tape drive is not an input source for print jobs or for any other data or application. It provides the service representative with another means of loading system maintenance files or saving diagnostic information.



Caution: When installing a cartridge drive on an IPS with a host channel unit (HCU), the tape drive must be “daisy-chained” to the HCU. In this situation, do not attempt to run both the tape drive and the HCU at the same time. 

- **Back panel:** The back panel of the processor has a power switch, a power receptacle and outlet, connectors, connector openings, and ports. The following figure shows the back panel of the Sun workstation that is part of your IPS controller.

Figure 2-2. **Back panel of the Sun Ultra 2 processor**

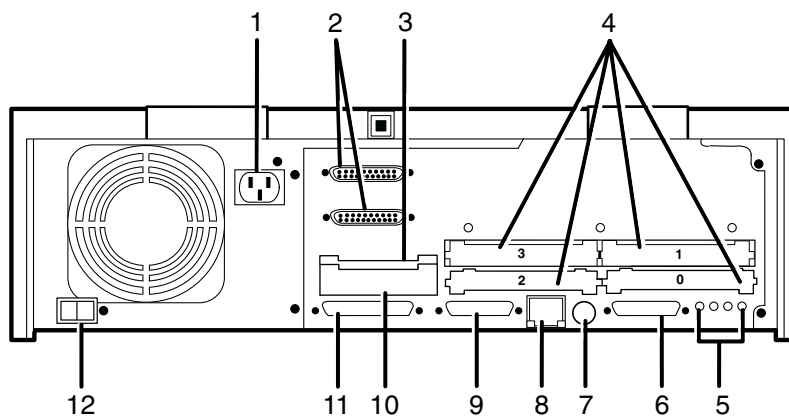

- 1 **Power inlet**
- 2 **Serial connectors (2): RS-432/RS-232**
- 3 **Graphics/video output: UPA slot**
- 4 **Sbus slots** (Number of slots varies depending on the model)
- 5 **Audio connectors (4)**
- 6 **Parallel connector**
- 7 **Keyboard/mouse connector**
- 8 **TPE connector**
- 9 **MII connector**
- 10 **UPA slot**
- 11 **SCSI connector**
- 12 **Power on/Standby switch**



Note: The controller back panel contains two serial ports on one DB-25 connector. Both ports are used exclusively by the IPS software for diagnostic purposes. The ports and diagnostic software are accessed only by the service representative.

Display monitor The display monitor has a 1192 x 700 pixel screen which displays the IPS graphical user interface windows.

Keyboard The keyboard consists of alphanumeric keys similar to a typewriter, symbols and special character keys, an extended character set, and function keys. The keyboard is one of your main methods of communicating with the printer. You can use the keyboard to make selections, and to enter commands that control functions such as requesting sample prints, obtaining billing meter totals, shutting down the system, and so forth.

Mouse The mouse is another main method of communicating with the printer. The mouse has three buttons. The left and right buttons are used to select NPSIPS functions. The center button provides additional functions that you will not be required to use. If your workstation has an optical mouse, it must remain on its designated metallic pad to be active. If the mouse has a roller ball instead of an optical sensor underneath, it requires a non-metallic pad.



Note: Printer controller hardware configurations are subject to upgrade.

Sun Ultra 60 workstation

The Sun Ultra 60 workstation provides a user interface to the print engine. It has a high performance RISC processor chipset, based on the industry standard Scalable Processor Architecture (SPARC). It is used to operate the software that controls the printer. The workstation contains the following hardware components:

- Sun Ultra 60 workstation processor (system unit)
- Display monitor
- Keyboard and mouse
- Diskette, CD-ROM, and cartridge tape drives
- Connectivity board for Ethernet and, optionally, Token Ring
- A Data Control Interface Module (PDCIMu) card installed in the processor to interface with the print engine.

Figure 2-3. Components of the Sun Ultra 60 workstation

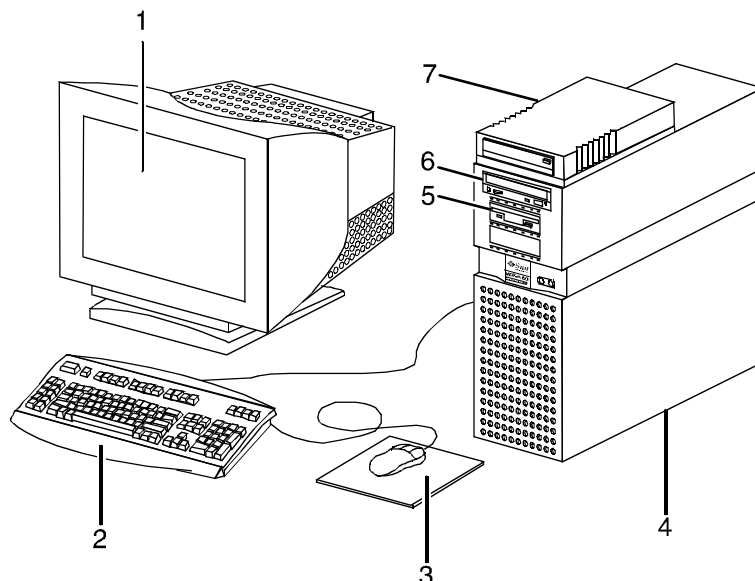

- 1 Monitor
- 2 Keyboard
- 3 Mouse
- 4 Processor
- 5 Diskette drive
- 6 CD-ROM drive
- 7 Cartridge tape drive

Processor The 256 MB RAM processor is the central processing unit of the Sun Ultra 60 workstation. It contains a power switch, a disk drive, a diskette drive, a CD-ROM drive, a power receptacle and outlet, connectors and ports.

The processor has the following components:

- **Internal disk drive:** Two 18.2 GB primary disk drives are provided as a standard feature of the processor. The operating system, the IPS application, and any queued print jobs are stored on the internal disk. This disk cannot be used to store other applications or data except as directed by your service representative.
- **Diskette drive:** Diskettes inserted into a diskette drive are used to load files to, and back up files from, the internal disk drive. The diskette drive uses industry standard 3.5 inch, 1.44 MB, double-sided, high-density diskettes. This diskette drive is not an input source for print jobs nor any other data or application; it is reserved exclusively for use by a service representative to update software and to store files.
- **CD-ROM drive:** The CD-ROM drive is a high density, read-only, optical laser storage device used for loading the IPS operating system and other files. The CD-ROM drive is located in the processor above the diskette drive.

- **Cartridge tape drive:** A 4 GB external SCSI quarter inch cartridge (QIC) tape drive is an external device provided with the printing system. The cartridge tape drive connects to the controller through the SCSI port on the processor back panel. Like the diskette and CD drives, this tape drive is not an input source for print jobs or for any other data or application. You use it to load resource files, and the service representative uses it to load system maintenance files or to save diagnostic information.

Figure 2-4. **External cartridge tape drive**

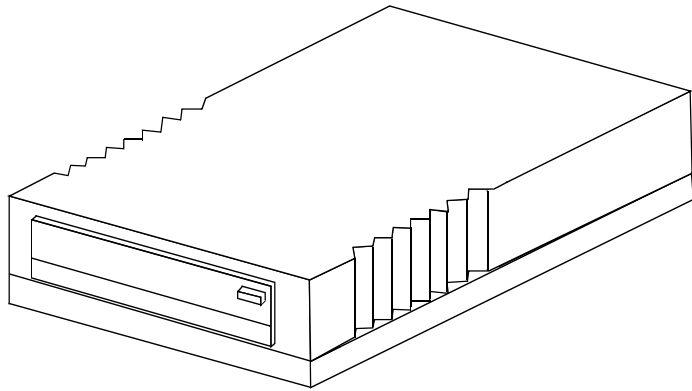

- **Back panel:** The back panel of the processor has a power receptacle and outlet, connectors, connector openings, and ports. The following figure shows the back panel of the Sun Ultra 60 workstation that is a part of your IPS controller.

Figure 2-5. Back panel of the Sun Ultra 60 processor

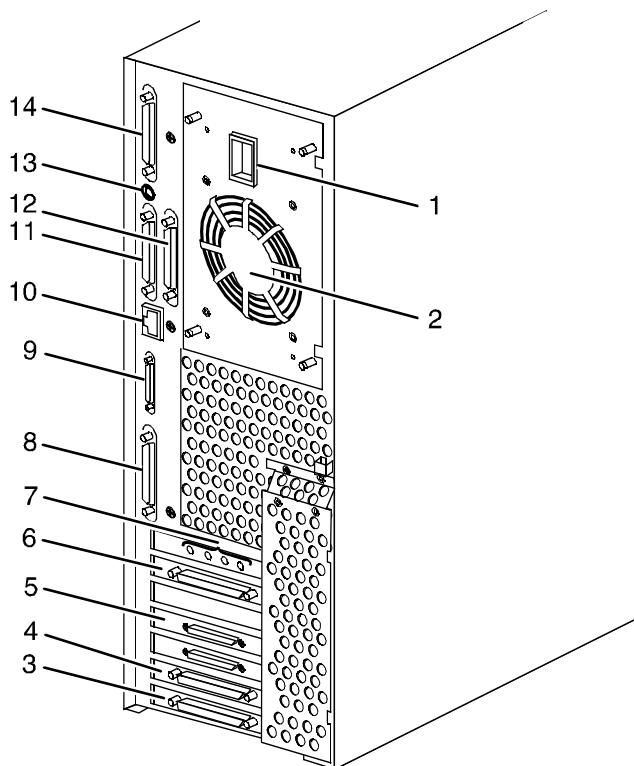

- 1 Power inlet
- 2 Fan vent
- 3 Online interface (if configured)
- 4 Differential SCSI PWB (optional)
- 5 Printer connector (PCI66 1)
- 6 Monitor connector
- 7 Audio connectors (4)
- 8 Single-ended SCSI connector
- 9 MII connector
- 10 TPE (Ethernet) connector
- 11 Serial connector A: RS-432/RS-232
- 12 Serial connector B: RS-432/RS-232
- 13 Keyboard connector
- 14 Parallel connector

Display monitor The graphical user interface allows you to interact with the printer and to monitor its interaction with the various components. During a print job, printer error messages may display to notify you of any unexpected conditions.

Keyboard The keyboard consists of alphanumeric keys similar to a typewriter, symbols and special character keys, an extended character set, and function keys. The keyboard is one of your main methods of communicating with the printer. You can use the keyboard to make selections, and to enter commands that control functions such as requesting sample prints, obtaining billing meter totals, shutting down the system, and so forth.

Mouse The mouse is another main method of communicating with the printer. The mouse has three buttons. The left and right buttons are used to select IPS functions. The center button provides additional functions that you will not be required to use. If your workstation has an optical mouse, it must remain on its designated metallic pad to be active. If the mouse has a roller ball instead of an optical sensor underneath, it requires a non-metallic pad.



Note: Printer controller hardware configurations are subject to upgrade.

IPS user interface screen

The graphical user interface allows you to interact with the printer and to monitor its interaction with the various components. During a print job, printer error messages may display to notify you of any unexpected conditions.

The following graphic shows the 4050/4090 IPS user interface screen.

Figure 2-6. IPS user interface screen

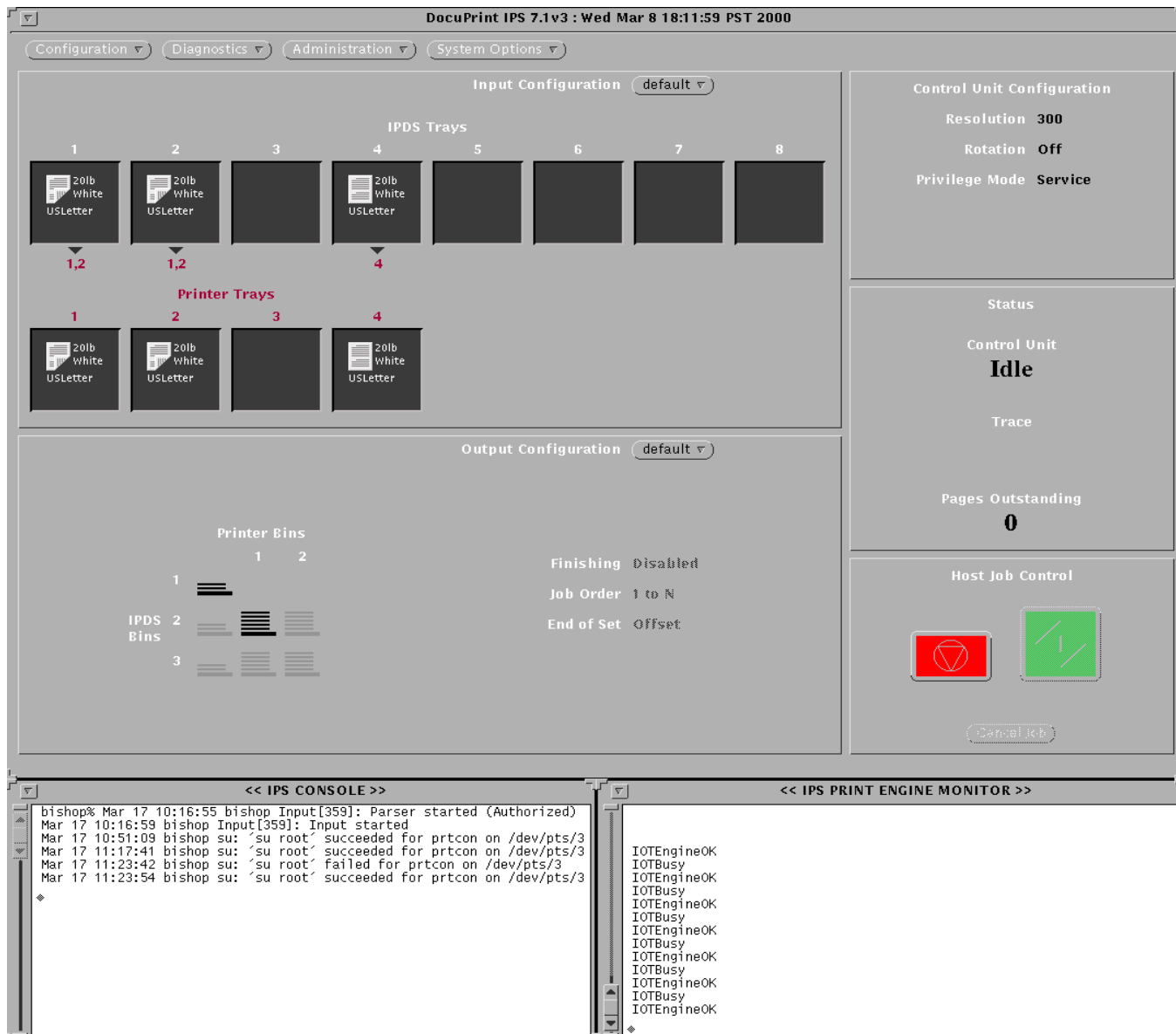

The IPS console window displays the system messages. The IPS print engine monitor window monitors the current printer state and displays messages such as a broken or jammed printer, printer ready, paper trays, engine faults, and other messages about the condition of the printer.

The IPS main window provides access to the IPS menus and tray grouping windows. These menus and windows in turn provide access to the task subwindows from which system operation and administration tasks are performed.

Host Channel Unit (HCU)—channel-attached systems only

The HCU handles all of the IPDS communications and handshaking with PSF on the host when the IPS is receiving data over a channel. (It is not used when the IPS is printing data using TCP/IP.) The following figure illustrates the HCU component.

Figure 2-7. **Host Channel Unit (HCU)**

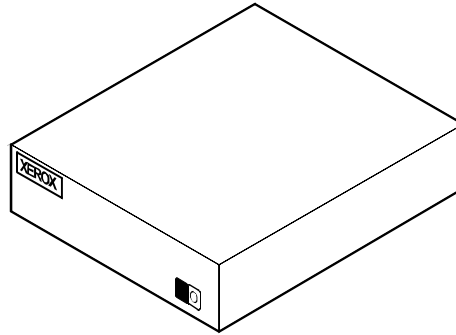

- The front panel of the HCU provides a single-digit LED display which enables you to monitor power-up and offline status, and alerts you to error conditions. (Refer to your *IPS Messages Guide* for an explanation of the HCU codes displayed here.)
- The back panel of the HCU has a power switch and outlet, S/370 bus and tag cable input and bypass connectors, and a dual serial port. In addition, there are two switches on the back panel to set channel printing to high or low. The power supply is a standard switching power supply capable of 10 amps on the 5 volt output.



Note: The customer is responsible for obtaining, stringing, and maintenance of the bus and tag cables. The bus and tag cables must be fully populated cable sets.

3. **Printer components and options**

The printer processes the electronic data and images received from the controller and produces the printed report. This chapter describes the components and options available for the printer.

Printer components

The printer is the part of the DocuPrint printing system that processes the electronic data and images received from the printer controller and produces the printed report.

The standard 4050 and 4090 printer components are the printer control console, the sample tray, the feeder trays, and the stacker trays. Labels are located throughout the printer to assist you with a variety of tasks such as clearing a paper jam. The printer also has the capability to sound an audible tone to direct your attention to a printer problem. Your service representative can adjust the volume of this tone.

The printer provides control buttons and displays for basic printer functions and status information. The printer control console contains message and graphic displays that assist you with jam clearance and printer maintenance.

Figure 3-1. 4050/4090 printer shown with dual stacker trays

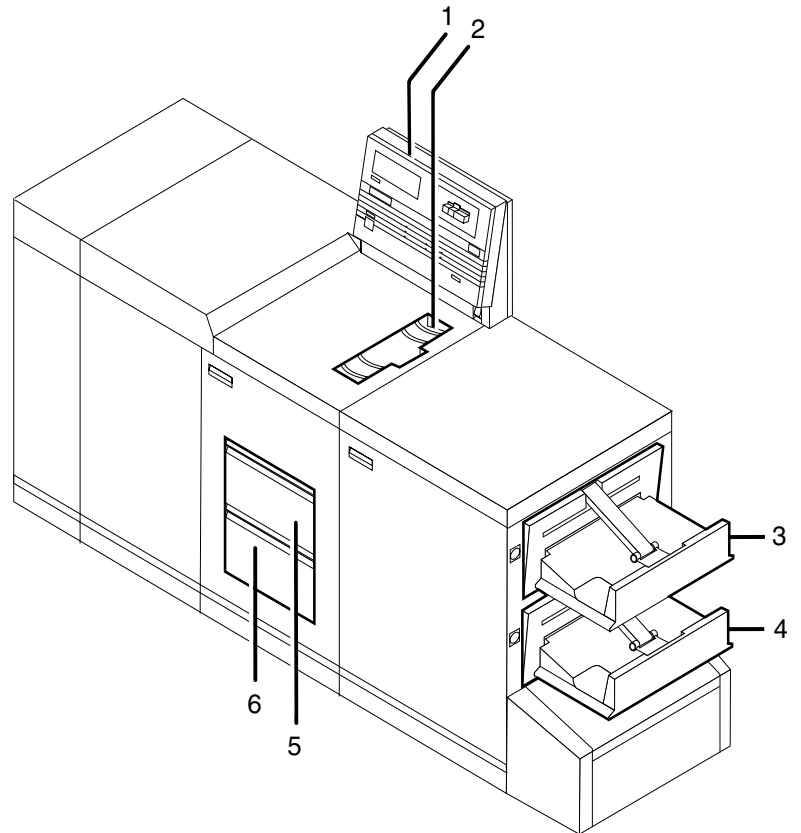

- 1 **Printer control console**
- 2 **Sample tray**
- 3 **Stacker tray 1**
- 4 **Stacker tray 2**
- 5 **Feeder tray 1**
- 6 **Feeder tray 2**

Refer to the *System Overview* manual for a detailed description of the features and operation of the printer components.

Printer control console

The printer control console contains message and graphic displays, as well as status indicator lights that alert you to printer conditions, paper jams, and other fault and status conditions (such as low dry ink). Other indicator lights show which feeder tray is active and the paper size in use. These indicators and the Information button help you to solve printer problems.

Also on this console are Stop and Continue buttons, which allow you to stop printing and resume an interrupted job without returning to the workstation controller. This gives you temporary control of the printer without interrupting input processing.

Figure 3-2. 4050/4090 printer control console

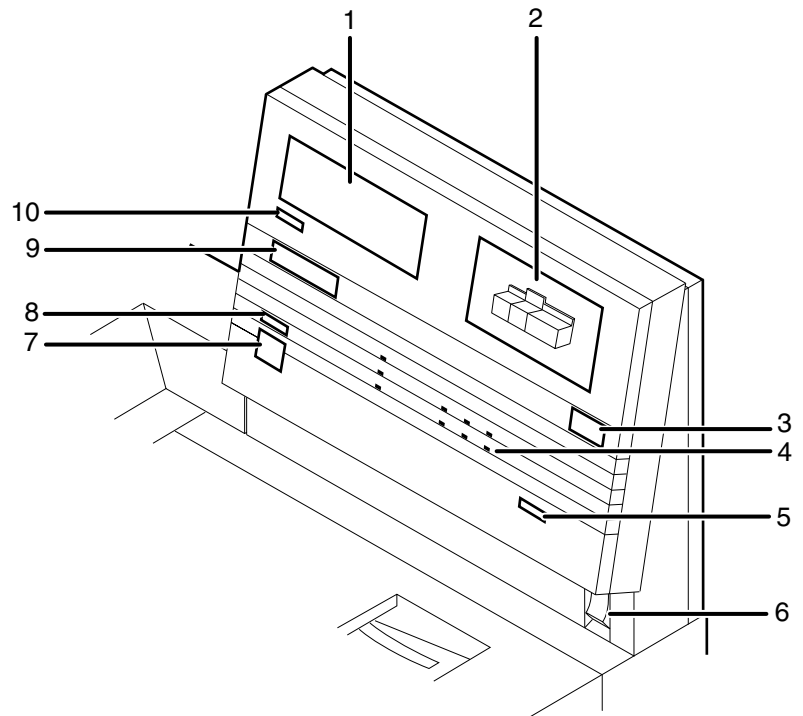

- 1 Attention light
- 2 Message display
- 3 Graphic display
- 4 Wire percentage indicator
- 5 Feeder tray indicators
- 6 Power on/off switch
- 7 Sample button (disabled)
- 8 Continue button
- 9 Stop button
- 10 Fault code display
- 11 Information button

Refer to the *System Overview* manual for a detailed description of the features and operation of the printer control console components.

Printer options

All 4050 and 4090 printers are available with the following options:

- High-capacity feeder
- Dual stacker or stitcher/stacker

In addition, the LPS 4050/4090 printers are available with the bypass transport option.

These options allow you to customize your printing system for increased efficiency and for specialized applications.

High-capacity feeder

Two feeder trays are provided as part of the printer base configuration (feeder trays 1 and 2). For the DocuPrint Models 4050 and 4090, the high-capacity feeder option increases the versatility and productivity of the printer with two additional feeder trays (trays 3 and 4), increasing the feeder capacity by approximately 2,000 sheets.

Figure 3-3. 4050/4090 with high-capacity feeder

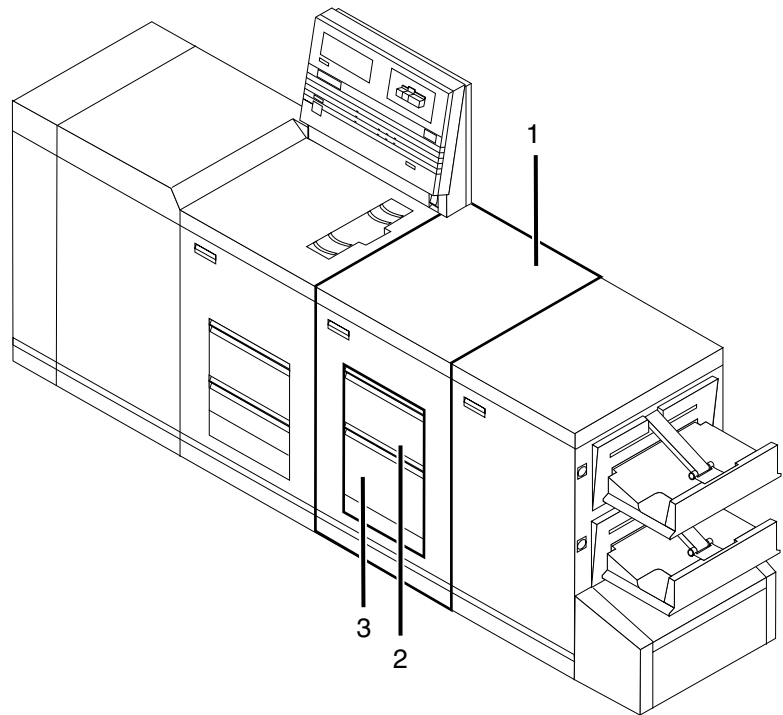

- 1 High-capacity feeder module**
- 2 Feeder tray 3**
- 3 Feeder tray 4**

Tray capacities Each high-capacity feeder tray holds 1,000 sheets of 20-pound or 80 gsm bond paper.

Paper sizes Both high-capacity feeder trays handle paper sizes from 8 by 10 inches / 203 by 254 mm to 8.5 by 14 inches / 216 by 356 mm. This includes international paper size A4 (8.27 by 11.16 inches / 210 by 283 mm).

Dual stacker

The dual stacker contains two identical output trays in which it can offset jobs or reports. Using the output configuration windows on the graphical user interface, you can send output to either or both of these trays in the desired order.

Figure 3-4. 4050/4090 with dual stacker

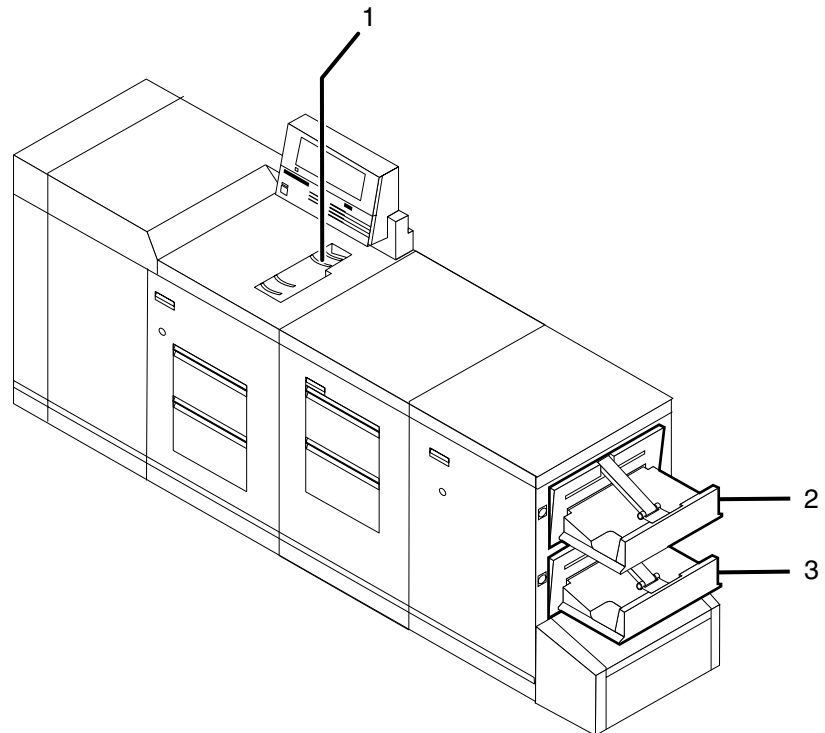

- 1 Sample tray
- 2 Stacker tray 1
- 3 Stacker tray 2

Tray capacities Stacker trays 1 and 2 each hold up to 750 sheets of 20-pound or 80 gsm bond paper.

Stitcher/stacker

The stitcher/stacker can place a wire stitch or staple in stacks of up to 50 sheets. It contains a single output tray in which it can offset jobs and reports.

Figure 3-5. 4050/4090 with stitcher/stacker

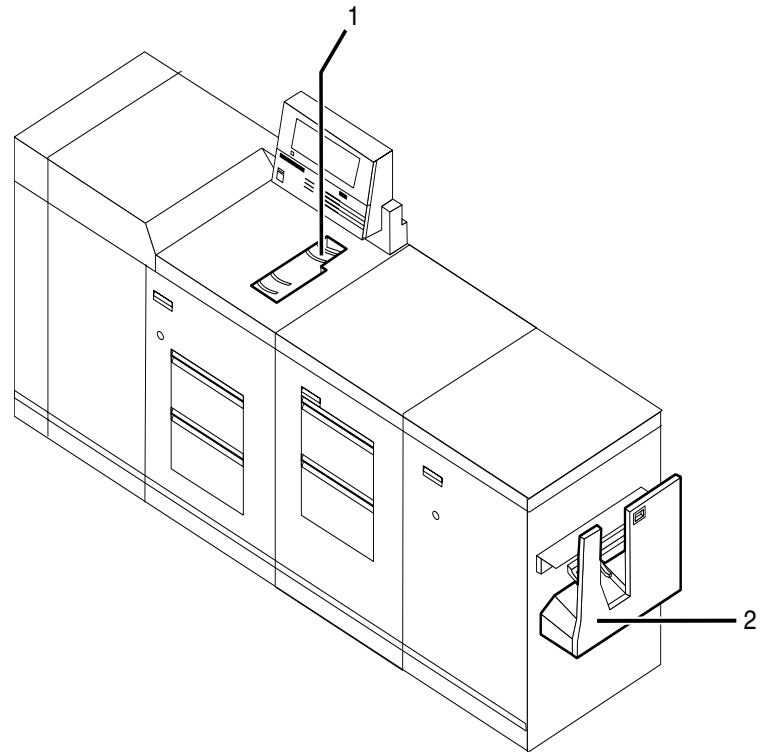

- 1 **Stitcher/stacker tray**
- 2 **Sample tray**

Tray capacities

The stitcher tray holds:

- Up to 2,000 sheets of 20-pound or 80 gsm bond, unstitched
- Up to 200 two-sheet stitched sets

Up to 50 sheets can comprise each stitched set. The wire supply provides up to 32,000 staples.

4. Preparing for installation

This chapter assists you in preparing for the installation of your Xerox DocuPrint 4050 and 4090 IPS.

Preparing for installation is a responsibility shared by personnel at your site and Xerox. Your service representatives are available to discuss installation issues and to assist you in completing the site installation tasks.

Prior to installation, you must select and prepare an appropriate location for the DocuPrint system and order supplies. This chapter helps you accomplish these tasks by providing the following information:

- A summary of your responsibilities and those of your Xerox service representative
- Connectivity requirements for setting up the IPS to receive data from the IBM host
- A checklist of installation planning activities.

For information on controller power and space requirements, refer to the “Controller specifications and requirements” chapter of this guide. For facts about printer power and space requirements, refer to the “Printer specifications and requirements” chapter of this guide.

Responsibilities

This section describes your site responsibilities and the responsibilities of your service representatives. Included are some joint responsibilities.

Xerox responsibilities

This section lists the responsibilities of the service representatives and system analysts prior to, during, and after installation:

- **Site selection**
 - Assist in site selection
 - Inspect and approve the site.
- **Installation**
 - Schedule the delivery of the hardware
 - Monitor installation activities
 - Assist you in ordering any supplies required
 - Configure system parameters

- Create default input and output configurations for your system
- Install the DocuPrint system.
- **Training**
 - Provide initial operator training
 - Provide information and assistance in registering for Xerox Customer Education classes or obtaining tutorials.
- **Service**
 - Review preventive maintenance schedules and service call procedures
 - Provide ongoing maintenance
 - Assist in resolving hardware and software problems.

Customer responsibilities

Your responsibilities prior to, during, and after installation of the IPS are to schedule and monitor your installation activities:

- **Site personnel**
 - Identify the person at your site who will be the primary interface with Xerox/Xerox Ltd.
 - Make sure the on-site primary interface is available to the service representative before and during the installation.
- **Site preparation**
 - Select and prepare the site for the IPS installation (including proper power, air conditioning, and work space).
 - Install Ethernet or Token Ring to system location.
 - Obtain the necessary interfaces, cables, transceivers, and so forth.



Note: You are responsible for obtaining, stringing, and maintaining fully-populated bus and tag cables for channel-attached systems.

- Plan and schedule installation activities.
- Convert any host-resident fonts to 300 dpi.
- For channel-attached systems: Provide your host channel address to your Xerox/Xerox Ltd. representative.
- Sysgen your host to print to an AFP Type1, Group 3 printer. Refer to your IBM documentation for further information.
- For stitcher/stacker option: Work with your service representative to determine the “low wire” percent values to be displayed on the printer control console.
- Provide a list of the stocks you want in your default input tray configuration.

- Review this *IPS Installation Planning Guide* thoroughly.
- Have the required parameters defined for configuring PSF to print on the IPS. Refer to appendix D (channel-attached) or E (TCP/IP) in this guide for examples and explanations of these parameters.
- **Training**
 - Select the personnel to undergo operator training.
 - Set up the operator training schedules.
- **Applications**
 - Work with your Xerox or Xerox Ltd. system analyst to determine requirements for the initial applications.
 - In a mixed environment, where there is a variety of printing systems, discuss print quality differences with your service representative.

Make sure that your system specialists are familiar with the operating system software specific to your IPS; operating system software is not the same for all laser printing systems. If your system specialists are familiar with one of these operating systems and you are converting to or adding another, they should be aware of the differences.

Installation planning checklist

To aid you in printer installation planning, the following is a checklist that lists the tasks that you and your service representative must complete before installation. If you have questions about any of these activities, contact your sales or service representative.

Use the time frames in this checklist as guidelines. It is best to consult your suppliers to determine the required lead times.



Note: For the purposes of the following chart, "Xerox" refers to your affiliated operating company: Xerox, Xerox Ltd., or Fuji Xerox.

Table 4-1. 4050/4090 IPS installation planning checklist

Week	Activity	Reference	Responsibility	Date completed
-4	Select location for the 4050/4090 IPS.	Chapters 5 and 6	Customer	_____
	Order additional documentation, if necessary.	Call XDSS at 1-800-327-9753; see chapter 4 (U.S. only)	Customer	_____
	Register for Xerox Customer Education classes and order tutorials, if necessary.	Appendix B	Customer and Xerox	_____
	Schedule printer delivery.		Xerox	_____
	Convert your IBM host-resident fonts to 300 dpi.		Customer	_____
-3	Schedule hardware delivery.	Sales rep.	Customer and Xerox	_____
	Prepare site:	Chapters 4, 5 and 6	Customer	_____
	• Provide a table with adequate space for hardware and cables.			_____
	• Ensure proper electrical outlets are installed.			_____
	• Install Token Ring to system location (if appropriate).			_____
	• Ensure proper operating environment.			_____
	• Obtain and string bus and tag cables (must be fully populated).			_____
• Generate the host for an AFP1 device and IPL, as required.			_____	

Table 4-1. 4050/4090 IPS installation planning checklist
(continued)

Week	Activity	Reference	Responsibility	Date completed
-2	Inspect and approve site.		Xerox	_____
	Order consumable supplies. Minimum supplies needed for installation:	Chapter 4, Appendix A and sales rep	Customer and Xerox	_____
	<ul style="list-style-type: none"> • Paper (2 cartons) • Developer (1 carton) No. 5R302 • Fuser lubricant (2 cartons) No. 8R983 • Dry ink (1carton) No. 6R301. 			
	Note: After installation, you will need to establish a procedure for ordering supplies according to your ongoing production requirements. <input type="checkbox"/>			
-1	Schedule operator training.	Systems analyst (U.S.) or site representative (non-U.S.)	Customer and Xerox	_____
	Define parameters needed to configure PSF for connectivity to the IPS printer.	Appendix D and E	Customer	_____
Install	Make sure supplies are available.	Chapter 4 and Appendix A	Customer	
	Make sure system administrators are available during software installation.		Customer	_____
	Provide host channel address and channel unit address (if printing via channel).		Customer	_____
	Provide host IP address.	Appendix D or E	Customer	_____
	Sysgen your host to print to an AFP Type 1, Group 3 printer.		Customer and Xerox	_____
	Set up Data Transfer Mode.		Customer and Xerox	_____
	Install 4050/4090 IPS printer hardware and software.		Xerox	_____
	Have operators available for training.	Appendix E	Customer	_____
	Check documentation and software kits for completeness.		Customer	_____
	Have test jobs ready to run.		Customer	_____
	Provide stocks needed for default input configuration		Customer	_____
	Provide parameters needed to configure PSF for connectivity to the IPS printer.	Appendix D or E	Customer	_____

Table 4-1. 4050/4090 IPS installation planning checklist
(continued)

Week	Activity	Reference	Responsibility	Date completed
Post-install	Become familiar with support services available.	Appendix B	Customer	_____
	Establish supplies maintenance procedure.	Appendix A	Customer	_____
	Provide ongoing 4050/4090 IPS maintenance.	<i>Guide to Performing Routine Maintenance</i>	Customer and Xerox	_____
	Order additional documentation, as necessary.	Appendix B	Customer	_____
	Adjust the IOT alignment and magnification.		Xerox	_____

Connectivity requirements

A Token Ring network or an Ethernet local area network running Transmission Control Protocol/Internet Protocol (TCP/IP) is the network communication system that may be used to transport documents from the host to the IPS. This is an alternative to the channel-attached configuration, in which data is transmitted via bus and tag cables and the HCU.



Note: The TCP/IP connectivity option is not available in a VM or VSE environment. However, a printing system with PSF/2 or PSF/6000 can attach to a PSF/VSE system and the PSF/2 or PSF/6000 can furnish the TCP/IP support for the IPS printer. □

Ethernet specifications

The Ethernet connection to the printer controller processor must be compatible with the Institute of Electrical and Electronics Engineers (IEEE) 802.3 standard.

The Ethernet interface on the processor is a 10Mb/sec twisted pair standard (10BaseT and 100BaseT). The AUI (for SuperSPARC) or the MII (for UltraSPARC) Coax Ethernet is enabled with an adapter cable.

Work with your system administrator to assess what type of network you have and what modifications need to be made to supply an Ethernet connector to the printer controller processor.

Token Ring specifications

The Token Ring connection must be compatible with the Institute of Electrical and Electronics Engineers (IEEE) 802.3 standard. The printer controller processor has a 4MB Token Ring interface.

Channel-attached specifications

For an online configuration with an IBM host system, the following cables must be available:

- Bus and tag cables (bus in, bus out, tag in, tag out)
- Emergency power off (EPO) cable (optional)
- Terminators (if necessary, due to location on channel).

For your convenience, it is possible to order the bus and tag cables for the printer through Xerox on a purchase-only basis. Contact your Xerox or Xerox Ltd. sales representative for current pricing and order information.

5. Controller specifications and requirements

This chapter provides power and space requirements for your 4050/4090 IPS printer controller. It also provides controller environmental specifications.

For facts about printer power and space requirements, refer to the “Printer specifications and requirements” chapter of this guide.

Power requirements

Your 4050/4090 IPS controller has important power requirements that must be accommodated. These requirements are summarized in the table below.

For details on printer power requirements, refer to the “Printer specifications and requirements” chapter of this guide.

Table 5-1. **4050/4090 IPS controller 60 Hz electrical requirements**

	Voltage	Amp service	KVA rating	NEMA
Sun Ultra 2 printer controller	100 to 240 VAC	15 amp	0.4 KVA	5-15R
HCU	100 to 240 VAC	15 amp	0.4 KVA	5-15R
Sun Ultra 60 printer controller	100 to 240 VAC	15 amp.	0.4 KVA	5-15R

Table 5-2. **4050/4090 IPS controller 50 Hz electrical requirements**

	Voltage	Amp. service	KVA rating
Sun Ultra 2 printer controller	100 to 240 VAC	15 amp.	0.4 KVA
HCU	100 to 240 VAC	15 amp.	0.4 KVA
Sun Ultra 60 printer controller	100 to 240 VAC	15 amp.	0.4 KVA

Agency certification: UL 478 and 1950, IEC 950, CSA 22.2 #220-1986, FCC (Class A), and VDE 0871 (Class A).

Outlet configurations

This section discusses specifications for system outlets and the required wall outlet configurations for the USA/Canada and internationally.



Note: All power outlets must be dedicated to this equipment. When determining the electrical connections for your printing system, make sure that:

- Each power cord has a separate circuit
- The printer power cord configurations match your receptacle
- Your electrical outlets are within the required specifications.

50 Hz systems: Ensure that power connections are per local codes/regulations. □

The following figure shows a 60 Hz American and Canadian wall outlet in which to plug the printer controller and HCU.

Figure 5-1. 60 Hz wall outlet

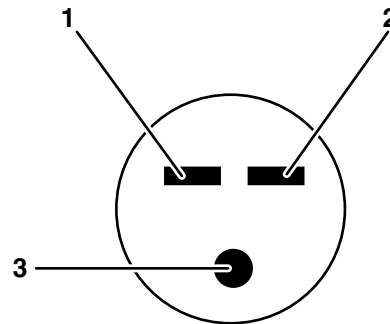

- 1 AC Hot (ACH)
- 2 AC Hot (ACH)
- 3 Earth Ground (GND)

The required American and Canadian wall outlet voltage is 100 to 120 VAC between AC hot and neutral, and between AC hot and GND. The voltage is less than three VAC between GND and neutral.

Refer to the 60 Hz and 50 Hz controller electrical requirements tables earlier in this chapter for a description of the power specifications for the controller.



Warning: To reduce the risk of electrical shock, do not plug components into any other type of power system. Contract your facilities manager or a qualified electrician if you are not sure what type of power is supplied to your work area. ⚠

Environmental specifications

Heat dissipation specifications for the 4050/4090 IPS controller are shown in the table below.

For recommended environmental ranges for the printer work area, refer to the “Printer specifications and requirements” chapter of this guide.

Table 5-3. **Heat dissipation specifications for the 4050/4090 IPS controller**

Heat dissipation	
Processor	1,100 BTU per hour
Monitor	408 BTU per hour

Space requirements

The printer controller consists of the Sun workstation and, for channel-attached systems, the HCU. This section provides recommendations for placement of controller hardware components.

For printer component space requirements, refer to the “Printer specifications and requirements” chapter of this guide. Contact your service representative if you have questions not specifically addressed in this guide.

Printer controller placement

You should consider the following factors when deciding where to place the DocuPrint printer controller:

- Adequate work space and service clearance around the equipment
- Proximity to electrical and network connectors
- Security of the work area. You may need to place the system in an area where you can restrict access to it.

The printer controller consists of the Sun workstation and, for channel-attached systems, the HCU. You must supply a table or desk as a work surface for both the printer controller and the HCU. The top of the table(s) must provide at least 36 by 36 inches / 91 by 91 cm of space for each component, to allow enough space for the components and cables, as well as for service access.

Refer to the “Printer controller specifications and requirements” summary table at the end of this chapter to make sure the tables you supply can support the weight of the printer controller hardware elements and of the HCU, and that they are suitable for the intended use.



Warning: The printer controller must be positioned within the line-of-sight of the printer for safety purposes while servicing the equipment. 



Caution: Position the table(s) at least 6 inches / 15.2 cm from the wall. Make sure the workstation processor and the HCU are at least 12 inches / 30.4 cm from the wall. Do not put the processor or the HCU on the IPS printer.

Sun Ultra 2 workstation placement

Following are guidelines for placement of the Sun Ultra 2 workstation components of the printer controller.

Figure 5-2. Sun Ultra 2 printer controller hardware

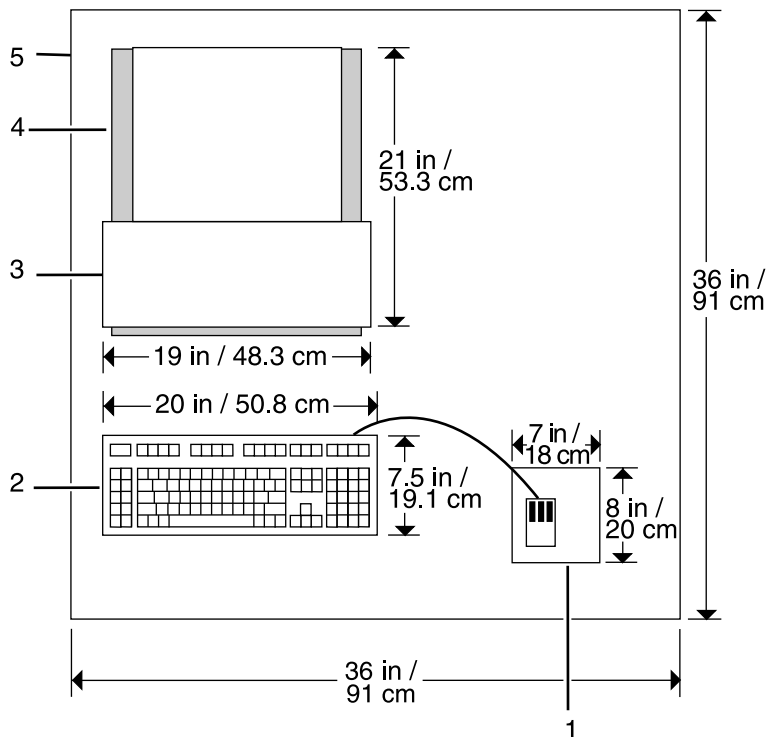

- 1 Mouse and mouse pad
- 2 Keyboard
- 3 Monitor
- 4 Processor
- 5 Table

When you place your workstation processor on a table top, make sure to allow at least 6 inches / 152 mm of unobstructed space at the rear and both sides of the processor. Do not allow any piece of equipment to blow warm air into the air-intake vents of the processor.



Caution: Do not place a monitor with a base larger than the processor on top of the unit. Do not block any fan or vents on the sides or rear of the processor.

Sun Ultra 60 workstation placement

Following are guidelines for placement of the Sun Ultra 60 workstation components of the printer controller.

Figure 5-3. **Sun Ultra 60 printer controller hardware**

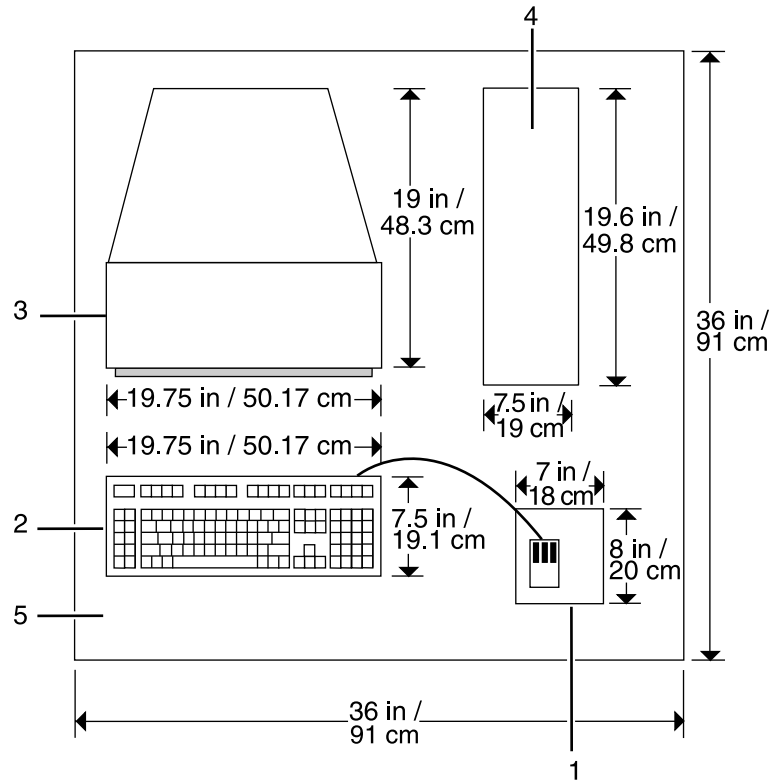

- 1 **Mouse and mouse pad**
- 2 **Keyboard**
- 3 **Monitor**
- 4 **Processor**
- 5 **Table**

To ensure consistent performance and avoid any damage to equipment, follow these rules for placing the components of the Sun Ultra 60 controller.

Do:

- Place the monitor and processor on a desk or table top, separate from the printer. The monitor should be placed beside the processor, on the same surface. (The cartridge tape drive may be placed on top of the processor.)
- Keep the processor in an upright, vertical position as illustrated below.
- Allow at least 6 inches / 152 mm of unobstructed space at the front and rear of the processor, so the fan and vents are not blocked.

The following illustration shows fan and vent locations on the front and back of the controller.

Figure 5-4. Sun Ultra 60 fan and vent locations to keep clear

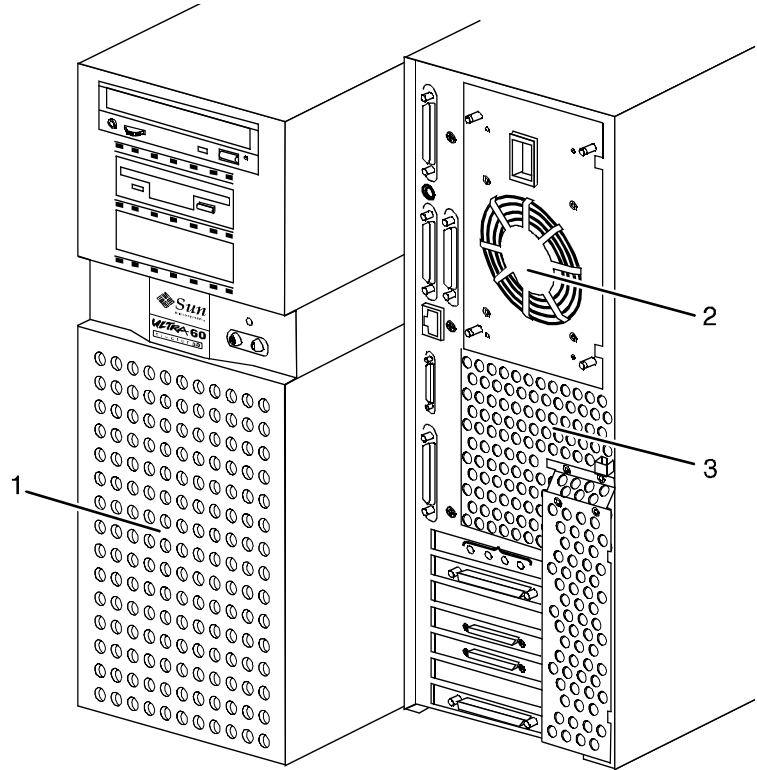

- 1 Vent in front of processor**
- 2 Fan in back of processor**
- 3 Vent in back of processor**

Do not:

- Do not place the controller monitor on top of the processor.
- Do not allow any piece of equipment to blow warm air into the air intake vents of the processor.
- Do not place the processor on its side, or in any other position but the upright, vertical position shown in the previous figure.
- Do not place the processor or monitor on top of the printer.

HCU placement (channel-attached systems only)

The following shows the recommended HCU hardware placement, for channel-attached systems.

Figure 5-5. **IPS HCU hardware (for channel-attached systems)**

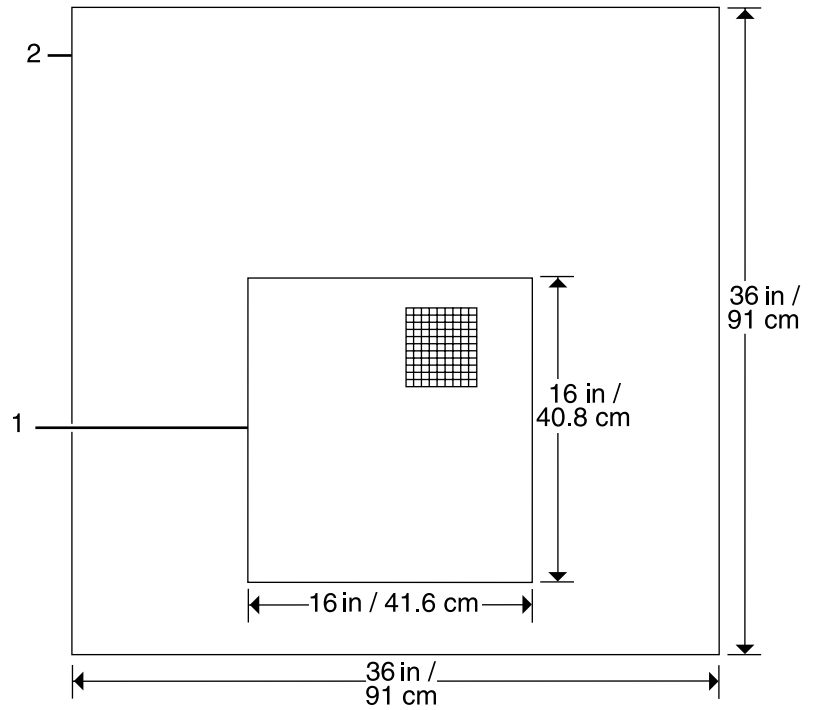

- 1 HCU
- 2 Table

Controller hardware specifications and requirements summary

The following table summarizes the specifications and electrical requirements of your DocuPrint IPS printer controller hardware components.

For a summary of printer hardware specifications and requirements, refer to the "Printer specifications and requirements" chapter of this guide. Contact your service representative if you have questions not specifically addressed in this guide.

Table 5-4. **Printer controller specifications and power requirements**

Device	Dimensions (depth, width, height)	Weight	Heat dissipation	Power requirements	Cable lengths
Host Channel Unit (HCU) (channel-attached systems only)	d=15 in. / 40.8 cm h=5 in. / 12.6 cm w= 16 in. / 41.6 cm	26 lbs. 10 oz. / 12.4 kgs	N/A	120 VAC within 6 feet; 120 volt at 2 amps or 240 volt at 1 amp	Bus and tag cables must conform to host system requirements (200 to 400 ft. / 66.7 to 133.3 m) and accommodate system setup.
Processor	d=16.1 / 40.9 cm w=16.4 / 41.7 cm h= 3 in. / 7.6 cm	27 lbs. / 12.7 kgs	1,100 BTU per hours	Sun Ultra 2 (60 Hz): 100 to 240 VAC, 15 amp, 0.4 KVA, 5-15 NEMA Sun Ultra 2 (50 Hz): 100 to 240 VAC, 15 amp, 0.4 KVA Sun Ultra 60 (60 Hz): 100 to 240 VAC, 15 amp, 0.4 KVA, 5-15 NEMA Sun Ultra 60 (50 Hz): 100 to 240 VAC, 15 amp, 0.4 KVA	Power: 8 ft. / 2.4 m Interface to printer: 20 ft. / 6.1 m usable length
Monitor	d=6.1 / 41cm w=18.1 / 46 cm h=17.7 in. / 45 cm	61 lbs. / 27.7 kg	408 BTU per hour	100-120 ~ VAC, 1 phase, 50-60 Hz, 3.0A, 0.4 KVA 200-240 ~ VAC, 1 phase, 50-60 Hz, 2.0A, 0.4 KVA	Video cable to processor: 46 in. / 1.17 m
4 mm cartridge tape drive	d=12.2 in. / 31 cm w=7.5 in. / 19 cm h=2.8 in. / 7 cm	8 lbs. / 6.6 kg	---	100-120/200-240 VAC, 0.8/0.4A, 47-63 Hz	SCSI cable to processor or additional SCSI device: 28 in. / 71 cm

Table 5-4. **Printer controller specifications and power requirements** (continued)

Device	Dimensions (depth, width, height)	Weight	Heat dissipation	Power requirements	Cable lengths
Keyboard	d =7.5 in. / 17.8 cm w =18 in. / 45.7 cm	2 lbs. / 1 kg	---	---	72 in. / 1.8 m
Mouse	d =3 in. / 8 cm w =4 / 10 cm h =2 in. / 5 cm	0.3 lbs. / 0.14 kg	---	---	25 in. / 63 cm

6. Printer specifications and requirements

This chapter provides power and space requirements for your 4050/4090 printer. It also provides printer environmental specifications.

For facts about controller power and space requirements, refer to the “Controller specifications and requirements” chapter of this guide.

Power requirements

Your DocuPrint system has important power requirements that must be accommodated. These requirements are summarized in the table below. For further details on power requirements, refer to the voltage charts and wiring diagrams that follow.

For details on controller power requirements, refer to the “Controller specifications and requirements” chapter of this guide.

Table 6-1. 4050 printer 60 Hz electrical requirements

Voltage	Amp. service	KVA rating	NEMA
120/208 or 120/240 VAC	30 amp	Operating: 4.1 Standby: 2.7	14-30R

Table 6-2. 4050 printer 50 Hz DELTA electrical requirements

Voltage	Amp. service	KVA rating
220, 230, 240 VAC (3 phase, 4 wire or single-phase)	30 amp	Operating: 3.8 Standby: 2.5

Table 6-3. 4090 printer 60 Hz electrical requirements

Voltage	Amp. service	KVA rating	NEMA
120/208 or 120/240 VAC	30 amp	Operating: 5.5	14-30R

Table 6-4. 4090 printer 50 Hz DELTA electrical requirements

Voltage	Amp. service	KVA rating
220, 230, 240 VAC	30 amp	Operating: 5.5

Agency certification: UL 478 and 1950, IEC 950, CSA 22.2 #220-1986, FCC (Class A), and VDE 0871 (Class A).

Outlet configurations

This section discusses specifications for the DocuPrint system outlets and the required wall outlet configurations for the U. S. / Canada and internationally.



Note: All power outlets must be dedicated to this equipment. When determining the electrical connections for your system, make sure that:

- Each power cord has a separate circuit
- The printer power cord configurations match your receptacle
- Your electrical outlets are within the required specifications.

50 Hz systems: Ensure that power connections are per local codes/regulations. □

Printer outlet voltages—60 Hz

The following table shows the voltages for the outlets on your printing system. All power outlets must have a dedicated circuit for each system equipment piece.

Table 6-5. **60 Hz voltage requirements at power outlet**

Measurement of wiring	Nominal	Range
Line 1 to neutral	120 V	105 to 127 V
Line 2 to neutral	120 V	105 to 127 V
Neutral to ground	0 V	0 to 10 V
Line 1 to line 2	208 V	181 to 220 V
Line 1 to ground	120 V	105 to 127 V
Line 2 to ground	120V	105 to 127 V

Printer power cord configurations

The following figure shows the 60 Hz power cord configuration for 30 amp NEMA 14-30R. Voltage to ground is shown for troubleshooting purposes.

Figure 6-1. **60 Hz power configuration**

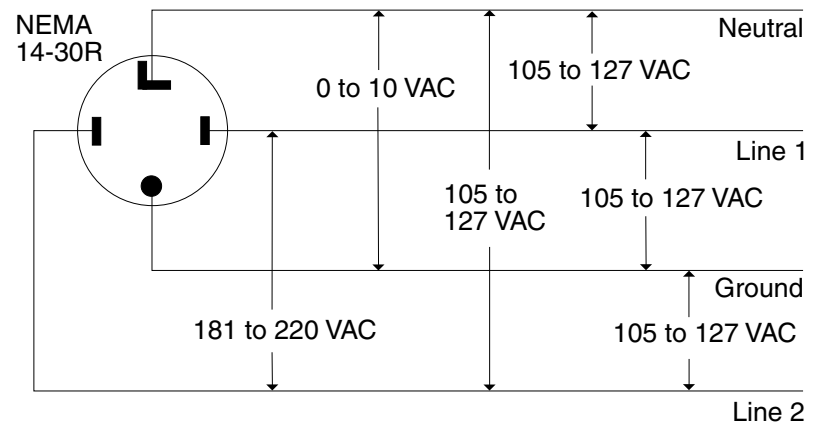

Printer outlet voltages—50 Hz

All power outlets must have a dedicated circuit for each system equipment piece. Make sure each power cord has a separate circuit.

50 Hz systems: Ensure that power connections are per local codes/regulations.

Single phase DELTA configurations

For 50 Hz DELTA configurations, measure the DELTA connection voltages at the power source.

Table 6-6. **50 Hz single phase DELTA outlet voltage requirements**

Wiring	Nominal	Range
Line to neutral	220 VAC 230 VAC 240 VAC	198-242 VAC 207-253 VAC 216-264 VAC
Neutral to ground	0 VAC	<10 VAC

Three-phase DELTA configurations

The current carrying conductors available for 50 Hz, three-phase, DELTA are:

- Three-phase
- Safety ground.

Table 6-7. **50 Hz three-phase DELTA outlet voltage requirements**

Nominal	Phase to phase
220 VAC	198-242 VAC
230 VAC	207-253 VAC
240 VAC	216-264 VAC



Note: If one of the phases is connected to ground in the service system, it should be connected to the neutral terminal of the printer. In this case, the line is not a true neutral, and voltage between all current carrying conductors is equal and mutually 120 degrees out of phase. □

Environmental specifications

When you select a site location for your DocuPrint printer, avoid environments with extreme variations in temperature and other hazards, such as excessive dust or humidity. Recommended environmental ranges for the work area are as follows:

Table 6-8. **Environmental specifications for 4050/4090**

Condition	Range	
Temperature:	Recommended:	72° F ± 4° F 22° C ± 2° C
	Minimum:	60° F / 15.5 °C
	Maximum:	80° F / 26.7° C
Humidity:	Recommended:	45% ±10%
	Minimum:	30%
	Maximum:	65%
Altitude:	Normal:	Up to 6,000 feet / 1,830 m above sea level
	Maximum:	9,000 feet / 2,743 m above sea level.
4050 Printer - 60 Hz heat dissipation	Operating:	11,200 BTU/hour
	Standby:	7,400 BTU/hour
4050 Printer - 50 Hz DELTA heat dissipation:	Operating:	11,200 BTU/hour
	Standby:	7,400 BTU/hour
4090 Printer - 60 Hz heat dissipation:	Operating:	14,980 BTU/hour
	Standby:	9,100 BTU/hour
4090 Printer - 50 Hz DELTA heat dissipation:	Operating:	14,980 BTU/hour
	Standby:	9,100 BTU/hour

Space requirements

You should consider the following factors when deciding where to place the printer hardware components:

- Adequate work space and service clearance around the equipment
- Proximity to electrical and network connectors
- Security of the work area. You may need to place the system in an area where you can restrict access to it. This may be important if your personnel need to print confidential documents or if you are concerned with unauthorized usage.

Dimensions and weights of the printer components are listed in this section, along with diagrams, to help you visualize the sizes and total space requirements.



Warning: The printer controller must be positioned within the line-of-sight of the printer for safety purposes while servicing the equipment.



Note: There must be a 78-inch / 198-cm vertical clearance throughout the entire area. In addition, your printer must be installed in a fixed location with a minimum clearance space of 36 inches / 91.4 cm around all sides of each piece of equipment for access by service personnel.

For information on clearance space and other space planning considerations, refer to the “Space planning guidelines” section of this chapter. Contact your service representative if you have questions not specifically addressed in this guide.

Printer placement

The following configurations are available for your Xerox DocuPrint 4050/4090 printer:

- Standard (two-tray) feeder with dual stacker
- Standard (two-tray) feeder with stitcher/stacker
- High-capacity feeder (HCF) with dual stacker
- High-capacity feeder with stitcher/stacker.

Printer with standard (two-tray) feeder and dual stacker

The dimensions of the printer with the standard (two-tray) feeder and the dual stacker are as follows:

Dimension	Specifications
Width:	91.5 inches / 232 cm
Depth:	34.5 inches / 87.6 cm
Height:	41 inches / 104 cm
Total weight:	1,272 pounds / 578 kg
Total space requirement:	163.5 by 106.5 inches / 415 by 271 cm

The following illustrates a top view of the space requirements for the printer with a standard (two-tray) feeder and dual stacker configuration.

Figure 6-2. 4050/4090 printer with dual stacker

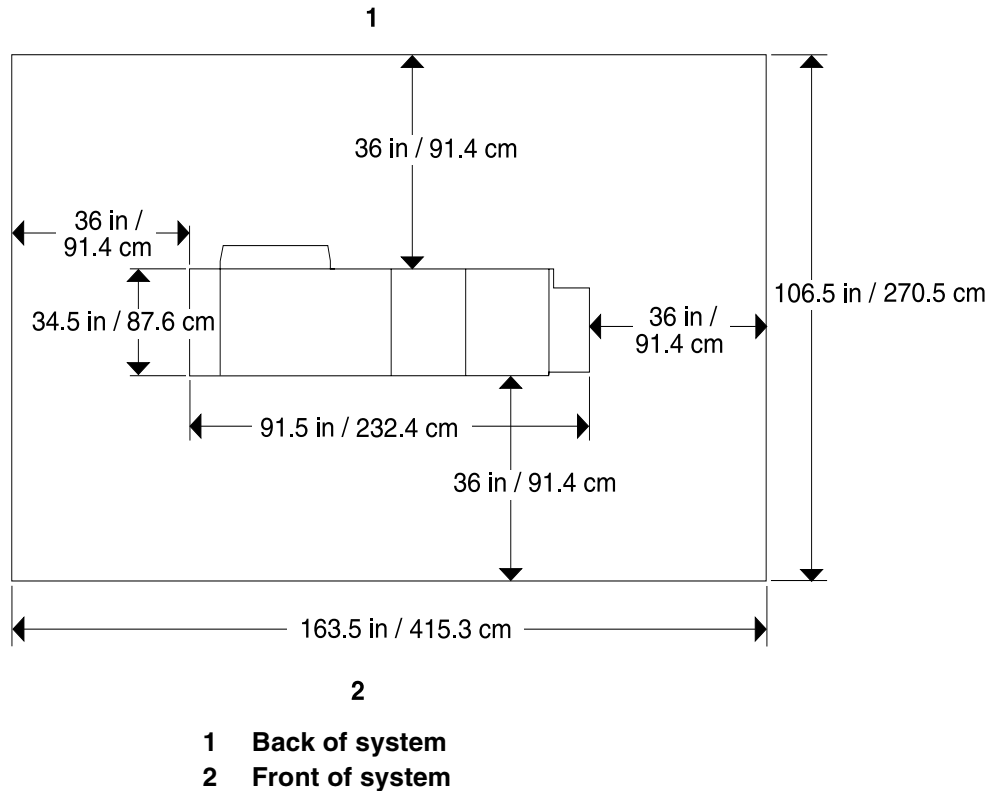

- 1 Back of system
- 2 Front of system

Printer with standard (two-tray) feeder and stitcher/stacker

The dimensions of the printer with the standard (two-tray) feeder and the stitcher/stacker are as follows:

Dimension	Specifications
Width:	89.5 inches / 227 cm
Depth:	34.5 inches / 87.6 cm
Height:	41 inches / 104 cm
Total weight:	1,274 pounds / 578 kg
Total space requirement:	161.5 inches by 106.5 inches / 410 cm by 271 cm

The following illustrates a top view of the space requirements for the printer with a standard (two-tray) feeder and stitcher/stacker configuration.

Figure 6-3. 4050/4090 printer with stitcher/stacker

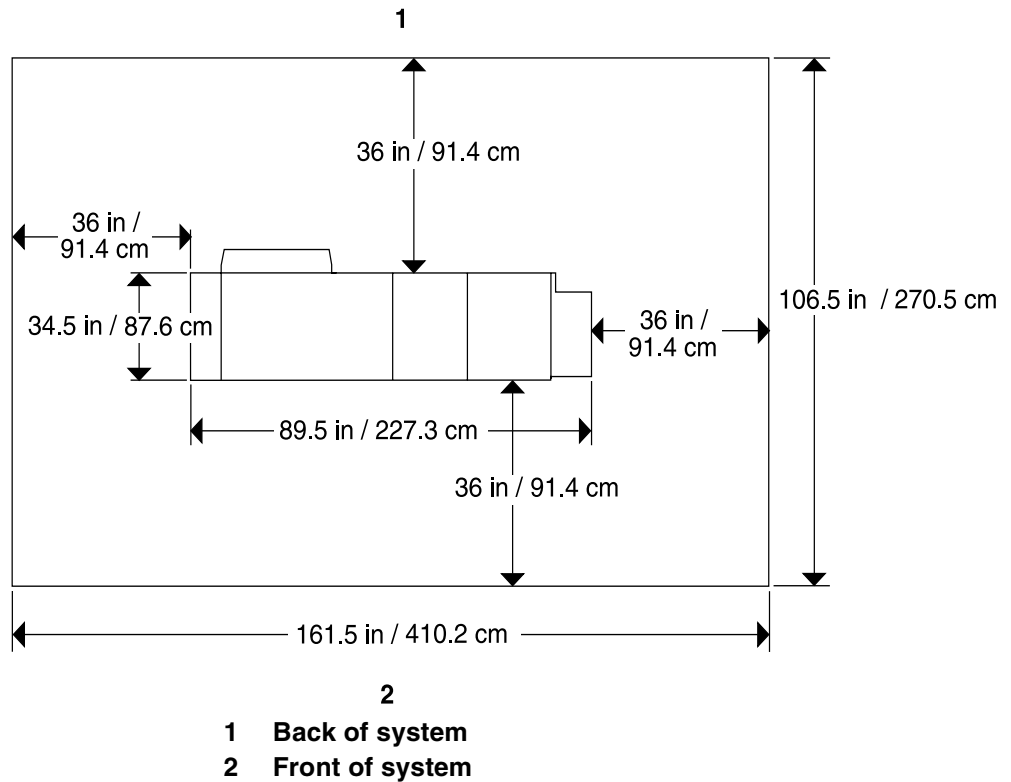

Printer with high-capacity feeder and dual stacker

The dimensions of the printer with the high-capacity feeder and the dual stacker are as follows:

Dimension	Specifications
Width:	114 inches / 290 cm
Depth:	34.5 inches / 87.6 cm
Height:	41 inches / 104 cm
Total weight:	1,560 pounds / 709 kg
Total space requirement:	186 inches by 106.5 inches / 472 cm by 271 cm

The following illustrates a top view of the space requirements for the printer with a high-capacity feeder and dual stacker configuration. The high-capacity feeder provides the printer with additional paper handling capabilities.

Figure 6-4. **4050/4090 printer with high-capacity feeder and dual stacker**

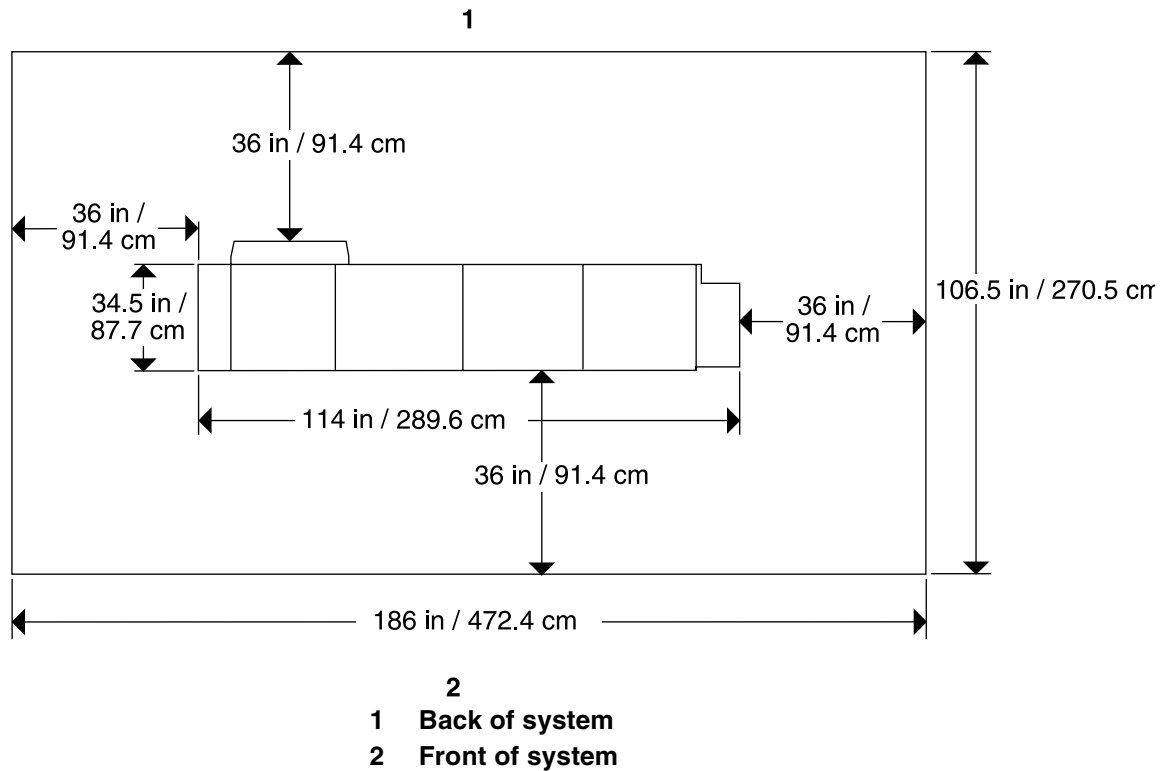

Printer with high-capacity feeder and stitcher/stacker

The dimensions of the printer with the high-capacity feeder and the stitcher/stacker are as follows:

Dimension	Specifications
Width:	112 inches / 285 cm
Depth:	34.5 inches / 88 cm
Height:	41 inches / 104 cm
Total weight:	1,562 pounds / 710 kg
Total space requirement:	184 inches by 106.5 inches / 467 cm by 271 cm

The following illustrates a top view of the space requirements for the printer with a high-capacity feeder and stitcher/stacker configuration.

Figure 6-5. **4050/4090 printer with high-capacity feeder and stitcher/stacker**

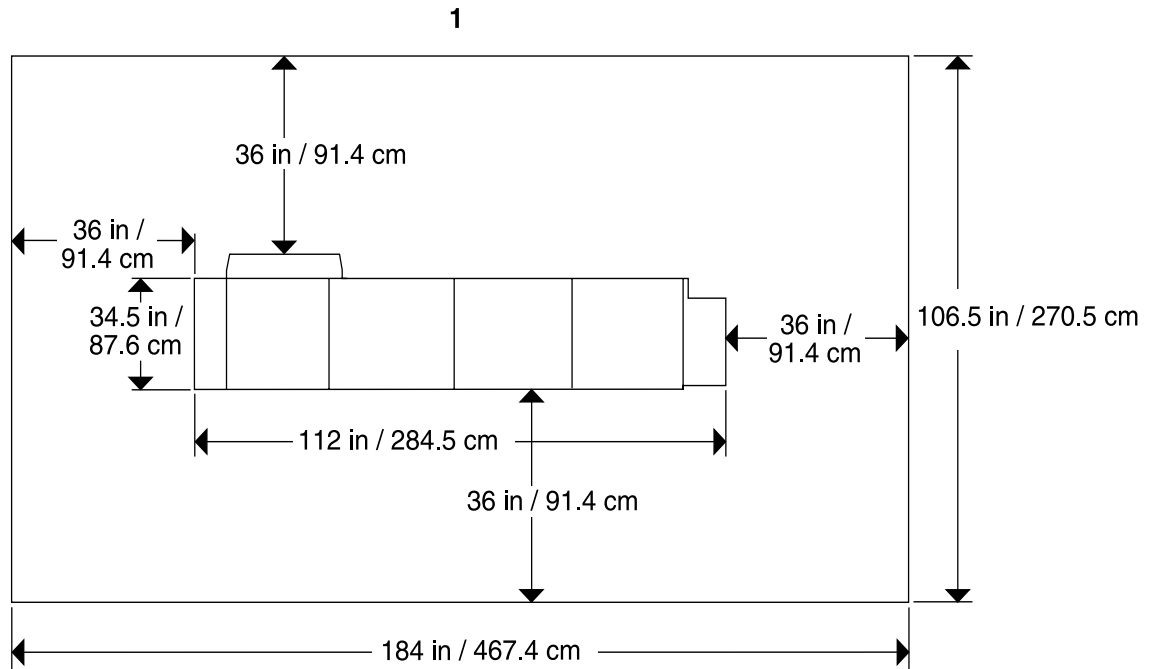

- 1 Back of system
- 2 Front of system

Space planning guidelines

When determining your space requirements and planning for shared space between your DocuPrint printers, it is important to consider all of the components you plan to install.

To ensure all of the space requirements are met, it is important to work with your Xerox representative.

Before installation, you must consider the following:

- Clearance space requirements where you intend to install the printing system
- Delivery access requirements
- Recommended cable lengths and locations (refer to the “System connections” chapter of this guide for more information)
- Floor leveling.

Clearance space requirements

The printer must be installed in a fixed location that provides the following clearance space:

- 36 inches / 91.4 cm on all sides of each component
- 78 inches / 198 cm of vertical clearance throughout the entire area
- 24 inches / 61 cm of exclusive operator area in front of each component.

Shared space

It is best to provide the full amount of clearance space around the hardware components. Your environment may require you to use shared space between components, such as between the printer and another Xerox printing system. You can share the 36-inch / 91.4 cm clearance space around each component, as long as you follow these rules:

- Space may be shared only with other Xerox equipment.
- Components may share the 36-inch / 91.4 cm general service clearance areas, but they may not share the 24-inch / 61 cm operator area in front of each component.
- There must be 78 inches / 198 cm of vertical clearance throughout the entire area.



Note: Finishers attached to your bypass transport may occupy shared space with Xerox equipment. However, they must be removable to allow servicing of the DocuPrint NPS printer stackers. Consult with your Xerox representatives to ensure all the requirements are met.

The following figures illustrate three possible configurations of shared space.

Back-to-back shared space

The figure below illustrates the two printers placed in a back-to-back position. This allows them to share the entire 36 inches / 91.4 cm of general service space.

Figure 6-6. **Back-to-back shared service area space**

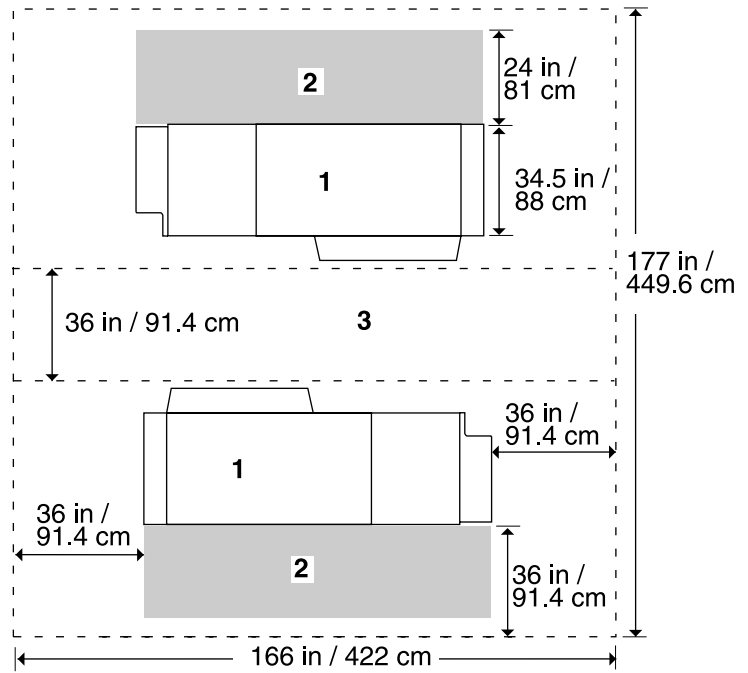

- 1 Printer
- 2 Operator area
- 3 General service area

Face-to-back shared space The following figure shows the two printers arranged with one facing the back of the other. Between them is 60 inches / 152.4 cm of space. This allows for 24 inches / 61 cm of operator space in front of the printer facing *toward* the other, plus 36 inches / 91.4 cm of service space behind the printer facing *away from* the other.

Figure 6-8. **Face-to-back shared service area space**

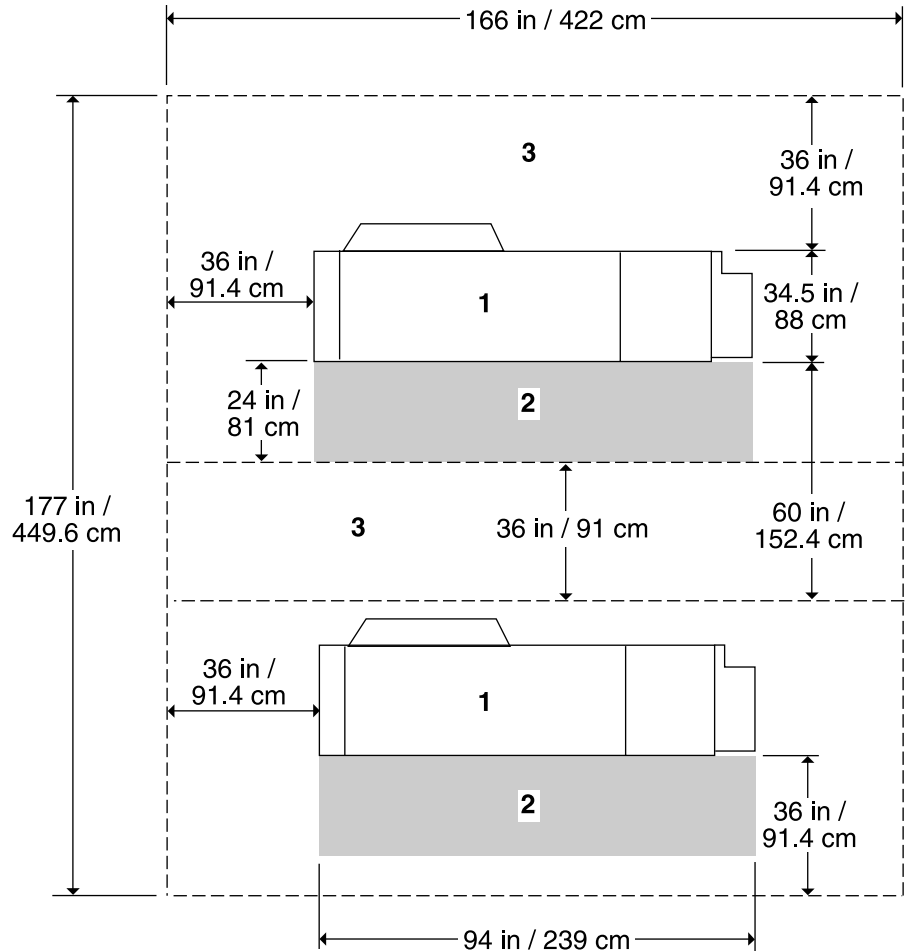

- 1 Printer**
- 2 Operator area**
- 3 General service area**

Floor leveling

For proper operation, the printer must be perfectly level. On floors less than two degrees out of level, installation personnel use a leveling kit to level the machine.



Note: The printer will not function properly on floors more than two degrees out of level. □

If the floor is more than two degrees out of level, this condition cannot be corrected by the leveling kit. Another suitable location must be found for the printer to be installed properly.

For your reference, two degrees represents a height discrepancy of approximately 3.8 inches / 9.6 cm measured at the casters with the printer tilting from left to right, or approximately 0.7 inches / 1.8 cm with the printer tilting from back to front.

If you move the printer unit after its initial installation, it is your responsibility to make sure that the printer can be leveled properly. If you do not have the leveling kit (the printer in its initial location did not require it), and you need one to level the printer in a new location, contact your Xerox site representative to obtain one.

Delivery access requirements

It is easy to overlook the path required to move the equipment from the truck to the operation site. To determine access, ask the following questions:

- Does the equipment need to go up stairs?
- Do you have an elevator, if the equipment is to be located above the first floor?
- Is the elevator large enough for the equipment?
- How wide are the hallways and doorways?
- Do you have a loading dock or a specific door to which the equipment should be delivered?

You need to review these issues prior to, or at the time of, the site inspection conducted by your service representative.

The equipment dimensions are specified earlier in this chapter, so it is easy to determine whether your hallways and doorways are wide enough to permit access.

Turning radius

You must also consider the width of the passageway when the equipment must negotiate a corner, whether into a room, an elevator, or another passageway.

There are L-shaped turns and T-shaped turns. The diagrams and the tables that follow show the minimum space required to maneuver through the turns.

Figure 6-9. **T-shaped turn**

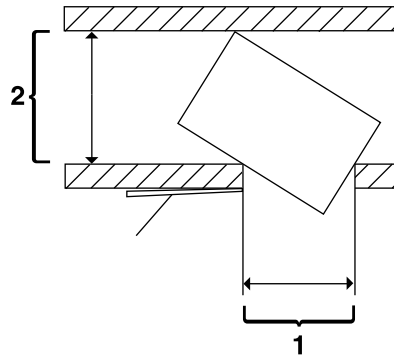

- 1 **Passage A**
- 2 **Passage B**

Figure 6-10. **L-shaped turn**

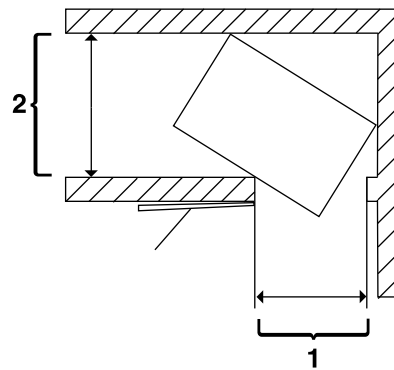

- 1 **Passage A**
- 2 **Passage B**

Using the turning radius table

To use the following table:

1. Measure the minimum width of the passage or doorway you need to use. This is Passage A.
2. Find that number (or the next higher number) in the turning radius table and read across to the corresponding minimum value for Passage B, depending on the type of turn the equipment must negotiate.

The following table contains turning requirements for the printer.

Table 6-9. **Turning radius for the printer**

If passage or doorway A is:	Passage B for an L-turn must be:	Passage B for a T-turn must be:
29 inches / 73.7 cm	68.6 inches / 174.2 cm	67.6 inches / 171.7 cm
30 inches / 76.2 cm	66.2 inches / 168.1 cm	65.7 inches / 166.9 cm
31 inches / 78.7 cm	64.2 inches / 163.1 cm	63.9 inches / 162.3 cm
32 inches / 81.3 cm	62.3 inches / 158.2 cm	62.2 inches / 158 cm
33 inches / 83.8 cm	60.7 inches / 154.2 cm	60.6 inches / 153.9 cm
34 inches / 86.4 cm	59.1 inches / 150.1 cm	59.1 inches / 150 cm
35 inches / 88.9 cm	57.7 inches / 146.6 cm	57.7 inches / 146.6 cm
36 inches / 91.4 cm	56.3 inches / 143 cm	56.3 inches / 143 cm
37 inches / 94 cm	55.2 inches / 140.2 cm	55.2 inches / 140.2 cm
38 inches / 96.5 cm	54.0 inches / 137.2 cm	54.0 inches / 137.2 cm
39 inches / 99.1 cm	52.9 inches / 134.4 cm	52.9 inches / 134.4 cm
40 inches / 101.6 cm	51.8 inches / 131.6 cm	51.8 inches / 131.6 cm
41 inches / 104.1 cm	50.5 inches / 128.3 cm	50.5 inches / 128.3 cm
42 inches / 106.7 cm	49.8 inches / 126.5 cm	49.8 inches / 126.5 cm

Printer hardware specifications and requirements summary

The following table summarizes the specifications and electrical requirements of your printer hardware components.

For a summary of controller hardware specifications and requirements, refer to the “Controller specifications and requirements” chapter of this guide. Contact your service representative if you have questions not specifically addressed in this guide.

Table 6-10. **Printer specifications and power requirements—4050/4090 printer**

Device	Dimensions (depth, width, height)	Weight	Heat dissipation	Power requirements
4050/4090 printer: Standard (two-tray) feeder and dual stacker	d=34.5 in. / 87.6 cm w=91.5 in. / 232 cm h=41 in. / 104 cm Total space required: 163.5 by 106.5 in. / 415 by 271 cm	1,272 lbs. / 578 kg	4050 (60 Hz) and 4050 (50 Hz DELTA): Operating: 11,200 BTU per hour Standby: 7,400 BTU per hour 4090 (60 Hz) and 4090 (50 Hz DELTA): Operating: 14,980 BTU per hour Standby: 9,100 BTU per hour	4050 (60 Hz): 120/208 VAC or 120/240 VAC, 30 amp Oper. max: 4.1 KVA Standby: 2.7 KVA NEMA 14-30R 4050 (50 Hz DELTA): 200, 230, 240 VAC (3-phase, 4 wire or single-phase), 30 amp Oper. max: 3.8 KVA Standby: 2.5 KVA 4090 (60 Hz) and 4090 (50 Hz DELTA): Oper. max: 5.5 KVA
4050/4090 printer: Standard (two-tray) feeder and stitcher/stacker	d=34.5 in. / 87.6 cm w=89.5 in. / 227 cm h=41 in. / 104 cm Total space required: 161.5 by 106.5 in. / 410 by 271 cm	1,274 lbs. / 579 kg	Same as 4050/4090 standard (two-tray) feeder and dual stacker configuration, above.	Same as 4050/4090 standard (two-tray) feeder and dual stacker configuration, above.
4050/4090 printer: High-capacity feeder and dual stacker	d=34.5 in. / 87.6 cm w=114 in. / 290 cm h=41 in. / 104 cm Total space required: 184 by 106.5 in. / 467 by 271 cm	1,560 lbs. / 709 kg	Same as 4050/4090 standard (two-tray) feeder and dual stacker configuration, above.	Same as 4050/4090 standard (two-tray) feeder and dual stacker configuration, above.

Table 6-10. **Printer specifications and power requirements—
4050/4090 printer** (continued)

Device	Dimensions (depth, width, height)	Weight	Heat dissipation	Power requirements
<p>4050/4090 printer: High-capacity feeder and stitcher/stacker</p>	<p>d=34.5 in. / 87.6 cm w=112 in. / 285 cm h=41 in. / 104 cm</p> <p>Total space required: 184 by 112.5 in. / 467 by 286 cm</p>	<p>1,562 lbs. / 710 kg</p>	<p>Same as 4050/4090 standard (two-tray) feeder and dual stacker configuration, above.</p>	<p>Same as 4050/4090 standard (two-tray) feeder and dual stacker configuration, above.</p>

Space planning templates

The dimensions and space requirements for your printer components are provided earlier in this chapter. The space planning templates are designed to simplify the space planning process by helping you to create a floor plan for your base components, particularly if you have shared clearance space.

The easiest way to use the space planning templates is to move the templates around on the grid located at the end of this section and determine the optimum placement for your printer components. Make sure to consider other pieces of equipment, such as cabinets, tables, and optional equipment when planning your space. Your customer support representative can help you plan space for additional components.

The templates are to scale with the grid; each square is equal to 12 by 12 inches/30.5 by 30.5 cm. The curved dotted lines in the corners of the space perimeters indicate the corners that may be rounded off while still maintaining the required clearance space.

There are a number of factors to keep in mind when planning your site, including the following:

- Clearance space requirements
- Cable length.

Refer to these sections in this manual when considering the various factors involved in planning the appropriate location for your printing system.

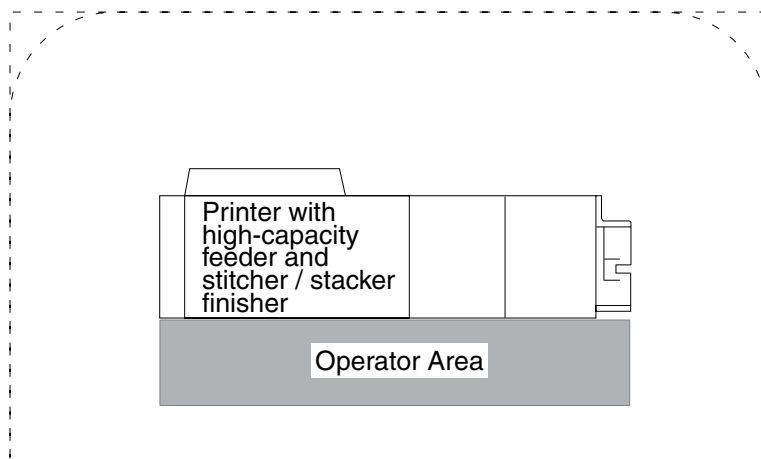
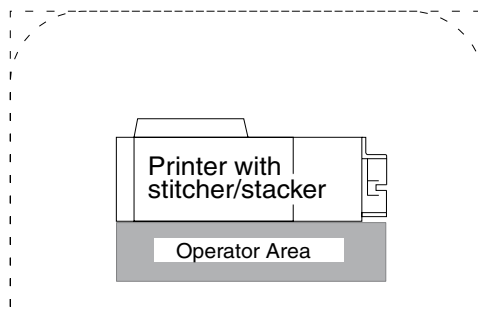
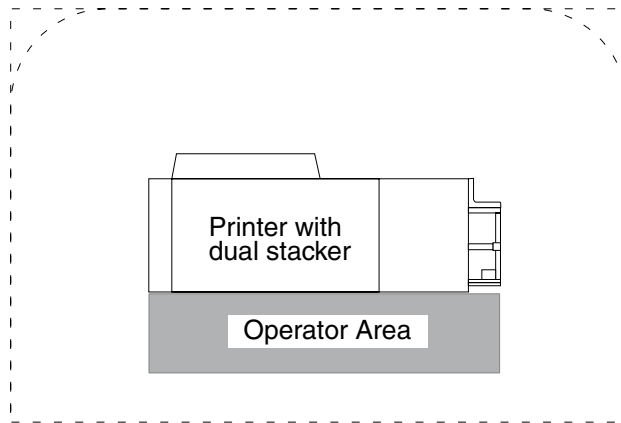

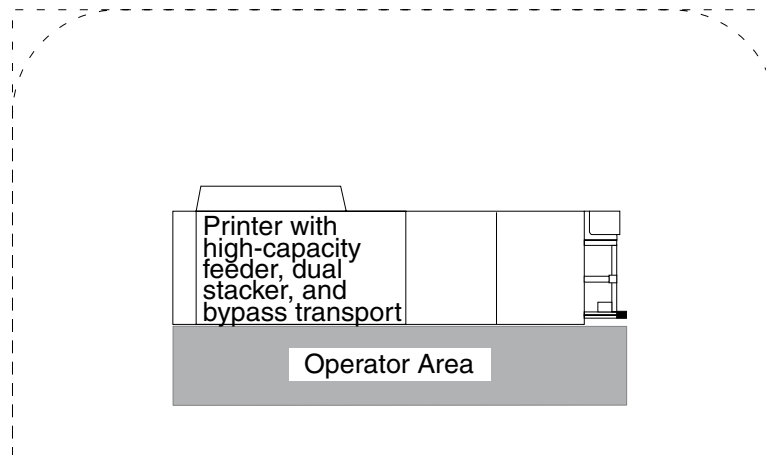
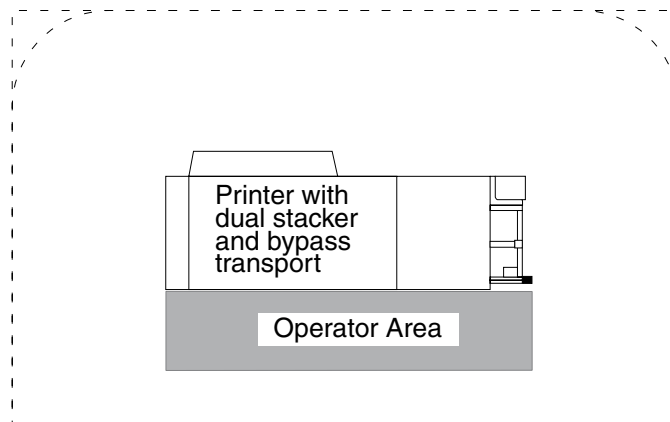
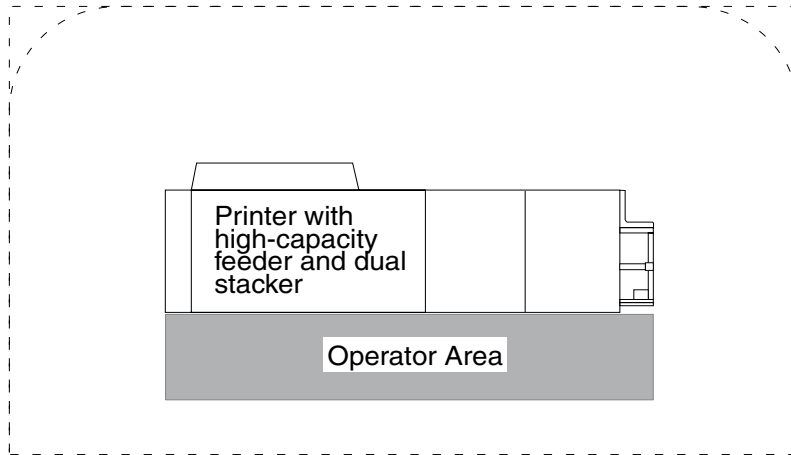

7. System connections

This chapter provides cable requirements for your 4050/4090 IPS system. It also provides information about channel-attaching your IPS printer. To ensure all of your cable requirements are met, it is important to work with your Xerox representative.

Cable lengths

Cable lengths are important considerations in planning your layout, as components can be separated only up to the length of the data interface cables that connect them.

Cables supplied with the printer are of sufficient length to meet the needs of most installations. Some of these cables are specific lengths to conform to engineering and safety standards.

Data cables The printer components can be separated up to the length of the data interface cables that connect them. The printer and controller are connected by a 25-foot / 7.5 meter data cable.

Power cables The 4050/4090 power cable lengths are as follows:

Table 7-1. **Power cable lengths**

Power cable	Length
Printer controller	8 feet / 2.4 meters
Printer	10 feet / 3 meters



Warning: Using an inappropriate alternate cable may degrade the performance of your equipment and may also be hazardous. ⚠



Note: Cable length loss must be factored in if equipment is installed in a raised-floor environment. You should also consider that part of the length of a cable is routed inside the equipment to connect with interior power or data receptacles. □

Cable locations

To run the cables beneath the flooring effectively, it is necessary to know where the cables enter and exit the printer. The following diagrams show those locations (marked with an X).

All power cords attach to the back of the printer. Listed below are the distances of the printer power cord attachments from the left end of the printer as you face it.

Figure 7-1. 4050/4090 cable enter/exit location (top view)

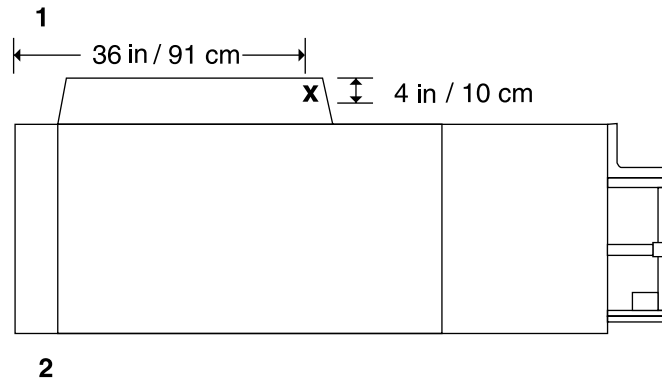

- 1 Back of system
2 Front of system

Channel attachments

The IPS printing system conforms to IBM standards and requirements for any channel-attached printer. When you channel-attach your printer, keep the following in mind:

- Channel length is usually determined by the length of the cables, the number of devices on the channel, and the number of connections in the cable itself (for example, connecting two cables to each other).
- Subtract 15 feet from the total allowable cable length for any device attached to the channel or for any connection of two cables.
- IBM channel cable lengths are as follows:
 - Gray: 200 feet / 61 m (with one device, 185 feet / 56 m)
 - Blue: 400 feet / 122 m (with one device, 385 feet / 117 m)

For further information regarding IBM channel connections, refer to the following IBM manuals:

- *IBM System 360 and System 370 Input-output Interface Channel to Control Unit OEM Information* (#GA22-6974-3825)
- *Page Printer Product Description* (#G544-3482)
- *3825 Introduction and Planning Guide* (#G544-3480).

This chapter describes the activities performed by you and Xerox during the installation of the Xerox DocuPrint 4050 or 4090 IPS hardware and software components. Before installation can begin, you must complete the tasks described in the “Preparing for installation” chapter of this guide.

Installation process

Xerox is responsible for the physical installation of the 4050/4090 IPS hardware components and the software.

For customers outside the United States, contact your local Xerox representative or operating company for your specific installation process.

The installation process can take one or several days to complete. Equipment, software kits, and documentation kits may all arrive in one day, or over the course of several days. When all of the necessary items are in place, Xerox personnel will complete the installation of the IPS components.

The steps in the installation process typically occur in the following order:

1. Xerox personnel install all IPS hardware and options at your site. This process takes approximately 24 hours if all of the necessary connectors are in place.
2. Xerox personnel place the system online.
3. Xerox personnel load the initial applications and run sample jobs.
4. Xerox personnel test the system and run sample jobs (30 minutes).
5. Xerox personnel conduct initial operations training (2 to 4 hours).
6. Xerox personnel review preventive maintenance schedules and service call procedures.

Your responsibilities

Xerox is responsible for the physical installation of the printer components and for loading the software and applications. You have the general site responsibility of ensuring that the right personnel and supplies are available.

At the time of installation, you should do the following:

- Make sure that your system administrator is available during the loading of software.
- If you plan to operate in Dual Mode, for software loading purposes, be prepared to provide Xerox personnel with any network information.
- Have test jobs ready to run.
- Have the necessary parameters defined to configure PSF for connectivity to your IPS printer.
- Have list of stocks you want used for your default input tray configuration.
- Have your operators available for training.
- Sysgen your host to print to an AFP1-type printer. Refer to the IBM ITSC *Distributing AFP Printing from a Host System* (#GG24-4493) documentation for further information.
- If your system will be channel-attached, make available a bus and tag connection from the host system as follows:
 - AS/400 requires a Barr/AFD or PS/2 with a channel card.
 - RS/6000 requires a channel card for IPS connectivity.
 - PS/2 requires a channel card for IPS connectivity.
- Make AFP application resources available at a resolution of 300 dpi to optimize output quality.
- Check the documentation and software kits against their packing lists for completeness.
- Remember you are responsible for supplying, installing, and maintaining your Token Ring or Ethernet Local Area network that connects your host with your printer controller.

Refer to the installation planning checklist in the “Preparing for installation” chapter of this guide for a complete list of responsibilities.

Defining the IPS printer to the host

Prior to installation of your IPS printer, your host system must be configured to communicate with and print on the IPS. This requires defining several printer parameters to your host. The required information and configuration procedures differ according to your connectivity type (channel or TCP/IP), and your host and PSF environment. You will need to provide these parameters to your Xerox representative on installation day.

There are two appendices in this guide which provide printer configuration procedures and the parameters you must define in order to configure PSF to make a connection with your IPS. Appendix A discusses channel-attached environments; appendix B provides information for environments in which the IPS uses TCP/IP to communicate via Ethernet or Token Ring. Parameters are given for MVS mainframes, AS/400, RS/6000 running AIX, and PS/2 or other personal computers running OS/2.

Software licensing

When an IPS is purchased, the owner needs to receive a license to use the operating system software. Once a user calls in with a host ID, (Sun SPARC/Ultra host ID), the user receives a license string. Refer to the "Setting up the printer controller" chapter in the *Guide to Configuring and Managing the System* (section titled "Loading the IPS software license text stream").

This license is enabled by entering a 20-character authorization text string at the printer controller keyboard. Your Xerox or Xerox Ltd. service representative obtains this license text string for you and enters it when your IPS is installed.

Until this license string is entered, your IPS cannot receive data from the host to print. You can power on and boot the system, and perform all offline tasks such as setting up input and output configurations, but the IPS remains in Disabled mode and cannot print.

Although your service representative usually does this for you, you also can enter your license string, by selecting IPS Authorization Enablement from the Administration pulldown menu on the IPS Main window. Refer to your IPS *Guide to Configuring and Managing the System*, "Setting up the printer controller" chapter, for the procedure.



Note: If your system will be operating in Dual Mode, it requires two license strings: one for IPS and one for NPS. □

Ongoing maintenance

After the installation of your Xerox DocuPrint IPS, there are a few ongoing tasks that must be performed. These tasks may include the following:

- Maintaining an adequate inventory of consumable supplies
- Overseeing routine maintenance and meter reporting
- Arranging for additional operator training
- Ordering additional fonts
- Ordering additional documentation
- Placing service calls for hardware problems
- Obtaining assistance in solving software-related problems.

As installation coordinator, it is your responsibility to designate the staff members responsible for these tasks.

Routine maintenance

A number of routine maintenance tasks must be performed to ensure maximum efficiency of your printer. These tasks include:

- Adding standard dry ink to your printer
- Adding fuser lubricant
- Replacing the dry ink and developer waste containers
- Cleaning the exterior surfaces of the system.

Step-by-step instructions on performing these routine maintenance tasks are contained in your *Guide to Performing Routine Maintenance*. You need to decide how many operators will be responsible for performing these maintenance tasks. Most maintenance procedures are covered in the initial operator training provided shortly after installation.



Note: Only operators who have completed the Xerox Advanced Customer Training (ACT) course, eXcellerate course, or equivalent advanced customer training can replace stitcher wire. Refer to the “Xerox support services” appendix in this guide for additional information on training.

Meter reading and reporting

As print jobs are processed, the printer controller accumulates, saves, and maintains usage data.

During the last five working days of each month, you need to review and transmit the data to Xerox for billing purposes. Refer to your *Guide to Performing Routine Maintenance* for complete instructions on how to report meter readings.

This appendix provides information and specifications for the media you use with your Xerox DocuPrint 4050 or 4090 printer. Instructions for ordering supplies are also provided.

Consumable supplies (those that are depleted during operation of the system), such as paper, dry ink, developer, fuser agent, etc., must be ordered for your printer. It is important that an adequate supply of these items be on hand for installation, and that your supply be maintained afterwards.

Paper and other throughput stocks

The success of any print run is greatly dependent on the proper selection, care, and handling of the stock used.

Selecting paper

You need to select your paper carefully. If you do not use the proper paper, you increase the probability of paper jams and misfeeds. The stocks you use must meet the specifications set forth by Xerox for operability in the printer. For additional information about paper specifications, refer to your *System Overview Guide* and to *Helpful Facts about Paper*, both delivered with your printer.

Acceptable paper stocks and sizes

Your 4050 or 4090 printer accepts the following standard size cut-sheet papers:

- US Letter: 8.5 by 11 inches / 216 by 279 mm
- US Legal: 8.5 by 14 inches / 216 by 356 mm
- A4: 8.27 by 11.69 inches / 210 by 297 mm

Recommended weight and grade:

Use a good quality, xerographic-grade paper. For best results, use paper that is 20-pound or 80 gsm (grams per square meter) bond, xerographic grade. Xerox 4024 Dual Purpose Paper provides optimal performance in the printer. Refer to the consumable supplies table in this appendix.

Use paper within these parameters:

- Lightest: 20-pound or 80 gsm bond
- Heaviest: 110-pound or 200-gsm index.

Characteristics

The paper stock should have the following characteristics:

- Low moisture content (a paper-to-moisture ratio below 5.7 percent). Paper with higher moisture content may curl and jam.
- Smooth surface
- Moisture-resistant wrapping
- No defects (bent edges, uneven surfaces)
- Grain long (parallel with the long side of paper).

Paper is usually fed into the printer with the long side as the leading edge. When you purchase paper, buy long-grain paper. Make sure the grain is parallel with the long side (long-grain) for the most reliable feeding and stacking.

Special stocks

Following are some guidelines for choosing and using special materials:

- **Labels** — Must be the type designed for high-speed printers and must meet the specifications described in the section above. Loading instructions are printed on all paper trays.

Load labels with the label side up. You can direct them to any output tray.

- **Transparencies** — Must be the type designed for high-speed printers and must meet the specifications described in the section above. Loading instructions are printed on all paper trays.

Load transparencies with the opaque strip to the right. All printed transparencies are delivered to the sample tray.

As long as they meet your printer's paper specifications, you can also use:

- **Tinted paper** — Available in a variety of colors, it has many uses, including calling attention to certain printed material, separating special sections, or dividing chapters of a report.
- **Preprinted paper** — May be letterhead, forms, or logos.
- **Predrilled paper** — Has a varying number of holes for use in binders or binder rings. Before loading predrilled paper, fan it to remove loose plugs that could cause paper jams. Load predrilled paper in the printer with holes to the right.
- **Perforated paper**

Paper care

Once you have purchased your paper, you must be sure it is stored and conditioned properly, so that it performs optimally in the printer with a minimum of jams.

Storing paper

Paper has a tendency to curl under the heat that is present inside xerographic equipment. To minimize the amount of curling, use paper with low moisture content. Paper with excessive moisture content has a tendency to jam because of the greater curl. The maximum recommended moisture content is 5.7 percent.

Keep these points in mind when preparing your paper storage area:

- Store paper in its own wrapper; do not leave it unwrapped or where it can be damaged by dampness or heat.
- Store paper on a flat surface and not on its side or edge.
- Store reams of paper in a closed cabinet.
- Always store paper in a cool, dry area. Store on pallets or shelves, not on the floor.
- Plan ahead and keep at least a day's supply of paper in the same area as the printer to allow environmental stabilization prior to printing.

For more detailed information on paper for Xerox printers, refer to *Helpful Facts about Paper*, provided with your printer.

Figure A-1. **Storing paper correctly**

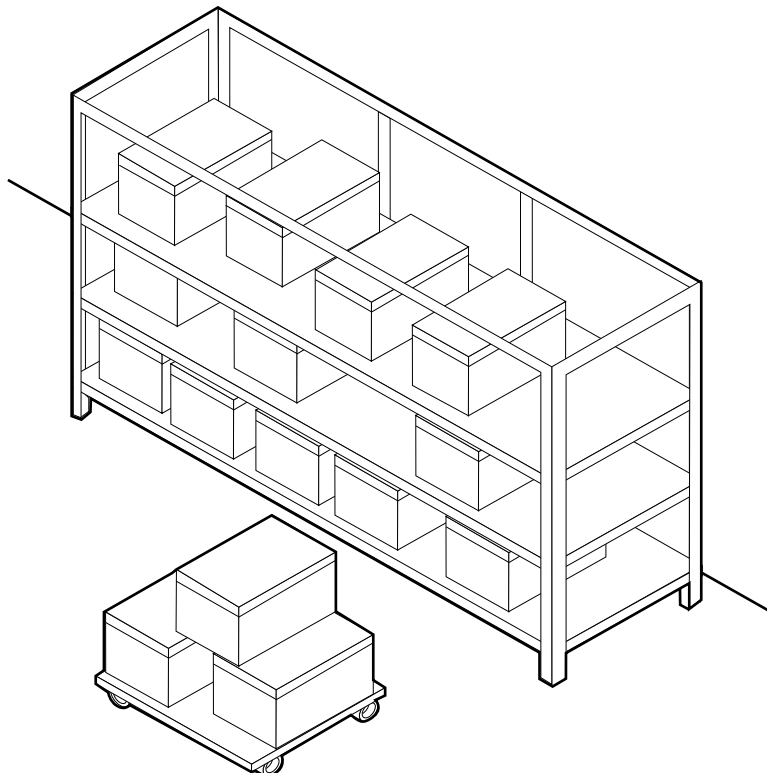
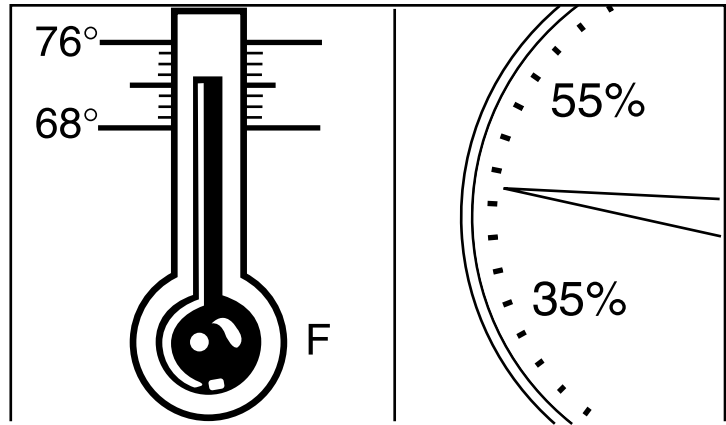

Figure A-2. **Recommended temperature and humidity for paper storage**



Conditioning paper

Because temperature and humidity affect paper performance in the printer, you need to condition paper before using it. To do this, store paper for a specified length of time in the same type of environment as your printer.

The length of time you should condition your paper depends on the amount of paper and the difference between the storage and operating temperatures.

Use the following chart to determine the length of time needed to condition stacked cartons of paper.



Note: The numbers in the top two rows indicate the temperature difference between the storage area and the operating environment, not actual room temperatures.

Table A-1. **Paper conditioning: Recommended temperature differences between storage and operating areas**

Temperature differences between storage and operating areas							
Fahrenheit							
10°	15°	20°	25°	30°	40°	50°	
Centigrade							
5.5°	8.5°	11°	13°	17°	22°	28°	
Cartons	Hours						
1	4	8	11	14	17	24	34
5	5	9	12	15	18	25	35
10	8	14	18	22	27	38	51
20	11	16	23	28	35	48	67
40	14	19	26	32	38	54	75

Example: (See the shaded rows in the table above.) If you want to move ten cartons of paper from a storage area with a temperature of 90 °F to an operating area with a temperature of 75 °F (a 15° difference), you should do so at least 14 hours before using the paper.

Other supplies

This section describes the supplies other than paper that are necessary for installation and afterward. Your sales representative will help you place your initial supply order.

Dry ink

Dry ink (also called toner) is the black powder which forms the image on the printed page. There are three cartridges of dry ink in each carton. You should keep at least one extra cartridge on hand at all times. The disposable cartridges are easily changed with no mess. The consumption rate of Xerox dry ink is approximately one cartridge per 45,000 pages. Use only dry ink that is specified for use in the 4050 or 4090 printer, as described in the consumable supplies table.

Fuser lubricant

Fuser lubricant is a consumable item required by the printer. You should keep at least two boxes (each box contains two tubes) on hand for installation by the service representative. The consumption rate of Xerox fuser lubricant is approximately one tube per 120,000 pages. For product information, refer to the consumable supplies table in this appendix.

Developer

Developer is not consumed by the printer but does have an effective life of approximately 300,000 pages per bottle, guaranteed by Xerox. Developer is a required item and must be kept on hand.

Use only the developer specified for use in your 4050 or 4090 printer.

The developer is changed by your service representative. For product information, refer to the consumable supplies table in this appendix.

Diskettes

Diskettes are optional items that provide loading and backup of fonts, forms, and user files to and from the printing system. The processor accepts 3.5-inch, 1.44 MB, double-sided, high density diskettes.

Cartridge tapes

The optional 4 mm cartridge tape drive uses 5 GB or 8 GB tapes.

Fonts

Data can be printed on DocuPrint printers in many sizes and type styles called fonts. A font is a character set which has unique characteristics, such as type style, size, weight, orientation (portrait, landscape, inverse portrait, and inverse landscape), character spacing (fixed and proportional), line spacing, and postures (Roman, italic, and so forth).

There are three classifications of fonts:

- Standard fonts
- Licensed fonts
- Custom fonts.

Standard fonts	A library of 51 fonts is provided with your printer's operating system software.
Licensed fonts	Additional fonts may be ordered from your local Xerox Font Center.
Custom fonts	Custom fonts and graphic images such as company logos and signatures can be digitized by the Xerox Font Center for use on your printer.
Receiving fonts	Fonts are received on a diskette from your local Xerox Font Center.

Consumable supplies tables

A number of supplies are available from Xerox for your DocuPrint printer. Use the following tables to help determine your supply needs.



Note: Customers in the U. S. may use the part numbers in these tables to order supplies. Customers outside the U. S. should contact their local service organization for part numbers.

Paper and special stocks tables

The following tables list all throughput stocks available for the 4050/4090 printers, with size, order number, and a brief description for each.

Table A-2. **Stocks list for 4050/4090 printers**

Item	Description	Part number
Paper	Xerox paper quantities are 10 reams (5,000 sheets) to a carton unless otherwise noted below.	
8.5 x 11 inch	4024 Dual Purpose Paper	3R721
A4	4024 Dual Purpose Paper	3R2594
8.5 x 14 inch	4024 Dual Purpose Paper	3R727
8.5 x 11 inch	4024 Dual Purpose Paper, 3-hole	3R723
8.5 x 11 inch	4024 Dual Purpose Paper, 3-hole*	3R2193
8.5 x 11 inch	4024 Dual Purpose Paper, 4-hole	3R1983
8.5 x 11 inch	4024 Dual Purpose Paper, 4-hole*	3R3008
8.5 x 11 inch	4024 Dual Purpose Paper, 7-hole	3R1984
8.5 x 11 inch	4024 Dual Purpose Paper, 7-hole*	3R3010
8.5 x 11 inch	4024 Smooth	3R2675
8.5 x 14 inch	4024 Smooth	3R2677
8.5 x 11 inch	Dual Purpose Colors—Blue	3R3052
8.5 x 11 inch	Dual Purpose Colors—Blue, 3-hole	3R3068
8.5 x 14 inch	Dual Purpose Colors—Blue, 3-hole	3R3084
8.5 x 11 inch	Dual Purpose Colors—Green	3R3056
8.5 x 11 inch	Dual Purpose Colors—Green, 3-hole	3R3072
8.5 x 14 inch	Dual Purpose Colors—Green	3R3088
8.5 x 11 inch	Dual Purpose Colors—Pink	3R3058
8.5 x 11 inch	Dual Purpose Colors—Pink, 3-hole	3R3074
*5/16-inch drilled holes		
** Rainbow pack contains 750 sheets each of blue and yellow, 500 sheets each of green and pink, and 250 sheets each of buff, gray, goldenrod, and ivory.		

Table A-2. **Stocks list for 4050/4090 printers** (continued)

Item	Description	Part number
8.5 x 14 inch	Dual Purpose Colors—Pink	3R3090
8.5 x 11 inch	Dual Purpose Colors—Yellow	3R3054
8.5 x 11 inch	Dual Purpose Colors—Yellow, 3-hole	3R3070
8.5 x 14 inch	Dual Purpose Colors—Yellow	3R3086
8.5 x 11 inch	Dual Purpose Colors—Buff	3R3060
8.5 x 11 inch	Dual Purpose Colors—Buff, 3-hole	3R3076
8.5 x 14 inch	Dual Purpose Colors—Buff	3R3092
8.5 x 11 inch	Dual Purpose Colors—Goldenrod	3R3062
8.5 x 11 inch	Dual Purpose Colors—Goldenrod, 3-hole	3R3078
8.5 x 14 inch	Dual Purpose Colors—Goldenrod	3R3094
8.5 x 11 inch	Dual Purpose Colors—Ivory	3R3064
8.5 x 11 inch	Dual Purpose Colors—Ivory, 3-hole	3R3080
8.5 x 14 inch	Dual Purpose Colors—Ivory	3R3096
8.5 x 11 inch	Dual Purpose Colors—Gray	3R3066
8.5 x 11 inch	Dual Purpose Colors—Gray, 3-hole	3R3802
8.5 x 14 inch	Dual Purpose Colors—Gray	3R3098
8.5 x 11 inch**	Dual Purpose Colors, Rainbow Pack—35,000 sheets per carton**	3R3107
8.5 x 11 inches	4200 Primary Image	3R5802
8.5 x 14 inches	4200 Primary Image	3R5804
8.5 x 11 inches	4200 Primary Image, 3-hole	3R5803
8.5 x 11 inch	10 Series Dual Purpose Paper	3R2950
8.5 x 11 inch	10 Series Dual Purpose Paper, 3-hole	3R2952
8.5 x 11 inch	10 Series Dual Purpose Paper, 3-hole*	3R3016
8.5 x 14 inch	10 Series Dual Purpose Paper	3R2954
8.5 x 11 inch	10 Series Smooth	3R54
8.5 x 14 inch	10 Series Smooth	3R83
8.5 x 11 inch	4024 Dual Purpose, reinforced 3-hole*	3R2057
*5/16-inch drilled holes		
** Rainbow pack contains 750 sheets each of blue and yellow, 500 sheets each of green and pink, and 250 sheets each of buff, gray, goldenrod, and ivory.		

Table A-2. **Stocks list for 4050/4090 printers** (continued)

Item	Description	Part number
Transparencies	Xerox transparencies are packaged 100 sheets to a box.	
8.5 x 11 inch	Clear, with a white strip on the edge	3R2780
8.5 x 11 inch	Clear, high speed, with paper backing	3R3028
Labels (Gummed)	Xerox labels are packaged 100 sheets to a box.	
8.5 x 11 inch	33 labels per sheet	3R3139
8.5 x 11 inch	6 labels per sheet	3R3146
8.5 x 11 inch	Custom form (uncut)	Contact Xerox Supplies Order Service
8.5 x 11 inch	1-up label	3R4476
8.5 x 11 inch	1-up label	3R4475
8.5 x 11 inch	1-up label	3R4474
Cover stock	Xerox cover stock is packaged 2,500 sheets per carton.	
8.5" x 11"	65-pound, blue	3R3044
8.5" x 11"	65-pound, white	3R3041
*5/16-inch drilled holes ** Rainbow pack contains 750 sheets each of blue and yellow, 500 sheets each of green and pink, and 250 sheets each of buff, gray, goldenrod, and ivory.		

Complete supplies list—4050/4090 printers

The following table lists the supplies in addition to paper that are available for your printer. Use this table to help you determine your supplies needs.

Table A-3. **Complete supplies list for 4050/4090**

Item	Description	Part number	Items/ carton	Expected yield
Developer material	Packaged one container per carton. (Needs replacement only if current supply becomes contaminated.)	5R302	1/carton	
Diskettes	3.5-inch, 1.44 MB, double-sided, high density diskettes. Packaged 10 diskettes per box.	8R7683	10/box	
Dry ink	Dry ink is packaged six bottles per carton. (Consumption rate is approximately 45,000 pages per bottle.)	6R301	6/carton	270,000 prints/carton
Fuser lubricant	Packaged two tubes per carton.	8R983	2/carton	240,000 prints/carton
Cartridge tape	4mm blank cartridge tape, 5GB	9R01190		
	4mm blank cartridge tape, 8GB	109R00314		
Cleaning supplies	4mm cartridge head cleaning kit	9R01189		
	Foam-tipped swabs	99P87256		
	Lint-free towels	35P2163		
Stitcher wire	Packaged one reel per box.	8R1174	One reel	32,000 staples

Ordering supplies

To avoid unnecessary downtime, always have an adequate amount of the necessary supplies. To do this, you need to establish a procedure for checking and ordering supplies. A supplies checklist is provided at the end of this appendix to help you with this task. It lists the supplies needed for the printer and contains a column for you to enter the date when you want to place the order and a column to record the date of the actual order. The consumable supplies table, above, contains a list of Xerox supplies available for the printer.

It is important that you check your supplies regularly and order before you run out. Plan on approximately five working days for delivery after placing the order. You can make arrangements to receive them sooner in emergency situations.

Your Xerox sales representative can help you submit the initial order of supplies needed for installation. These items include paper, dry ink, fuser lubricant, and developer.

Once your printer volume is established, planning ahead and buying Xerox supplies in quantity can save you money. Your Xerox supply specialists can help you. There are two centers available to assist you:

- To order Xerox paper, transparencies, labels, dry ink, developer, fuser lubricant, stitcher wire, cartridge tapes, and diskettes, call the Xerox Supply Center at 1-800-822-2200, weekdays between 7:30 a.m. and 6:00 p.m., Pacific time.

If you prefer, you may mail orders to the following address:

Xerox Corporation
P. O. Box 25075
Santa Ana, CA 92799-5075

- To order cleaning supplies, call the Xerox Customer Parts and Product Support Center at 1-800-828-5881, weekdays between 5:30 a.m. and 5:00 p.m., Pacific time, (U.S. only).

You may also mail cleaning supply orders to the following address:

Xerox Corporation
Parts Marketing Center
Building 214-07S
P. O. Box 1020
Webster, NY 14580

Please provide the following information when placing orders:

- Your customer number (provided by your Xerox sales representative)
- Your printer model: Xerox DocuPrint 4050 or Xerox DocuPrint 4090
- Your supply order, including the following information:
 - Item name
 - Part number
 - Quantity desired

- If your company requires a purchase order for payment of an invoice, you need to provide the purchase order number to Xerox at the time you place the order.

The following table is a checklist you can use to keep track of the supplies you order.

Table A-4. Supplies checklist for 4050/4090 printer

Supplies checklist Use this checklist to help record the supplies and accessories you need, the date you plan to place the order, and the actual date of the order.				
Item	Description and part number	Quantity	Date to order	Date ordered
Paper				
Transparencies, labels, and special stocks				
Dry ink				
Fuser lubricant				
Diskettes				
Stitcher wire				
Cartridge tapes				
Cleaning supplies				

B. Xerox support services

Xerox provides many services in support of your laser printing system. This appendix contains information on the following services:

- Xerox Customer Service Support Center
- Xerox Printing Systems Customer Support Center
- *Xerox Customer Documentation Catalog*
- Xerox Documentation and Software Services (XDSS)
- Operator training
- Xerox Customer Education
- Xerox Font Center.

Prior to installation, your sales representative is available to answer your questions about products, services, or billing. In the U. S., however, if you need assistance in resolving application-related problems or questions, call the Xerox Printing Systems Customer Support Center (refer to the following section of this chapter). Your systems analyst is also available to assist you with applications development.



Note: For customers outside the United States, contact your local Xerox representative or operating company for information on available support services.

Xerox Customer Service Support Center

The Xerox Customer Service Support Center provides regular maintenance care for your printer as well as any necessary repairs. Call the Service Support Center if your printer has a hardware-related problem such as poor print quality, repeated paper jams, or connectivity problems.

Before calling your Customer Service Support Center, make sure you have tried the corrective actions described in your *Troubleshooting Guide*. If a problem persists, gather the necessary information and call your customer service support center.

In the United States, call the following number to report DocuPrint hardware or software problems:

1-800-821-2797



Note: This phone number is attached to your printer at installation time. □

Before contacting service, make note of the following:

- Status code numbers and messages which appear on the keyboard/display
- Status messages which appear on the printer control console
- Indicator lights that are lit.

Your call is answered by a representative, who asks you for the model number and the serial number for your printing system, and for the following:

- Serial number for your printing system
- Your name
- Company name
- System condition or status

Give this information to a customer service representative, who will call you back to help you resolve the problem over the phone, or to give you an estimated time of arrival.

Xerox support personnel may use the Sixth Sense Remote Service feature to access IPS/NPS controller information via modem from a remote location. More information about Remote Service can be found in the *Xerox DocuPrint 96/4635/180 IPS Troubleshooting Guide*.

Xerox Printing Systems Customer Support Center

The Xerox Printing Systems Customer Support Center is available to address your application problems or to direct you to the appropriate documentation.

The key to effective use of the Xerox Printing Systems Customer Support Center is correct identification of the problem. Before calling the center, it is helpful to have the following information available:

- The correct name of your system, such as the Xerox DocuPrint 4050 IPS or the Xerox DocuPrint 4090 IPS.
- A list of any error messages
- An explanation of how output is different from what was expected.
- An assessment of whether the symptoms follow a pattern or occur randomly.
- A list of special conditions that may have caused the problem:
 - New applications
 - Changes made to the software
 - Recent service performed
 - Previous conditions under which the application has printed properly.

To contact the Xerox Printing Systems Customer Support Center, call: **1-310-333-0501** (U. S. only), between the hours of 5:00 a.m. and 5:00 p.m., Pacific time.

Xerox Customer Documentation Catalog

Detailed information on documentation for DocuPrint printers and other Xerox products is contained in the *Xerox Customer Documentation Catalog*. The catalog includes a brief description of each item and its cost.

Once you are on the mailing list, updated catalogs are sent to you automatically. You may call Xerox Documentation and Software Services (XDSS) to request a catalog. Refer to the following section for further information.

Xerox Documentation and Software Services (XDSS)

XDSS offers a variety of services that can be customized to meet your documentation needs.

XDSS distributes the documents you need to facilitate the installation and use of the DocuPrint printer, other Xerox printers, and associated software.

XDSS will also send you a *Xerox Customer Documentation Catalog* free of charge upon request. To order documents or request a *Xerox Customer Documentation Catalog*, call XDSS at **1-800-327-9753**, between the hours of 6:00 a.m. and 5:00 p.m., Pacific time (U. S. only).

XDSS representatives will explain the services available, answer your questions, and take orders for documentation.

XDSS also has a web page from which you can order customer documentation and/or obtain a catalog. Its address is:

<http://www.XDSS.com>

Operator training

Operator training is conducted at your location by your Xerox system analyst or other identified representative, shortly after the printer is installed. Training takes two to four hours, depending on the system configuration. It includes hands-on practice running basic jobs, performing routine maintenance, and solving problems. Determine the number of operators you want to attend the initial training and schedule training dates and times through your Xerox sales representative.

Additional training classes, such as Advanced Customer Training (ACT) for operators, teach advanced service and maintenance skills. Your sales representative can give you information on availability of ACT training.

A variety of classes and workshops are available through Xerox Customer Education (refer to the following section).

Xerox Customer Education

Xerox offers classes and tutorial documents on various topics relating to printing systems and document production. For information about Xerox training courses, or to receive a catalog, call Xerox Customer Education at **1-800-445-5554** (U. S. only). Customer Education has a web page where you can obtain additional information. Its address is:

<http://xwww.dsss.world.xerox.com/CustomerEd>

Xerox Font Center

The Xerox Font Center can send you samples and catalogs of the fonts available for your printer.

To receive font samples, obtain price information, obtain technical support, or order licensed or custom fonts, call **1-800-445-FONT (-3668)** between 6:00 a.m and 5:00 p.m. Pacific time (U. S. only).

For technical support regarding fonts (such as installing fonts or solving font usage problems), call **1-800-521-8324**.

C. Related publications

The *Xerox DocuPrint 4050/4090 IPS Installation Planning Guide* is part of the *Xerox DocuPrint IPS Series* publication set.

Xerox documents

Following are related Xerox documents. For a complete list and description of available Xerox documentation, refer to the *Xerox Customer Documentation Catalog* (publication number 610P17517), or call your service representative.

Title

Xerox DocuPrint IPS/NPS Operator Training Instructor Guide

Xerox DocuPrint IPS Operator Training Participant Guide

Xerox DocuPrint IPS Messages Guide

Xerox DocuPrint 4050/4090 IPS Guide to Performing Routine Maintenance

Xerox DocuPrint 4050/4090 IPS Guide to Configuring and Managing the System

Xerox DocuPrint 4050/4090 IPS System Overview Guide

Xerox DocuPrint 4050/4090 IPS Troubleshooting Guide

Xerox Standard Font Library Font User Guide

Helpful Facts About Paper

Xerox DocuPrint IPS Solutions Guide

IBM documents Following are related IBM documents. Contact your local IBM representative for ordering instructions for IBM AFP/PSF manuals that might be useful for your specific installation.

Title

IBM 3825 Page Printer Product Description

IBM Intelligent Printer Data Stream Reference

IBM Advanced Function Presentation Printer Summary

IBM ITSC Distributing AFP Printing from a Host System

IBM Advanced Function Printing Data Stream Reference

IBM Data Stream and Object Architectures: Mixed Object Document Content Architecture Reference

Guide to Advanced Function Presentation

Attachment Configuration Handbook

AFP IBM Print Services Facility for OS/2

*ES 3090/9000 Input/Output
Program User's Guide*

MVS/ESA Hardware Configuration Definition

IBM AIX Print Services Facility/6000: Print Administration

VM/ESA Planning and Administration

D. Defining the channel-attached printer to the host

This appendix contains some explanations and sample printer parameters for defining a channel-attached IPS printer to your host, in each PSF environment.

MVS parameters

This section gives examples of printer device parameters and definitions in the MVS mainframe environment using PSF/MVS.

Printer definitions for MVS versions earlier than 4.1.0

The following shows sample parameters for a channel-attached printer such as the IPS, in an MVS environment using versions earlier than 4.1.0.

- JES2 definitions

- Functional Subsystem (PSF) Definition

```
FSSDEF(FSS1) PROC=APSWPROC,AUTOSTOP=0,  
HASPFSSM=HASPFSSM
```

- PSF Printer Definition

```
PRT (6) FSS=FSS1,MODE=FSS,PRMODE=(LINE,  
PAGE,SOSI1),CLASS=F,UCS=0,SEP=YES,SEPDS,CKP  
TPAGE=100,START=NO,MARK=YES,UNIT=1E9
```

- Channel address (2-bytes)
- Channel mode (high-speed data transfer)
- Superuser password
- Printer name and boot name
- Having proper resources (such as 300 dpi fonts).

- PSF definitions

```
//PRT6 CNTL  
//PRT6 PRINTDEV FONTDD=*.FONT01,  
//          FDEFDD=*.FDEF,  
//          PDEFDD=*.PDEF,  
//          OVLYDD=*.OLAY,  
//          PSEGDD=*.PSEG,  
//          JOBHDR=*.JOBHDR,  
//          JOBTRLR=*.JOBTLR,  
//          DSHDR=*.DSHDR,  
//          MESSAGE=*.MSGDS,  
//          PAGEDEF=  
//          FORMDEF=  
//          CHARS=
```

```
//          PIMSG=
//          DATAK=
//          BUFNO=
//          TRACE=
//          DUMP=
//PRT6  ENDCNTL
```

- AFP1 definition
 - CTL37E8 CNTLUNIT
 - CNUMBER= E8 , PATH=(37) , PROTOCOL=D , SHARED=N , UNIT=AFP1 , UNITADD=((E8 , 2) 22)
 - PRT37E8 IODEVICE CUNUMER=1E8 ,
 - UNIT=AFP1 , ADDRESS=(IE8 , 2)
 - 3825 or AFP1 device definition
 - VTAM definition
 - NCP definition
 - 3174 definition (7-ring)

Printer definitions for MVS versions 4.1 and higher

The following are examples of MVS hardware configuration definition (HCD) printer definition panels. This is the information you use when printing in the PSF/MVS environment for MVS versions 4.1.0 and higher.

Figure D-1. MVS hardware configuration definition panels

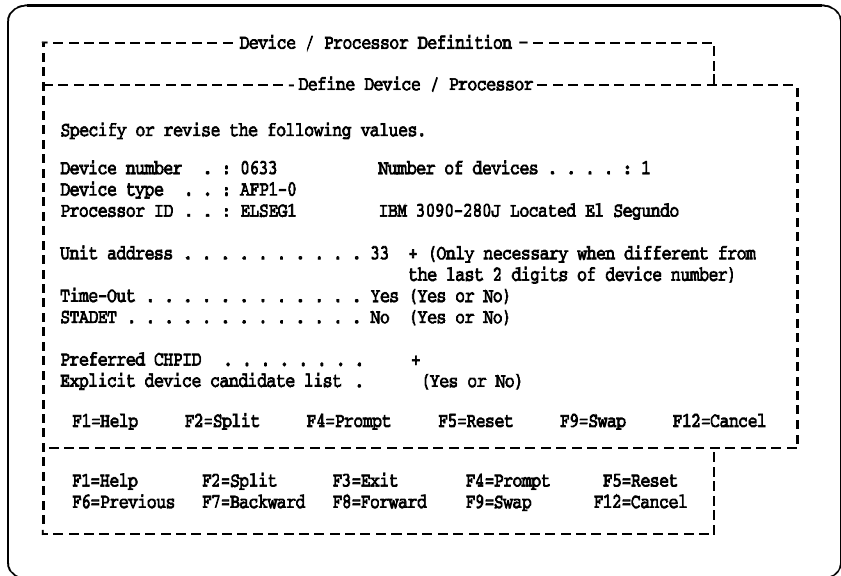

Goto Filter Backup Query Help

----- Change Device Definition -----

Specify or revise the following values.

Device number : 0633 (0000-FFFF)
Device type : AFP1-0

Serial number
Description : Art Ford

Connected to CUs . 0633

ENTER to continue

F1=Help F2=Split F3=Exit F4=Prompt F5=Reset F9=Swap
F12=Cancel

F1=Help F2=Split F3=Exit F4=Prompt F5=Reset F7=Backward
F8=Forward F9=Swap F10=Actions F11=Add F12=Cancel

----- Define Device Parameters / Features -----

Row 1 of 3

Command ==>

Scroll ==> PAGE

Specify or revise the values below.

Configuration ID . : ELSEG1 MVS/ESA Hardware Definitions
Device number . . : 0633 Number of devices : 1
Device type . . . : AFP1-0

Parameter/ Feature	Value	P Req.	Description
OFFLINE	Yes		Device considered online or offline at IPL
DYNAMIC			Device supports dynamic configuration
BURSTER	No		Burster-Trimmer-Stacker

*****Bottom of data*****

F1=Help F2=Split F4=Prompt F5=Reset F7=Backward
F8=Forward F9=Swap F12=Cancel

For further information on defining your printer, refer to the following IBM documentation.

- *ES3090/9000 Input/Output Program User's Guide (#GC38-0095)*
- Chapter 5, "How to define, modify, or view a configuration" in the *MVS/ESA Hardware Configuration Definition (#SC33-6468)*

OS/2 procedures

This section gives examples of printer device parameters and definitions for a channel-attached in the OS/2 environment using PSF/2.

To print using PSF/2, you must identify the IPS to the PSF/2 print server by setting up a device for the IPS.

1. From the Profile pulldown menu, select New. The New Device window displays.

Figure D-2. OS/2 New Device window

New device

Enter the following information to create a new device:

Device name: 4635 IPS

Path: C:\PSF2SYSTEM

Description:

Attachment Type

- Channel
- Communication
- Parallel
- TCP/IP

Settings...

Device Resolution: 300 PEL

Create Cancel Help

2. In the New Device window, enter the name of the new device (for example, 4890 IPS) in the "Device name" field.
3. In the "Path" field on the New Device window, use the default path or enter a path to indicate where the device settings and other associated files are located.
4. In the "Description" field on the New Device window, enter a description of the new device, as necessary.
5. From the Attachment Type list box on the New Device window, select Channel.
6. Click [Settings] on the New Device window. The Channel Attachment Settings window displays.
7. From the Channel Slot pulldown menu on the Channel Attachment Settings window, select or enter the channel address.
8. In the "Control Unit Address" field on the Channel Attachment Settings window, enter the two-digit address for the control unit.

9. In the “Form Definition” field on the Channel Attachment Settings window, use the default form destination, unless one is defined by the application.
10. On the Channel Attachment Settings window, make sure that the 3829 Printer checkbox is not checked. When this checkbox is checked, uncheck it to disable this option.
11. Click [OK] on the Channel Attachment Settings window. The New Device window displays.
12. From the Device Resolution pulldown menu on the New Device window, select 300 PEL.
13. Click [Create] on the New Device window to create the device for your IPS.

For further information, refer to the “Defining a printer” chapter in the IBM document, *AFP IBM Print Services Facility for OS/2 - a Guide to Using PSF/2* (#G5440-5225)

AIX procedures

This section provides references to detailed information on channel-attaching an IPS printer to an RS/6000 in an AIX environment using PSF/6000 or InfoPrint Manager.

PSF/6000 For details on configuring PSF/6000 so it recognizes your channel-attached printer, refer to the “Adding a Channel-Attached Printer to PSF/6000” chapter in the *IBM Print Services Facility for AIX: Print Administration* manual (#S544-3817). This manual is available in PDF format at the following IBM website:

<http://www.printers.ibm.com/R5PSC.NSF/Web/manuals/opsevm>

InfoPrint Manager For details on configuring InfoPrint Manager so it recognizes your channel-attached printer, refer to Part 2, “Expanding Your InfoPrint System” in the *IBM InfoPrint Manager for AIX: Administrator's Guide* (#S544-5595). This manual is available in PDF format at the following IBM website:

<http://www.printers.ibm.com/R5PSC.NSF/Web/manuals/infprtm>

VM sample definitions

This section gives an example of printer device parameters and definitions for a channel-attached IPS in a mainframe VM environment using PSF/VM.

```
CNTLUNIT CUNMBR=632,
PATH=16,
PRTOCL=S,
SHARED=N,
UNIT=AFP1,
UNITADD=(32,02)
```

```
IODEVICE CUNMBR=632,
UNIT=AFP1,
ADDRESS=(632,02)
```

```
Rdevice 0630-0637 Type AFP
```

For further information, refer to Chapter 7, "System Configuration File" in the IBM document, *VM/ESA Planning and Administration* (#SC24-5750).

VSE sample definitions

This section shows sample parameters for a channel-attached printer such as the IPS in a mainframe VSE environment, using PSF/VSE.

```
* $$ JOB JNH=APSTANO,DISP=L,PRI=3,CLASS=B
* $$ LST CLASS=A,DISP=0,PRI=9
// JOB APSTANO
// OPTION NODUMP
// DLBL IMSYS `IMSYS`
// EXTENT ,SYSWK6
// DLBL IMSYS `IMSYS`
// EXTENT ,SYSWK6
LIBDEF *,SEARCH=(IMSYS.AFP300,
IMSYS2.PAGELIB,IMSYS2.PARMLIB,IMSYS.PRSABC,
IMSYS.PR$ADA,IMSYS.PR$ADB,IMSYS.PR$DY8,
IMSYS2.COMPAREX,IMSYS2.FONT,IMSYS2.FORMLIB,
PRD2.AFP,IMSYS.PROD,PRD2.AFP240,PRD2.AFP300
// EXEC APTBMIEP,SIZE=APTBMIEP
X3820 PRINTDEV BUFNO=10
CHARS=GT12
CKPTPAGE=100
DATAACK=BLKCHAR,
FONTPR=NO,
LOGDEST=LOCAL,
MRKFRM=NO,
NOTIFY=YES,
PIMSG=(YES,0),
SETUP=FORMS,
SPBUFFER=8
PAGEDEF=VO6683,
FORMDEF=AUTO,
UNIT=630
```

E. Defining the printer to the host: TCP/IP attachment

This appendix contains instructions, prerequisites, and some sample printer parameters for defining your TCP/IP-attached IPS printer to your host, in each PSF environment.

MVS or OS/390 parameters

This section discusses the parameters and procedures required to define an IPS printer to your host, followed by examples of the parameters required for a Token Ring connection using TCP/IP in a MVS environment.



Note: The MVS examples shown are for a Token Ring connection. However, the same parameters will be required for an Ethernet connection using TCP/IP.

Software prerequisites – MVS

On an MVS/ESA or OS/390 host system, you must have the following software to print through PSF on a TCP/IP-attached IPS:

- PSF/MVS Version 2, release 2.0, with APAR OW 15599
- MVS Scheduler APAR OW 12236 to support two new PRINTDEV keywords: IPADDR and PORTNO
- TCP/IP Version 3, release 1 or higher, installed and configured on MVS.

You must have these prerequisites installed on your host before you begin the configuration process described in this chapter. Ensure that the manuals for the proper software releases are used.

Network configurations – MVS

The IPS printer is supported in all the following configurations, provided that the software prerequisites are installed.

- Basic configuration in which the MVS host is attached to a LAN using a Token Ring or Ethernet network adapter card
- Remote LAN environment in which there are data communication links between the host and the LAN-attached controller

- Configurations in which the LAN with the printer attached is connected to the host-attached controller using LAN devices such as routers
- Environments with intermediate host systems between the MVS host running PSF and the LAN-attached controller.



Note: There may be printer performance and throughput implications with some of these configurations. It is recommended that your network management group be involved with planning this installation. □

Configuration steps – MVS

The software configuration process for IPS in an MVS or OS/390 environment with TCP/IP consists of five major steps:

1. Configure the IPS printer for TCP/IP at the GUI

Refer to your *IPS Guide to Configuring and Managing the System*, chapter 4, “Setting the system configuration,” for this graphical user interface (GUI) procedure.

2. Configure the MVS CCU for the MVS host to MVS

The MVS communications control unit (CCU) could be the 3172, 3174, or 3745 control unit. To configure it to MVS, you can use either a hardware configuration definition (HCD) or an MVS configuration program (MVSCP). If your control unit and LAN are already installed and operational, skip this step.



Note: The AFP1 parameter used when channel0attached IPDS printers are defined is not applicable in this configuration. It is the communications control unit (3172, 3174, or 3745) that is being defined to MVS, not the printer’s control unit. □

3. Configure the PSF printer in JES2 or JES3

This section discusses the procedures for configuring the IPS in JES2 or JES3 environments.

Configuring in JES2

To configure the PSF printer in JES2, follow these steps:

1. Locate the JES2 initialization dataset in the JES2 Startup JCL Procedure (JES2 PROC). (This is normally kept in SYS1.PROCLIB, although your system may use a different library.)

The JES2 PROC has a DD statement (normally HASPPARM), which points to the initialization dataset. (The location of this statement is ‘SYS1.PARMLIB(JES2PARM);’ however, you should always verify the location on your own system.)

2. Enter the following required commands in the JES2 initialization dataset to define the PSF functional subsystem (FSS):

- One FSS statement for each PSF functional subsystem
- One PRT $nnnn$ statement for each functional subsystem application (FSA) under control of the FSS. (This can also be specified as PRINT nn or PRINTER n .)

The following table lists the JES2 FSS statement parameters to be defined.

Table E-1. **JES2 FSS statement parameters**

Item description	Default	Source of value	Range of acceptable values	Comments	Your value
PROC	None	PSF Startup procedure name/	1 to 8-character alphanumeric string	Specifies name of procedure for starting this FSS. Different FSS statements can refer to the same startup procedure	
AUTOSTOP	NO	Installation preferences	YES or NO	Specifies whether FSS address space is stopped automatically if all FSAs under control of the FSS are stopped.	
HASPFSSM	HASPFSSM	JES2 Load module to be loaded into FSS address space	HASPFSSM	Either omit parameter or specify default value of HASPFSSM.	
CLASS	None	Installation output class standards	List of alphanumeric output classes	Can also be specified as QUEUE=	
COPYMARK	DATASET	Installation preferences	DATASET or JOB or CONSTANT	DATASET: IPS printer will offset-stack or stitch on a dataset boundary. JOB: IPS printer will offset-stack or stitch on a job boundary. CONSTANT: Copymarks are constant; no offset stacking or stitching is done.	
FORMS	None	Forms that will be printed on this printer	1 to 8 form names (each 1 to 8 alphanumeric characters in length)	If WS is F, only output with these form names will be selected for printing on this printer.	
FSS	None	Name of FSS	1 to 8-character alphanumeric string	Required	
MARK	NO	Installation preferences	YES or NO	YES specifies for IPS that there is either offsetting or stitching of jobs, subject to value of COPYMARK parameter and setting on IPS.	

Table E-1. JES2 FSS statement parameters (continued)

Item description	Default	Source of value	Range of acceptable values	Comments	Your value
MODE	FSS (if FSS= is coded)	Must be FSS	FSS	MODE=FSS should be specified.	
PRESELECT	YES	Installation preferences	YES or NO	Specifies whether output datasets are preselected for this FSA.	
ROUTECD	None	Installation printer name standards	1 to 4 destination names	If WS if F, only output with these destinations is selected for this printer.	
START	YES	Should be NO for TCP/IP printers.	YES or NO	START=NO should be specified so TCP/IP can be started before the FSS.	
TRKCELL	no	See JES2 SPOOLDEF statement	YES or NO	IBM recommends YES.	
WS	None	Installation preferences	See JES2 Initialization and Tuning Manual.	Consider CL, R, and F. See JES2 Initialization and Tuning Manual for more information.	

Following is an example of the JES2 Initialization Dataset required commands:

Table E-2. JES2 Initialization Dataset commands example

FSS (FSS1)	PROC=FSSPROC1 , HASPFSSM=HASPFSM , AUTOSTOP=YES
PRT0001	CLASS=E , FSS=FSS1 , MODE=FSS , PRESELCT=YES , START-NO , TRKCELL=YES , WS= (Q)

Configuring in JES3

Follow these steps to configure the PSF printer in JES3:

1. Locate the JES3 initialization dataset (commonly known as Initialization Deck) in the JES3 catalogued JCL Procedure. (This is normally kept in SYS1.PROCLIB, although your system may use a different library.)

The JES3 PROC has a JES3IN DD statement, which points to the initialization dataset. The default initialization deck is in SYS1.SAMPLIB (member JES3IN00); however, you should verify your location by looking at the JES3 procedure.

2. Enter the following required commands in the JES3 initialization deck to define the PSF functional subsystem (FSS):
 - One FSSDEF statement for each PSF functional subsystem
 - One DEVICE statement for each functional subsystem application (FSA) under control of the FSS.

The following table lists the JES3 FSS statement parameters to be defined.

Table E-3. JES3 FSS statement parameters

Item description	Default	Source of value	Range of acceptable values	Comments	Your value
FSSNAME	None	Installation preferences	1 to 8-character alphanumeric string	Specifies name of the FSS. (Required parameter)	
MSGDEST	JES	Installation preferences	JES or a destination class name	Specifies the console destination class for FSS messages.	
PNAME	None	Name of the FSS procedure	1 to 8-character alphanumeric string	Specifies the procedure for starting this FSS. (Different FSSDEF statements may refer to same procedure.)	
SYSTEM	Same as specified in JUNIT parameter of DEVICE statement	System ID of system the FSS is to run on.	Valid system ID name	Can also be specified as QUEUE=	
TERM	NO	Installation preferences	YES or NO	YES specifies FSS terminates if JES3 global address space is terminated.	
TYPE		TYPE=WTR must be specified	WTR	Specifies FSS is an output writer. TYPE=WTR must be specified.	
BURST	YES	Installation preferences	YES or NO ,M	,M specifies MARKFORM, which causes IPS printer to offset-stack or stitch jobs, subject to printer's setting and the COPYMARK parameter.	
COPYMARK	J	Installation preferences	N or J or C	C: IPS will offset-stack or stitch on a dataset copy basis. J: Printer is to increment offset stacking or stitching on a job boundary. N: Copymarks are constant, and no offset stacking or stitching is done.	
DGROUP	None	Installation printer destination naming conventions	1 to 8-character alphanumeric string	Specifies destination processed by this FSA (applicable only if D is specified in the WS parameter).	
DTYPE	None	PRTAFP1	PRTAFP1	Required parameter	
DYNAMIC	NO	Installation printer name standards	YES or NO	DYNAMIC=NO should be specified so JES3 will keep FSA active between transmission of datasets.	

Table E-3. JES3 FSS statement parameters (continued)

Item description	Default	Source of value	Range of acceptable values	Comments	Your value
FSSNAME	None	Name of FSA in JNAME parameter	1 to 8-character alphanumeric string	Must match value in FSSNAME parameter of FSSDEF statement.	
JNAME	None	FSSNAME parameter of FSSDEF statement	1 to 8-character alphanumeric string	Must match value in FSSNAME parameter of FSSDEF statement.	
JUNIT	ON	See comments.	(Device address, Main, dest class, ON/OFF)	Device address should not be specified for TCP/IP printers. Main is name of processor the FSS is to run on. Dest class is destination class for FSA messages. ON or OFF specifies whether FSA is initially online or offline.	
MODE	None	Must be FSS.	FSS	MODE=FSS must be specified.	
WC	Any class selected	Installation output class standards	List of alphanumeric output classes, each separated by a comma	If CLASS is specified in the Work-selection criterion in the WS parameter, the FSA selects datasets that match values specified here.	
WS		Installation preferences (see note)	Work-selection criterion	Consider CL, R, and F. See Note below and JES3 Initialization and Tuning Reference manual for more information.	



Note: The WS parameter CL specifies that datasets with the same class as the WS parameter should be selected. D specifies that only datasets with the same destination as the DGROUP parameter should be selected. F specifies that JES3 is to pass the forms value specified on the DD or OUTPUT JCL statement to the FSA. □

Following is an example of the JES3 initialization dataset required commands:

Table E-4. JES3 initialization dataset commands example

```

FSSDEF          TYPE=WTR , FSSNAME=FSSTCP1 , PNAME=FSSPROC1 , SYSTEM=SYS1 , TERM=NO
DEVICE         DTYPE=PRTAFT1 , JNAME=PRT7 , JUNIT= ( , SYS1 , , OFF ) , FSSNAME=FSSTCP1 ,
              DGROUP=LOCAK , MODE=FSS , PM= ( LINE , PAGE , SOSI1 ) , WC= ( T ) , WS=CL , D , F
    
```

4. Configure the printer in PSF/MVS

Follow these steps to configure the IPS printer in PSF:

1. Locate the PSF startup procedure in the JES3 or JES2 startup JCL procedure. This is normally kept in SYS1.PROCLIB, although your system may use a different library.

The libraries specified by the //PROC00 DD statement normally contains startup procedures for PSF subsystems. The name of the procedure is specified in the initialization dataset (FSS statement PROC parameter in JES2; the FSSDEF statement PNAME parameter in JES3. See the appropriate section in this appendix for clarification).

2. Add a PRINTDEV statement to define the IPS printer in PSF. (See the example below for the general format or the *PSF Systems Programming Reference* for more information.

The table below contains descriptions of the PSF parameters which need to be set for the IPS printer.

Table E-5. **PSF/MVS PRINTDEV statement parameters**

Item description	Default	Source of value	Range of acceptable values	Comments	Your value
APPLID	None	VTAM APPL statement	1 to 8-character alphanumeric string	Not applicable for TCP/IP-attached printer	
BUFNO		N/A	5 to 100	Not applicable for TCP/IP-attached printer	
FAILURE		Installation preferences	WCONNECT or STOP	If IPS is used by other hosts, WCONNECT causes PSF to continuously retry to establish connection with printer.	
FDEFDD	None	Installation preferences	1 to 8-character alphanumeric string	Name of the form definition library DD statement	
FONTDD	None	Installation preferences	1 to 8-character alphanumeric string	Name of font library DD statement. Fonts in this library must match resolution the IPS is using.	
FORMDEF	None	Installation preferences	1 to 6-character alphanumeric string	Name of default FORMDEF for IPS printer	
IPADDR	None	Xerox IPS installation	Valid IP address in dotted decimal format, enclosed in quotes	Example: IPADDR='12.345.676.89'	
JOBHDR	None	Installation preferences	1 to 8-character alphanumeric string	Name of OUTPUT statement that defines form and page definition used to format job header separator pages	

Table E-5. PSF/MVS PRINTDEV statement parameters
(continued)

Item description	Default	Source of value	Range of acceptable values	Comments	Your value
JOBTRLR	None	Installation preferences	1 to 8-character alphanumeric string	Name of OUTPUT statement that defines form and page definition used to format job trailer separator pages	
LOGMODE		N/A		Not applicable for TCP/IP-attached printer	
LUNAME		N/A		Not applicable for TCP/IP-attached printer	
MESSAGE	None	Installation preferences	1 to 8-character alphanumeric string	Identifies OUTPUT statement that specifies form and page definitions used to format and print messages.	
MGMTMODE		Installation preferences	OUTAVAIL or DIALIN or IMMED	OUTAVAIL: Requests that PSF start a communication session with printer only when output is available on JES spool. DIALIN or IMMED: Requests that PSF start a communication session with this printer immediately. PSF then looks for output available on JES spool.	
NPRO		N/A		Not applicable to cut-sheet Xerox printers	
OBJCONDD		N/A		Not applicable for TCP/IP-attached printers	
OVLYDD	None			Name of font library DD statement. Fonts in this library must match the resolution the IPS is using.	
PAGEDEF	None			Name of default Page Definition for IPS printer	
PDEFDD	None			Name of Page Definition library DD statement	

Table E-5. **PSF/MVS PRINTDEV statement parameters**
(continued)

Item description	Default	Source of value	Range of acceptable values	Comments	Your value
PIMSG	(YES,16)	Installation preferences	(YES, <i>nnn</i>) or (NO, <i>nnn</i>)	YES: Specifies error messages are always printed. <i>nnn</i> : Specifies maximum number of messages groups generated before job is purged from spool. A value of 0 causes printer to print continuously, regardless of number of errors.	
PORTNO	5001	Xerox IPS Interface windows	Valid TCP/IP port number between 5001 and 32767	Applicable only to TCP/IP printers. (Ensure the chosen port number is not in TCP/IP list of reserved port numbers.)	
PSEGDD	None			Name of Page Segment library DD statement. For best results, the images in page segments in this library should match the resolution the IPS printer is using.	
SETUP	No Setup messages issued	Installation preferences	SETUP=FORMS if specified	If specified, causes JES to issue FORMS setup message when a job prints which has a FORMS specification different from job previously printed. This is recommended where there are multiple paper stocks for use on the IPS printer.	
RELINTV				Not applicable to Xerox cut-sheet printers	
RELMODE	None		IDLE, TIME, or NONE	Not applicable to Xerox cut-sheet printers	

Table E-5. PSF/MVS PRINTDEV statement parameters (continued)

Item description	Default	Source of value	Range of acceptable values	Comments	Your value
TIMEOUT		Installation preferences	REDRIVE or STOP	REDRIVE: When there is a time-out after period specified in DISCONTV parameter, REDRIVE requests that PSF attempt to drive the printer according to MGMTMODE specification. STOP: Forces operator to restart FSA. Note: REDRIVE is recommended for TCP/IP printers that may be shared with other hosts. □	
TRACE	NO		YES or NO	Should be used only for debugging PSF-related problems.	



Note: To specify a TCP/IP address space name other than the default (TCP/IP), code the following EXEC statement in the appropriate PSF writer procedure:

```
STEP01 EXEC PGM=APSPPIEP,
          PARM=(,,,,tcpip_name), REGION=4096K
```

where *tcp/ip_name* is the name of the TCP/IP address space.

If this parameter is not coded, PSF uses the default name, TCPIP. (For a full description of the PARM parameter, refer to *Print Services Facility/MVS: Diagnosis Guide and Reference*.) □

Table E-6. PSF/MVS PRINTDEV statement example

```

//PRT277 CNTL
//PRT277 PRINTDEV FONTDD=*.FONT01, /* FONT LIBRARY DD */
//      OVLYDD=*.OLAY01, /* OVERLAY LIBRARY DD */
//      IPADDR='13.240.160.97', /* PRINTER IP ADDRESS */
//      PORTNO=5005 /* PORT NUMBER */
//      PSEGDD=*.PSEG01, /* SEGMENT LIBRARY DD */
//      PDEFDD=*.PDEF01, /* PAGEDEF LIBRARY DD */
//      FDEFDD=*.FDEF01, /* FORMDEF LIBRARY DD */
//      JOBHDR=*.JOBHDR, /* JOB HEADER SEPARATOR OUTPUT */
//      JOBTRLR=*.JOBTLR, /* JOB TRAILER SEPARATOR OUTPUT */
//      DSHDR=*.DSHDR, /* DATA SET HEADER SEPARATOR */
//      MESSAGE=*.MSGDS, /* MESSAGE DATA SET OUTPUT */
//      BUFNO=29, /* NUMBER OF WRITE DATA BUFFERS */
//      PAGEDEF=X06483, /* DEVICE PAGEDEF DEFAULT */
//      FORMDEF=A10111, /* DEVICE FORMDEF DEFAULT @H3C*/
//      CHARS=(GT15, /* DEVICE */
//      GT12,GT18,GT24), /* DEFAULT FONT SET @H3C*/
//      PIMSG= (YES,999), /* ACCUMULATE DATA SET MESSAGES */
//      DATAK=BLOCK, /* BLOCK DATA CHECKS */
//      TRACE=NO /* BUILD INTERNAL TRACE @H3C*/
// PRT277 ENDCNTL

```

5. Configure TCP/IP for MVS for the printer

The TCP/IP Profile dataset contains statements that define the parameters used by TCP/IP for MVS address space. The following parameters have special consideration for PSF and the TCP/IP-attached IPS printers.



Note: It is not necessary to define the printer in TCP/IP for MVS, because the IPS acts as a conduit from the MVS system to the LAN. However, some settings in the TCP/IP Profile dataset may need to be altered, depending on your current settings. □

Table E-7. TCP/IP Profile dataset parameters – MVS

Item description	Default	Source of value	Range of acceptable values	Comments	Your value
DATABUFFERPOOLSIZ Data buffers	160	Installation preferences	7 to nnnn, where nnnn is limited by available virtual storage	Specify at least 160 buffers.	
DATABUFFERPOOLSIZ Buffer size	16384	Installation preferences	8192 49152 12288 65536 16384 98304 24576 131072 28672 196608 32768 262144	Specify a buffer size of at least 32768, if possible.	
SMALLDATABUFFERPOOLSIZ	0	Installation preferences	0 to nnnn, where nnnn is limited by available virtual storage	Specify at least 256 small data buffers.	
TINYDATABUFFERPOOLSIZ	0	Installation preferences	0 to nnnn, where nnnn is limited by available virtual storage	Specify at least 256 tiny data buffers.	
KEEPALIVEOPTIONS	Interval 120 sendgarbage false	Installation preferences		See Notes.	
GATEWAY max_packet_size	Defaultsize is 576	Installation preferences	Can be from 576 to 67108864, but cannot be larger than value specified on LARGEENVE LOPEPOOLSIZ statement.	Max packet size parameter should be no greater than 4472 bytes in a 4 Mbps LAN configuration, and 17800 in a 16 Mbps LAN configuration. Default MTU value in IPS printer is 2052.	

Considerations for configuring TCP/IP for MVS

Following are some considerations for configuring TCP/IP for MVS:

- To specify a TCP/IP address space name other than the default, TCPIP, code the following EXEC statement in the appropriate PSF writer procedure:

```
STEP01 EXEC PGM=APSPPIEP,
        PARM=(,,,,tcpip_name), REGION=4096K
```

where *tcpip_name* is the name of the TCP/IP address space.

If this parameter is not coded, PSF uses the default name, TCPIP. (For a full description of the PARM parameter, refer to *Print Services Facility/MVS: Diagnosis Guide and Reference*.)

- KEEPALIVEOPTIONS statement:** PSF relies on TCP to detect when a connection with the IPS printer is no longer usable. When no data has been exchanged between PSF and its connection partner, TCP sends keep-alive probes to the connection partner periodically. These periodic probes, called keep-alive transmissions, enable TCP to discover when a connection is no longer usable, even if the connection partner is abruptly powered off or is no longer accessible through the network.

The frequency of keep-alive transmissions is controlled by the INTERVAL parameter on the KEEPALIVEOPTIONS statement. The frequency applies to all TCP applications that direct TCP to send keep-alive transmissions. The default frequency is after about two hours of inactivity.

For printing on the IPS, it is recommended you specify a shorter interval than the default—such as 10 minutes—for the interval between keep-alive transmissions. Also, unless any target host requires that the keep-alive packet contain data, specify SENDGARBAGE FALSE. For example:

```
KEEPALIVEOPTIONS INTERVAL 10 SENDGARBAGE FALSE
ENDKEEPALIVEOPTIONS
```

If you change any of the values in the TCP/IP profile, restart TCP/IP to pick up the changes.

Table E-8. **TCP/IP Profile dataset statements example – MVS**

ACBPOOLSIZE		1000				
ADDRESSTRANSLATIONPOOLSIZE		1500				
CCBPOOLSIZE		150				
DATABUFFERPOOLSIZE		160	32768			
ENVELOPEPOOLSIZE		750				
IPROUTPOOLSIZE		300				
LARGEENVELOPEPOOLSIZE		50				
RCBPOOLSIZE		50				
SCBPOOLSIZE		256				
SKCBPOOLSIZE		256				
SMALLDATABUFFERPOOLSIZE		256				
TCBPOOLSIZE		512				
TINYDATABUFFERPOOLSIZE		256				
UCBPOOLSIZE		100				
KEEPALIVEOPTIONS	INTERVAL	10	SENDGARBAGE	TRUE		
ENDKEEPALIVEOPTIONS						
GATEWAY						
	; * Network	First hop	Linkname	Packet size	Subnet mask	Subnet value
	9	=	BPCLAN	2000	0.255.255.0	0.99.12.0
	DEFAULTNET	9.99.12.254	BPCLAN	2000	0.255.255.0	0

References: For information about the TCP/IP profile and the statements described in this section, refer to the following publications:

- TCP/IP for MVS: Customization and Administration Guide*
- TCP/IP: Performance Tuning Guide*

6. Test the printer to ensure it prints from the MVS host

Test the printer by one of the following methods:

- Send a job from the host through PSF to print on the IPS. (Refer to your *IPS Guide to Configuring and Managing the System* for printing procedures.)
- Ping the printer from your MVS host to ensure MVS can establish a connection with the TCP/IP-attached IPS.

Pinging the printer – MVS

To ping the printer from the MVS host, enter one of the following commands:

- **In JES3:** At your MVS host, enter the following command at the TSO prompt:

TSO PING *ip-address*

- **In JES2:** Enter the following command from the System Display and Search Facility (SDSF), menu 6:

ping *ip-address*

ip-address specifies the internet protocol (IP) address of the IPS printer.

If the ping is successful:

Table E-9. **Example of a successful ping – MVS**

```
EZA0458I Ping V3R1: Pinging host 9.99.12.33
      (Use ATTN to interrupt)
EZA 0463I PING: Ping #1 response took 0.084 seconds.
Successes so far = 1.
```



Note: A successful ping usually indicates that the MVS system can communicate with the IPS. However, you could receive a successful ping even if the IP address of the TCP/IP-attached printer is a duplicate of another IP address. □

If PSF is unable to establish a network connection with the TCP/IP-attached IPS, or if PSF output for this printer prints elsewhere, follow these steps to determine whether the IP address of the printer is unique:

1. Power off the printer.
2. Wait at least five minutes for TCP/IP to clear the Address Resolution Protocol (ARP) tables.



Note: If your installation specified a longer interval on the ARPAGE configuration statement in the TCP/IP profile, you may need to wait longer than five minutes. (For information about the ARPAGE statement, refer to the *IBM TCP/IP MVS Customization and Administration Guide*.) □

3. Enter the ping command again at the MVS system.

If you receive a successful response to the ping command this time, it means there is a duplicate IP address. Consult your network administrator.

If the ping is unsuccessful:Table E-10. **Example of an unsuccessful ping – MVS**

```
EZA0458I Ping V3R1: Pinging host 9.99.12.33
(Use ATTN to interrupt)
EZA 0464I PING: Ping #1 timed out
```

If your ping is not successful, verify the following:

- The printer is powered on.
- The cables are properly connected between the printer and the LAN.
- The Network Interface Card (NIC) in the printer is functioning properly. (Consult your Xerox service representative.)
- There is proper connectivity to the Multi-station Access Unit (MAU), if one is being used.
- The IP address used to define the printer in PSF is unique in the TCP/IP network.
- The IP address of the MVS system is unique. If not, consult your network administrator to resolve the address problem.
- The Maximum Transmission Unit (MTU) size of the IP packet for the MVS system is equal to the MTU size of the printer. (For information about the values recommended for the MVS system, see the “GATEWAY” statement in table B-8.)
 - To change the MTU size for the MVS system, change the GATEWAY statement in the MVS TCP/IP profile, and restart TCP/IP to activate the changes.
 - If you are running RouteD, the maximum MTU size is the one specified on the BSDROUTINGPARMS statement (MTU).
 - The default MTU value in the IPS printer is 2052. To change the MTU size for the printer, refer to the Sun network software documentation.
 - If these items are all in order, consult your network administrator about a possible network problem.

Correcting for printer performance issues – MVS

Should you notice any printer performance problems—e.g., throughput speed degradation, check the areas listed in the following table.

Table E-11. **Components to check for printer performance problems**

MVS	On the MVS system, ensure that both the PSF and TCP/IP address spaces are receiving a high level of service, are at a high dispatching priority, and their datasets and the JES2 spool datasets are on DASD volumes that have low competing activity from other applications and from other DASD volumes on the same path.
Printer	Ensure that the Maximum Transmission Unit size (MTU) is as large as possible. A small MTU size increases the number of packets that are transmitted, allowing greater chances of degradation throughout the network. Increasing the MTU size in both TCP/IP for MVS and in the IPS printer may improve printer performance.
LAN	If the printer is on a LAN that also has a large number of other devices attached to it, the high levels of traffic on the LAN can cause printer speed degradation. Consider moving the printer to a LAN that does not have so much activity on it.
LAN-to-host attachment	If the speed of the link connecting the LAN with the printer attached to the MVS system is slow, this could be a bottleneck. This could be a concern with any configuration in which the LAN-attached controller (i.e., 3745, 3172, or 3174) is not directly channel-attached to the host running PSF. This could occur in a Remote LAN configuration as discussed in the Network Configurations section, earlier in this chapter. Review your network configuration diagrams to look for any potential bottlenecks.

References

The following IBM documents, referenced in this section, can provide additional information on MVS-to-IPDS printer connectivity.

Table E-12. **MVS reference documentation**

Title	Publication number
<i>MVS Collection Online Library Omnibus Edition</i>	SK2T-0710
<i>OS/390 HCD Planning or MVS/ESA Migration Planning: Dynamic I/O Configuration</i>	GC28-1445
<i>OS/390 HCD User's Guide or MVS/ESA Hardware Configuration: Using the Dialog</i>	SC33-6468
<i>Print Services Facility/MVS: Diagnosis Guide and Reference</i>	G544-5462
<i>Print Services Facility/MVS: System Programming Guide</i>	S544-3673
<i>TCP/IP for MVS: Customization and Administration Guide</i>	SC31-7134
<i>TCP/IP for MVS: Performance Tuning Guide</i>	SC31-7188
<i>MVS/ESA SP V5 JES2 Initialization and Tuning Guide</i>	SC28-1453
<i>MVS/ESA SP V5 JES2 Initialization and Tuning Reference</i>	SC28-1454
<i>MVS/ESA JES2 Initialization and Tuning</i>	SC28-1038
<i>MVS/ESA JES3 Initialization and Tuning</i>	SC23-0073
<i>MVS/ESA SP V4 JES3 Initialization and Tuning Reference</i>	SC23-0089
<i>MVS/ESA SP V5 JES3 Initialization and Tuning Guide</i>	SC28-1455
<i>MVS/ESA SP V5 JES3 Initialization and Tuning Reference</i>	SC28-a456

AS/400 parameters

This section describes the process of configuring an AS/400 system to communicate and print on an IPS using TCP/IP. This process is applicable to either a Token Ring or an Ethernet LAN. (Ethernet connectivity is a future option for IPS.)

This information applies to all AS/400 RISC models with OS/400 V3R7 (or higher) installed. Some references are made to OS/400 V3R2 installed CISC models.

Software prerequisites – AS/400

The following prerequisite software packages must be installed on your host system before you begin the configuration process described in the following pages. Ensure that you are using the manuals for the proper software releases.

Table E-13. **AS/400 software prerequisites**

OS/400	Licensed program	Description	Product option
V3R7	5716TC1	TCP/IP Connectivity Utilities for AS/400	*BASE
V3R7	5716SS1	OS/400—Print Services Facility/400	N/A
V3R2	5763TC11	TCP/IP Connectivity Utilities/400	N/A
V3R2	5763AF1	Advanced Function Printing Utilities/400	N/A
V3R2	5763SS1	OS/400—Print Services Facility/400	N/A

Network configurations – AS/400

The IPS printer is supported in all the following types of AS/400 configurations, provided that the software prerequisites are installed.

- Basic configuration in which the AS/400 is attached to a LAN using either a Token Ring or Ethernet network adapter card
- Remote LAN environment in which there are data communication links between the AS/400 and the LAN-attached controller
- Configurations in which the LAN with the printer attached is connected to the host-attached controller using LAN devices such as routers.



Note: There may be printer performance and throughput implications with some of these configurations. It is recommended that your network management group be involved with planning this installation. □

Configuration steps – AS/400

Follow these steps to configure your AS/400 to print to an IPS printer connected to the LAN, using TCP/IP.

Configuration worksheet The following worksheet will help you in planning the IPS installation. It describes the key values which you need to supply when planning the AS/400 configuration. All values on this worksheet must be determined before you begin the printer configuration on the host.

Table E-14. **AS/400 configuration worksheet for IPS**

Item description	Also known as...	Source	Your value
Device description	DEV D	This is the name of the printer (writer). An Output Queue of the same name is automatically created. Spool files that you place in this Output Queue are directed to the printer.	
Remote location	RMTLOCNAME	Xerox IPS software installation. This is the printer IP address.	
Port number	PORT	IPS configuration Interface window and subwindows. The value 5001 works best for IPDS printers.	
PSF configuration	PSFCFG	Same as Device description	



Note: It is assumed that your AS/400 is connected to the LAN and all the prerequisite software is installed and configured.

1. Configure the IPS printer for TCP/IP at the GUI

Refer to your *IPS Guide to Configuring and Managing the System*, chapter 4, "Setting the system configuration," for this graphical user interface (GUI) procedure to specify the TCP/IP interface.

2. Create the PSF/400 configuration

Follow these steps to configure PSF/400 for the IPS printer.

1. At the AS/400, press <F4> to prompt the CRTPSFCFG command.
2. Key in the parameter values as indicated in the figure below. For parameters with  * beside them, refer to the configuration worksheet, earlier in this section.

Table E-15. Create PSF Configuration screen – AS/400

Create PSF Configuration (CRTPSFCFG)		
Type choices, press Enter.		
PSF configuration.....	> XEROXIPS	<input type="checkbox"/> *
Library.....	> QGPL	
User resource library list.	*JOBLIBL	
Device resource library list....	*DFT	
	+ for more values	
IIPDS pass through.....	*NO	
Activate release time.....	*NORDYF	
Release time.....	> *SEC15	
Restart timer.....	> *IMMED	
SNA retry count.....	2	
Delay time between SNA retries..	0	
Text 'description'.....	*BLANK	
Additional parameters....		
Blank page.....	*YES	
Page size control.....	*NO	
Resident font.....	*NO	
Resource retention.....	*YES	
Edge orient.....	*NO	
Remote location:		
Name or address.....	> '9.9.999.999'	<input type="checkbox"/> *
TCP/IP port.....	> 5001	<input type="checkbox"/> *
TCP/IP activation timer...	170	

3. Create the printer device description – AS/400

Follow these steps to create the device description for the IPS printer.

1. At the AS/400, press <F4> to prompt the CRTDEVPRT command.
2. Key in the parameter values as indicated in the appropriate figure below.
 - Table E-16 shows printer description parameters for OS/400 with V3R7 installed.
 - Table E-17 shows parameters for OS/400 with V3R2 installed.

For parameters with * beside them, refer to the configuration worksheet, earlier in this section.

Table E-16. Create Device Description (Printer) screen for OS/400 with V3R7 installed

```

CREATE DEVICE DESC (PRINTER) (CRTDEVPRT)

Type choices, press Enter.

DEVICE DESCRIPTION..... > XEROXIPS      ◀ *
DEVICE CLASS.....        > *LAN          (New to V3R7)
DEVICE TYPE.....         > *IPDS
DEVICE MODEL.....        > 0
LAN ATTACHMENT.....      *IP              (New to V3R7)
ADVANCED FUNCTION PRINTING.. *YES
PORT NUMBER.....         > 5001      ◀ *
ONLINE AT IPL.....       *YES

FONT:
  IDENTIFIER.....        > 11
  POINT SIZE.....        *NONE
FORM FEED.....           *TYPE
SEPARATOR DRAWER.....    *FILE
SEPARATOR PROGRAM.....    *NONE
  LIBRARY.....
PRINTER ERROR MESSAGE..... *INQ
MESSAGE QUEUE.....       QSYSOPE
  LIBRARY.....           *LIBL
ACTIVATION TIMER.....     170
MAXIMUM PENDING REQUESTS... 6
PRINT WHILE CONVERTING.... *YES
PRINT REQUEST TIMER.....  *NOMAX
FORM DEFINITION
  LIBRARY.....           *LIBL
REMOTE LOCATION:
  NAME OR ADDRESS.....    9.9.999.999   ◀ *
REMOTE NETWORK IDENTIFIER... *NETATR
WORKSTATION CUSTOMIZING OBJECT
  LIBRARY.....
USER-DEFINED OBJECT:
  OBJECT.....            > XEROXIPS      ◀ * Same as PSF
  LIBRARY.....           > QGPL          configuration
  OBJECT TYPE.....       > *PSFCFG
DATA TRANSFORM PROGRAM.... *NONE
  LIBRARY.....
TEXT 'DESCRIPTION'.....   *BLANK

```

Table E-17. Create Device Description (Printer) screen for OS/400 with V3R2 installed

```

CREATE DEVICE DESC (PRINTER) (CRTDEVPRT)

Type choices, press Enter.

DEVICE DESCRIPTION..... > XEROXIPS      ◀ *
DEVICE CLASS.....        > *RMT
DEVICE TYPE.....         > *IPDS
DEVICE MODEL.....        > 0
ADVANCED FUNCTION PRINTING.. *YES
AFP ATTACHMENT.....      > *APPC
MESSAGE QUEUE.....       QSYSOPE
    LIBRARY.....          *LIBL
MAXIMUM PENDING REQUESTS... 6
PRINT WHILE CONVERTING..... *YES
PRINT REQUEST TIMER.....    *NOMAX
FORM DEFINITION.....       F1C10110
    LIBRARY.....          *LIBL
REMOTE LOCATION.....      XEROXIPS      ◀ * Same as DEVICE
LOCAL LOCATION.....       *NETATR              DESCRIPTION
REMOTE NETWORK IDENTIFIER... *NETATR
MODE.....                 *NONE
TEXT 'DESCRIPTION' .....  *BLANK
    
```

4. Test the printer connection – AS/400

Test the printer by one of the following methods to ensure AS/400 is able to make a connection with the IPS printer:

- Send a job from the host through PSF to print on the IPS. (Refer to your IPS *Guide to Configuring and Managing the System* for printing procedures.)
- Ping the printer from your AS/400 system to ensure the AS/400 can establish a connection with the TCP/IP-attached IPS.

Pinging the printer

To ping the printer to verify a connection can be made, enter the following command on an OS/400 command line:

PING 'Remote Location'

'remote location' specifies the internet protocol (IP) address of the IPS printer (refer to the configuration worksheet, earlier in this section).

If the ping is successful:Table E-18. **Example of a successful ping – AS/400**

```
ping 9.9.999.999
Verifying connection to host system LOOPBACK at address 9.9.999.999.
Connection verification 1 took .000 seconds. 1 successful connection
verifications.
Connection verification 2 took .000 seconds. 2 successful connection
verifications.
Connection verification 3 took .001 seconds. 3 successful connection
verifications.
Connection verification 4 took .000 seconds. 4 successful connection
verifications.
Connection verification 5 took .000 seconds. 5 successful connection
verifications.
Round-trip (in milliseconds) min/avg/max = 0/0/1
Connection verification statistics: 5 of 5 successful (100 %).
```



Note: A successful ping usually indicates that the AS/400 system can communicate with the IPS. However, you could receive a successful ping even if the IP address of the TCP/IP-attached printer is a duplicate of another IP address. □

If PSF output for this printer prints elsewhere, follow these steps to determine whether the IP address of the printer is unique:

1. Power off the printer.
2. Wait at least five minutes for TCP/IP to clear the Address Resolution Protocol (ARP) tables.
3. Enter the ping command again at the AS/400 system.
4. If you receive a successful response to the ping command this time, there is a duplicate IP address. Consult your network administrator. □

If the ping is unsuccessful:Table E-19. **Example of an unsuccessful ping – AS/400**

```
ping 9.9.999.999
Verifying connection to host system TEST at address 9.9.999.999.
No response from host within 10 seconds for connection verification 1.
No response from host within 10 seconds for connection verification 2.
No response from host within 10 seconds for connection verification 3
No response from host within 10 seconds for connection verification 4.
No response from host within 10 seconds for connection verification 5.
Connection verification statistics: 0 of 5 successful (0 %).
```

If your ping is not successful, verify the following:

- The printer is powered on.
- TCP/IP has been started on the AS/400 (command: **STRTCP**).
- The cables are properly connected between the printer and the LAN.
- The Network Interface Card (NIC) in the printer is functioning properly. (Consult your Xerox service representative.)

- There is proper connectivity to the Multi-station Access Unit (MAU), if one is being used.
- The IP address used to define the printer in PSF is unique in the TCP/IP network.
- The IP address of the AS/400 system is unique. If not, consult your network administrator to resolve the address problem.

Correcting for printer performance issues – AS/400

Should you notice any printer performance problems—e.g., throughput speed degradation, check the areas listed in the following table.

Table E-20. **Components to check for printer performance problems**

LAN	If the printer is on a LAN that also has a large number of other devices attached to it, the high levels of traffic on the LAN can cause printer speed degradation. Consider moving the printer to a LAN that does not have so much activity on it.
AS/400 to LAN attachment	If the speed of the link connecting the LAN with the printer attached to the AS/400 system is slow, this could be a bottleneck. Review your network configuration diagrams to look for any potential bottlenecks.

References – AS/400

The following IBM documents, referenced in this section, can provide additional information on AS/400-to-IPDS printer connectivity.

Table E-21. **Reference documents – AS/400**

Title	Publication number
<i>AS/400 Guide to AFP and PSF</i>	S544-5319
<i>OS/400 Printer Device Programming V3R7</i>	SC41-4713
<i>OS/400 TCP/IP Configuration and Reference V3</i>	SC41-3420
<i>OS/400 Work Management V3R7</i>	SC41-4306
<i>AS/400 Printing IV</i>	GG24-4389

AIX parameters

This section provides information on using TCP/IP to attach an IPS printer to an RS/6000 in an AIX environment using PSF/6000 or InfoPrint Manager. The following information is applicable to an IPS attached to either a Token Ring or Ethernet LAN.

Software prerequisites – AIX

In order to print on a TCP/IP-attached IPS printer directly through PSF on an RS/6000 AIX system, you must have the **PSF for AIX version 2.1** software or **InfoPrint Manager for AIX version 3.1** software.

It is necessary for this software to be installed on the system before you begin the configuration process described in this section. Make sure that you are using the manuals for this software release.



Note: IBM recommends that you apply the latest program temporary fixes (PTF) to your system for IPDS printing. These PTFs are available from IBM's website. Depending on which PSF options have been installed on your system, you may wish to apply the latest PTFs before installing your IPS. The PTF images for PSF/AIX are all cumulative fixes—the latest PTFs for a product include all previously released PTFs also. 

Program temporary fixes (PTFs)

The PTFs for the entire PSF/AIX product suite are available at the following IBM website:

[ftp.software.ibm.com/printers/products/psfaix/fixes/](ftp://software.ibm.com/printers/products/psfaix/fixes/)

The PTFs for the entire InfoPrint Manager product suite are available at the following IBM website:

[ftp.software.ibm.com/printers/products/infoprint/fixes/](ftp://software.ibm.com/printers/products/infoprint/fixes/)

Be sure to view the readme files provided at these sites. They describe what is in the PTFs and how to apply them.

For further information about PTFs, see the following IBM website, which allows you search for PTFs and read about the APARs addressed in each PTF.

www.aix.can.ibm.com/aix.ca/support

Network configurations – AIX

The IPS printer is supported in the following types of RS/6000 with AIX configurations, provided that the network is configured properly and the software prerequisites are installed.

- Basic configuration in which the RS/6000 running AIX and PSF for AIX is attached to a LAN using either a Token Ring or Ethernet network adapter. The printer is attached to the same segment or ring.
- Configurations in which the LAN with the printer attached is connected to the LAN where the RS/6000 print server is attached, using LAN devices such as routers.



Note: There may be printer performance and throughput implications with some of these configurations. Your network management group should be involved in planning this installation. 

Configuration steps—AIX

This section provides references to detailed information on configuring an IBM RS/6000 system to print to an IPS printer using a TCP/IP LAN connection.

PSF/6000

For detailed information on configuring PSF/6000 so it recognizes your TCP/IP-attached printer, refer to Part 2, “Installing and Configuring PSF for AIX” in the *IBM Print Services Facility for AIX: Print Administration* manual (#S544-3817). This manual is available in PDF format at the following IBM website:

<http://www.printers.ibm.com/R5PSC.NSF/Web/manuals/opsevm>

InfoPrint Manager

For detailed information on configuring InfoPrint Manager so it recognizes your TCP/IP-attached printer, refer to Part 2, “Expanding Your InfoPrint System” in the *IBM InfoPrint Manager for AIX: Administrator's Guide* (#S544-5595). This manual is available in PDF format at the following IBM website:

<http://www.printers.ibm.com/R5PSC.NSF/Web/manuals/infprtm>

References

The following documents can provide additional information on AIX-to-IPDS printer connectivity.

Table E-22. Reference documents for AIX

Title	IBM order number
<i>IBM Print Services Facility for AIX: AIX for Users of Print Services Facility</i>	G544-3877
<i>IBM Print Services Facility for AIX: Print Administration</i>	S544-3817
<i>IBM Print Services Facility for AIX: Print Submission</i>	S544-3878
<i>IBM InfoPrint Manager for AIX: Administrator's Guide</i>	S544-5595
<i>IBM InfoPrint Manager for AIX: User's and Operator's Guide</i>	S544-5596
<i>IBM InfoPrint Manager for AIX: Reference</i>	S544-5475
<i>AFP Conversion and Indexing Facility: User's Guide</i>	S544-5285
<i>TCP/IP Network Administration</i> by Craig Hunt; O'Reilly & Associates, 1998	ISBN 1565923227
<i>AIX Performance Tuning</i> by Frank Waters; Prentice Hall, 1996	ISBN 0133867072
<i>The AIX Survival Guide</i> by Andreas Siegert; Addison Wesley, 1996	ISBN 0201593882

IBM Print Services Facility for AIX manuals are available in PDF format at the following IBM website:

<http://www.printers.ibm.com/R5PSC.NSF/Web/manuals/opsevm>

IBM InfoPrint Manager for AIX manuals are available in PDF format at the following IBM website:

<http://www.printers.ibm.com/R5PSC.NSF/Web/manuals/infprtm>

OS/2 parameters

This section describes the process and parameters to configure an OS/2 system to communicate with and print to your IPS printer using TCP/IP. This information applies both to Token Ring and Ethernet LANs.

Software prerequisites – OS/2

In an OS/2 system, in order to print on a TCP/IP-attached IPS directly through PSF, you need the following software:

- OS/2, Version 2.11 or higher
- PSF/2, Version 2.00 or higher
- TCP/IP For OS/2, Version 2.0 or higher

The following may be required, depending on your PSF/2 configuration:

- Communication Manager/2, Version 1.0 or higher
- DB2/2, Version 2.0 or higher
- IBM LAN Server, Version 3.0 or higher
- Novell Netware, version 3.11 or higher

You must have these prerequisites installed before beginning the configuration process. Ensure that you are using the manuals for the correct software releases.



Note: Installation of these products, and configuration activities not directly related to the IPS, are not discussed in this section. □

Network configurations – OS/2

The IPS printer is supported in all the following configurations, provided that the software prerequisites are installed.

- Basic configuration in which the host computer running OS/2 is attached to a LAN using a standard Token Ring or Ethernet network adapter card
- Remote LAN environment in which there are data communication links between the host and the LAN-attached controller
- Configurations in which the LAN with the printer attached is connected to the host-attached controller using LAN devices such as routers.



Note: There may be printer performance and throughput implications with some of these configurations. It is recommended that your network management group be involved with planning this installation. □

Configuration steps – OS/2

This section describes the process for configuring a TCP/IP attached host computer with OS/2 to print on an IPDS printer such as your IPS.

Configuration worksheet The following worksheet will help you in planning the IPS installation. It describes the key values which you need to supply when planning the OS/2 configuration. All values on this worksheet must be determined before you begin the printer configuration on the host.

Table E-23. **OS/2 configuration worksheet for IPS**

Item description	Also known as...	Source	Your value
Device Name		PSF/2 Control Panel—Define Device	
Device Description		PSF/2 Control Panel—Define Device	
Device Resolution	DPI, Pels per inch	PSF/2 Control Panel—Define Device	
Attachment Type	Printer Protocol	PSF/2 Control Panel—Define Device	TCP/IP
IP Address	TCP/IP Address IPADDR	Xerox NPS Printer software installation. PSF/2 Control Panel—Attachment Type Settings	
TCP/IP Port Number	PORTNO	IPS configuration Interface window and subwindows PSF/2 Control Panel—Attachment Type Settings	
Connect Timeout	Device Busy Time	PSF/2 Control Panel—Define Device	
Max Transmission Unit	MTU Max packet size MAXMTU	OS/2 TCP/IP Configuration (TCPIPCFG) Xerox NPS printer installation	
Queue Name		PSF/2 Control Panel—Define Queue	
Queue Description	OS/2 Printer Queue Name	PSF/2 Control Panel—Define Device	
Device Busy Time (Optional)	Connect time-out	PSF/2 Control Panel—Printer Definition	

1. Configure the printer for TCP/IP in OS/2

Configure your IPS for TCP/IP. (Refer to your IPS Guide to Configuring and Managing the System, chapter 4, “Setting up the Printer Controller.”)

2. Provide TCP/IP routing information if necessary

TCP/IP routing information is needed for remote LAN configurations only. (Refer to your host computer documentation for procedures, if needed.)

3. Define the printer to PSF/2

Follow these steps to define the IPS printer to PSF/2.

1. Select the Control Panel icon from the PSF/2 folder (located on the OS/2 Desktop).
2. From the Control Panel Main window, click on the Profile pulldown menu.
3. Select New from the Profile menu. The New device dialog window appears.
4. Enter all your new device parameter values in the fields that appear on this window.
5. Select the Settings button in the "Attachment Type" frame. The TCP/IP Settings window appears.
6. Enter the IP Address, TCP/IP Port Number, Form Definition, and Connect Timeout values on the TCP/IP Settings window.

The table below gives defaults, descriptions, and recommended values for the parameters accessible from the New Device and TCP/IP Settings windows.

Table E-24. **Parameters for PSF/2 device definition**

Item description	Default	Source of value	Acceptable range	Comments	Your value
Device Name	None	Your choice	Arbitrary, but special considerations if it matches an OS/2 device name	You will refer to the printer by this name in later PSF/2 activities. If you use LPT1, LPT2, or LPT3 (and they are not already being otherwise used) you are able to use the OS/2 commands PRINT, TYPE, and COPY with the IPS printer.	
Device Description	None	Your choice		Appears in Control Panel Main window.	
Attachment type		Required		If TCP/IP does not appear an available attachment type, either TCP/IP for OS/2 or the TCP/IP Attachment Support in PSF/2 has not been installed. (Refer to the appropriate IBM installation guide for details.)	TCP/IP

Table E-24. **Parameters for PSF/2 device definition** (continued)

Item description	Default	Source of value	Acceptable range	Comments	Your value
IP address	None	IPS printer installation	Address configured during the IPS installation.	A name can be entered if the TCP/IP network administrator appropriately configures the OS/2 HOSTS file or an appropriate domain name server. Can be alphabetic name (e.g., DNS) if network is so configured.	
TCP/IP Port number	5001	IPS UI configuration Interface window and subwindows	Valid TCP/IP port number between 5001 and 32767.	Applicable only to TCP/IP printers. Ensure chosen port number is not in the TCP/IP list of reserved port numbers.	
Form definition		Your choice	See online Help.	See your host computer's online Help for sample forms definitions.	
Connect timeout	30 secs.	Your choice	0 to 65535	This is the number of seconds PSF/2 will spend attempting to contact the IPS printer. A value of 0 causes PSF/2 to keep trying indefinitely.	
Device Resolution		Xerox IPS printer installation	240 or 300	Resolution of printer as set during IPS printer installation (used when printing OS/2 metafile77+s)	

7. Select Create. An entry representing the IPS is created within the PSF/2 Control Panel Main window.

4. Define a PSF/2 print queue for the printer (optional)

You may define a PSF/2 queue for the IPS, using the PFT/2 Control Panel. (You must complete step 3—defining the IPS printer to PSF/2—before starting this step.)

1. From the PSF/2 Control Panel main window, select the entry for the IPS (created in step 3).
2. On the Control Panel Main window, select the Options menu button.
3. From the Options menu, select "Setup queues." The Setup Queues window appears.
4. On the Setup Queues window, enter your values for the parameters displayed there. The following table describes those parameters.

Table E-25. Parameters for PSF/2 device definition

Item description	Default	Source of value	Comments	Your value
Queue Name	None	Your choice	Internal name of queue	
Queue Description	None	Your choice	Appears under the icon on the OS/2 Desktop as the name of the IPS printer queue.	

5. Ensure that the Device name selected on the Device list is the IPS printer you defined previously.
6. Select Setup. The printer queue is created on the OS/2 desktop.
7. To make this queue available to other users on the LAN, follow the procedures documented in either the *Installation Cookbook for AS/400* or the *Installation Cookbook for S/370*.



Note: Once the OS/2 Printer Queue object has been created on the Desktop, do not attempt to alter its values using its Settings dialog. Return to the PSF/f2 folder and the Control Panel to make any necessary changes. □

5. Test the printer connection in OS/2

Test the printer by one of the following methods to ensure OS/2 can make a connection with it:

- Ping the printer from your OS/2 system to ensure the OS/2 can establish a connection with the TCP/IP-attached IPS.
- To verify that the OS/2 system can pass output to the printer, send a short ASCII text file from the host through PSF to print on the IPS. (Refer to your IPS *Guide to Configuring and Managing the System* for printing procedures.)

Pinging the printer – OS/2

To ping the printer, enter the following command on an OS/2 command line:

PING ip-address

ip-address specifies the internet protocol (IP) address of the IPS printer (refer to the configuration worksheet, earlier in this section).

If your ping is successful:

Table E-26. Example of a successful ping – OS/2

```
EZA0458I Ping V3R1: Pingging host 9.99.12.33
      (Use ATTN to interrupt)
EZA0463I PING: Ping #1 response took 0.084 seconds.
Successes so far = 1.
```



Note: A successful ping usually indicates that the OS/2 system can communicate with the IPS. However, you could receive a successful ping even if the IP address of the TCP/IP-attached printer is a duplicate of another IP address. □

If PSF/2 output for the IPS prints elsewhere:

Follow these steps to determine whether the IP address of the printer is unique.

1. Power off the printer.
2. Wait at least five minutes for TCP/IP to clear the Address Resolution Protocol (ARP) tables.
3. Enter the ping command again at the OS/2 system.
4. If you receive a successful response to the ping command this time, there is a duplicate IP address. Consult your network administrator. □

If the ping is not successful:Table E-27. **Example of an unsuccessful ping – OS/2**

```
EZA0458I Ping V3R1: Pinging host 9.99.12.33
      (Use ATTN to interrupt)
EZA0463I PING: Ping #1 timed out.
```

If your ping is not successful, verify the following:

- The printer is powered on.
- The cables are properly connected between the printer and the LAN.
- The Network Interface Card (NIC) in the printer is functioning properly. (Consult your Xerox service representative.)
- There is proper connectivity to the Multi-station Access Unit (MAU), if one is being used.
- The IP address used to define the printer in PSF is unique in the TCP/IP network.
- The IP address of the OS/2 system is unique. If not, consult your network administrator to resolve the address problem.

Printing a test job

To print a file to test the IPS printer, follow these steps:

1. Enter the following command on an OS/2 command line:

APRINT *asciifile* DESTINATION=*xeroxdev*

where *asciifile* is the name of the test file to be printed (e.g., C:CONFIG.SYS), and *xeroxdev* is the queue name specified for the PSF/2 queue definition.

2. If an error message is generated, attempt to ascertain the reason for the error.
3. If garbage is produced at the printer, verify that only valid device transforms have been defined, and that the printer options do not contain an illegal ASCII initialization string.
4. Verify that the file to be printed is ASCII text and does not contain control characters, which may cause unexpected changes in the printer state.
5. If no output is generated, check the following items:
 - The file you are attempting to print exists.
 - You have specified the correct queue name on the APRINT command.

- The OS/2 TCP/IP stack has been initialized (usually done during system bootup). The TCP/IP NETSTAT command has several options which may reveal network problems.
 - The OS/2 queue is not in a “Hold” state.
 - A data stream is arriving at the IPS. The IPS Printer Control Unit status on the IPS user interface screen should go from “idle” to “receiving” during reception of the data stream. If it does not, verify that the correct IP address and TCP/IP Port Number are specified to both PSF/2 and the printer.
6. You may examine the contents of the spool queue by opening the queue object on the OS/2 desktop. An entry should appear during the execution of APRINT, then change to a status of “Printing” before disappearing from the queue.

If OS/2 detects an error during printing, the entry is held in the queue with an appropriate status indicating the error. If the entry never changes status to “Printing,” either the queue or the entry is in a “Hold” state, or OS/2 is unable to contact the printer to initiate printing.

If the entry enters a “Printing” state then disappears, but no output was produced on the IPS printer, check to see if the output was printed elsewhere. This would indicate a definition in either TCP/IP or PSF/2 that is incorrect, but still happens to match the device where the output appeared.

Correcting for printer performance issues – OS/2

Should you notice any printer performance problems—e.g., throughput speed degradation, check the areas listed in the following table.

Table E-28. **Components to check for printer performance problems – OS/2**

OS/2	<p>On the OS/2 system, a system-changeable priority controls the resources allocated to printing activities. By default this is set to a median value, representing the relatively low priority printing has on a typical desktop system. In the case of a print server, it may be appropriate to increase this value to favor printing over any other activities that may be going on. To change this setting:</p> <ol style="list-style-type: none"> 1. Select the OS/2 System folder from the OS/2 Desktop. 2. Select the System Setup folder. 3. Select the Spooler icon. 4. Select the Print Priority tab from the Spooler Settings dialog box. 5. Print Priority values range from 1 to 189, with a default of 95. Adjust the setting accordingly and close the Settings dialog box. <p>Overcommitment of memory can lead to severe reduction of throughput under OS/2. If there is excessive paging activity (to the SWAPPER.DAT file) or the swap dataset becomes too large, consider increasing the physical memory on the print server. This often can lead to greater performance gains than, for example, use of a faster processor.</p>
------	---

Table E-28. **Components to check for printer performance problems – OS/2** (continued)

Printer	Ensure that the Maximum Transmission Unit size (MTU) is as large as possible. A small MTU size increases the number of packets that are transmitted, allowing greater chances of degradation throughout the network. Increasing the MTU size in both TCP/IP for OS/2 and the IPS printer may improve printer performance.
LAN	If the printer is on a LAN that also has a large number of other devices attached to it, the high levels of traffic on the LAN can cause printer speed degradation. Consider moving the printer to a LAN that does not have so much activity on it.
LAN-to-host attachment	If the speed of the link connecting the LAN with the printer attached to the OS/2 system is slow, this could be a bottleneck. Review your network configuration diagrams to look for any potential bottlenecks.

References – OS/2

The following IBM documents, referenced in this section, can provide additional information on OS/2-to-IPDS printer connectivity.

Table E-29. **Reference documents – OS/2**

Title	IBM order number
<i>PSF/2 – A Guide to Using PSF/2</i>	G544-5225
<i>PSF/2 – Network Configuration Guide for System/370 and Communications Manager/2</i>	S544-3911
<i>PSF/2 – Installation Cookbook for System/370</i>	G544-3965
<i>PSF/2 – Installation Cookbook for AS/400</i>	G544-3966
<i>PSF/2 – “What’s New?”</i>	Online reference included with PSF/2 program materials
<i>TCP/IP for OS/2 – Installation and Maintenance</i>	SC31-6075

Glossary

This glossary contains a list of terms for working with the Xerox DocuPrint 4050/4090 printing systems, and a definition of each.

- A3** Paper size measuring 297 by 420 mm.
- A4** Paper size measuring 210 by 297 mm.
- American Standard Code for Information Interchange (ASCII)** Standard 7-bit code which represents alphanumeric information. Each alphanumeric character and several nonprinting characters are assigned a binary number, covering 128 possible characters. It is used for information interchange among data processing systems, data communication systems, and associated equipment.
- AppleTalk** Network communication protocol inherent to the Apple Macintosh operating system and supported by the DocuPrint NPS.
- application software** Software resident on the host or client workstation used to create print documents.
- B4** Paper size measuring 250 by 353 mm.
- background job** Low-priority job, usually batched, which is executed automatically as system resources become available.
- batch** Method by which bodies of data are accumulated and grouped by kind before processing.
- batch processing** Allows for repetitive operations to be performed sequentially on batched data without much involvement of the computer operator.
- baud** Measurement of data rate in bits per second. This term is used to describe information flow between two devices. Unit of data transmitting/receiving speed is roughly equal to a single bit per second. Common baud rates are 110, 300, 1200, 2400, 4800, and 9600.
- binary** Numbering system based on 2 rather than 10 and containing only the symbols 0 and 1. Binary is especially well suited for use in computers and related devices since information can be represented with electric pulses (0=off, 1=on). Most computer calculations are binary.

binary digit (bit)	<p>In the binary numbering system, either of the characters 0 or 1. The bit is the basic unit of information with which a computer works. It can take the form of a magnetized spot, an electric pulse, a positive or negative charge, etc. A number of bits strung together represents a character to a computer.</p> <p>Multipliers are:</p> <p>1 byte = 8 bits</p> <p>1 kilobyte (KB) or 1,024 bytes = 8,192 bits</p> <p>1 megabyte (MB) or 1,048,576 bytes = 8,388,608 bits.</p> <p>Computer space equivalents are:</p> <p>1.5 KB = about 1 single-spaced typed page</p> <p>30 KB = about 20 typed pages</p> <p>150 KB = about 100 typed pages</p>
bitmap	<p>Electronic definition of an image, comprised of a matrix of picture elements (pixels or dots), where a bit value of one means that the picture element is imaged, and a bit value of zero means that the picture element is not imaged. The number of picture elements in a square area is a function of the display device resolution.</p>
bit mapped	<p>Display image generated bit by bit for each point or dot. A software-driven scanner is used to create characters and/or graphics.</p>
bits per second (bps)	<p>In serial communication, the instantaneous bit speed with which a device or channel transmits a character.</p>
blocking	<p>Process of combining two or more records into a single block of data which can then be moved, operated upon, stored, etc., as a single unit by the computer.</p>
block length	<p>Number of characters or bytes contained in a block of data (the block is treated as a unit within the computer). Block length is usually invariable within a system and may be specified in units such as records, words, computer words, or characters.</p>
boot	<p>To load a program's initial instructions of a program into the computer's memory. These instructions then direct the loading of the rest of the program. Booting may require entry of a few commands at the keyboard or the flip of a switch to begin the process.</p>
break page	<p>See header page</p>
buffer	<p>Compartment of memory in which data is stored during transfer from one device to another. Useful for (1) accumulating data into blocks before storage or processing, and (2) for adjusting differences of speed between devices, or between a device and a communicating facility.</p>
bypass transport	<p>Optional module that moves paper from the printer to a finishing device.</p>

byte	Fixed number of bits (in data processing, usually 8) operated upon as a unit. A byte may represent a character, a machine instruction, or some other logical unit of information.
CCU	Customer changeable unit. In the DocuPrint Models 4850 and 4890, the unit is removed to change the color of the dry ink installed in the printer. Consists of the color developer housing and the dry ink bottle.
CCU changeout cart	Cart used to remove and install the customer changeable unit for changing the color dry ink installed in the printer.
carriage return	Control character that (unless set to be interpreted as a line end) causes the printing system to start printing at the left margin of the current line.
case-sensitive	Treating lowercase and uppercase characters differently.
central processing unit (CPU)	Interprets and executes instructions, performs all operations and calculations, and controls input and output units and auxiliary attachments.
channel	1. In data communications, a path or line that enables two or more devices to communicate (sometimes called a circuit, facility, or link). 2. In computers, a path for communication between the central processing unit (CPU) and input/output units, or between the CPU and peripheral devices.
character	Single printable letter (A-Z), numeral (0-9), symbol (& % #), or punctuation mark (, . ! ?) used to represent data. Characters can also be nonprinting, such as space, tab, or carriage return.
character cell	Digitized space containing a single character within a font set.
character code	Code representing alphanumeric information, for example, ASCII.
character set	Number of different characters used by a particular device, including alphabetic, numeric, and special characters such as symbols.
characters per inch (dpi)	Designates the number of characters per inch for a particular typeface. Refer to pitch.
client software	Software that manages the submission of print jobs to the Printer Controller.
client workstation	Workstation connected to the network used to create print jobs (documents) and submit them to the Printer Controller.
command	Statement entered that instructs the system to perform an operation.

communication line	Telecommunication line connecting devices at one location with devices at other locations in order to transmit and receive information.
communication link	Physical means (i.e., data link) connecting one location to another to transmit and receive information.
compatibility	Characteristic of computer equipment permitting one device to use the same information or programs as another device without conversion or code modification.
compile	To translate instructions written in high-level language into machine language for execution by a system.
concatenate	To connect or link in a series, as when files are grouped together for faster processing. Refer to job concatenation mode.
console	Functional unit containing devices used by an operator to communicate with an IOT. It may consist of a display, keyboard, and certain switches or other controls.
control program	An operating system program that manages job flow, input/output processing, and other overall system functions and resources.
daemon	A task that runs continually in conjunction with the UNIX operating system that periodically checks for specific conditions or logical events and performs some action if the conditions are met. The task can be used to display and notify the operator of such conditions.
database	Information to meet specific processing and retrieval needs. Generally applies to integrated file of data, arranged for access by many subsystems.
data communications	Transmission and reception of encoded information over telecommunication lines.
data file	Collection of related data records organized in a specific manner so that each record is similarly structured, e.g., a payroll file set up with one record for each employee, last name first, indicating the rate of pay and all deductions.
data link	Physical means of connecting one location with another for communication, i.e., the communications lines, modems, and controls which transmit information between two or more stations.
data rate	In data communications, the rate at which a channel carries data, measured in bps (bits per second).
data storage	Preservation of data on various media (e.g., tape, disks, magnetic bubble memory, etc.).

data stream	Format of data passed from one device to another.
data transmission	Transmission of coded data over telephone or other telecommunication lines.
DCIM	Data Control Interface Module. The video interface hardware which resides in the SUN workstation (the DCIM replaces the XEPI board).
decomposer	Printer Controller task that translates print data from the PDL command file into a bitmap image of the page to be printed.
default	Predefined value the system uses when another value is not provided.
device	Any piece of hardware other than the CPU (Central Processing Unit).
DFA	Document Feeding and Finishing Architecture. Software that enables third-party feeding and finishing devices to be attached to a Xerox printer to perform pre- and post-processing functions (such as roll-feeding, saddle-stitching, booklet-making, etc.)
diagnostics	Programs used to diagnose problems within the system or to help service personnel pinpoint the source of such problems.
digitize	To express or represent data in digital (binary) form so that it can be processed electronically.
directory	Logical grouping of files and subdirectories that are identified by name. The directory helps organize data on large storage media.
dithering	The process in laser printing which uses dot patterns to simulate shades of gray or tones of a color.
DOS	Disk Operating System. Operating system commonly used on personal computers. <i>See also</i> operating system.
dot	Unit of measurement representing a fraction of an inch, for example, 300 dots per inch (dpi). May also be referred to as a picture element (pixel) or spot.
dry ink	Minute particles of resin and carbon toner deposited and fused onto the page to create images. Toner is combined with developer to form the dry ink.
duplex	Ability to send and receive information simultaneously.
duplex printing	Printing on both sides (front and back) of a page. <i>See also</i> simplex printing.

electronic publishing	The integrated production of documents on demand, using digitally stored documents, computerized composition, and electronic printing systems.
enabler	Hardware devices or software packages that allow the printer to perform as specified.
Ethernet	Network standard consisting of a coaxial cable or twisted pair and associated components for connecting workstations to each other, to file servers, and to peripherals. This communication system enables workstation users to share information and services.
EtherTalk	Hardware interface and network software for Apple Macintosh computers that provides connection to an Ethernet network.
Extended Binary Coded Decimal Interchange Code (EBCDIC)	Coded character set consisting of 8-bit coded characters. It can accommodate 256 characters.
extension	Portion of a filename that follows a period. In some instances it identifies the file type. For example, .ps specifies a PostScript file.
fault	Condition which prevents proper processing of a print job and requires the intervention of an operator. For example, a paper jam is a fault.
FDL	forms description language. LPS-resident source language used for designing electronic forms. See also FSL; form.
field	Preset place for entering information.
file	Set of records or text that can be stored and retrieved. Organized, named collection of records treated as a unit. For offline, it is the data between the two tape marks. For online, it is the data between banner pages.
file maintenance	Keeping a file up to date by regularly adding, changing, or deleting data.
filename	Name of a file or directory in a command line.
finisher	Any optional output finishing solution, for example, the stitcher/stacker.
firmware	Permanent programs stored in read-only memory (ROM).
fixed disk	Disk drive that is mounted within a computer and is not removable.
fixed font	Font containing characters with fixed spacing.

fixed pitch	Font set in which every character cell has the same width. In reference to character sets, this term describes typefaces in which all character cells are of equal width. Monospaced as opposed to proportional spaced.
fixed spacing	Arrangement of characters on a line so that all characters occupy the same amount of horizontal space.
flag	Small indicator marking the occurrence of an event or the existence of a certain condition while the program is executing.
font	A complete set of alphanumeric characters and punctuation marks, having common characteristics such as style, width, height, and weight.
form	1. Compiled forms source library (.FSL) file. 2. Printed or typed document with blank spaces for inserting information. Specific arrangement of lines, text, and graphics stored in a computer under an identifying name. Page of data that, when preceded by proper commands, is stored on the system disk as a permanent file. It may be merged with variable data by a form start command. See also FDL; FSL.
format	1. Layout of a document, including margins, page length, line spacing, typeface, etc. 2. In data storage, the way the surface of a disk is organized to store data. 3. To prepare the surface of a disk for acceptance of data.
form feed	Keyboard/printer control character that causes the printer to skip the top of the next page.
FSL	forms source library. Uncompiled collection of user-created files containing FDL commands. Refer to FDL; form.
fuse	To affix dry ink to paper by heat or pressure or a combination of both.
HCF	High capacity feeder. An optional feeder module containing two feeder trays that work independently with the standard feeder trays 1 and 2. The HCF increases the feeder capacity by approximately 2,000 sheets and allows automatic tray switching and increased uninterrupted printing time.
hard disk	See fixed disk.
hardware	Physical components (mechanical, magnetic, electronic, etc.) of a system, as opposed to programs, procedures, rules, and associated documentation. The hardware is operated by software and firmware.
header page	Page printed at the beginning of a job that provides information about the print job, such as the name of the document and the job sender.

hexadecimal	Numbering system with a base of 16. In this system, 10 through 15 represented by A through F, respectively.
hierarchy	Relative priority assigned to arithmetic or logical operations that must be performed.
high-level language	Programming language consisting of words and symbols that are close to normal English and, therefore, readily understandable by the user. High-level source languages are used for most commercial programs.
host	Computer accessed by users which serves as a source of high-speed data processing for workstations with less computer power. Commonly referred to as mainframe.
host interface	Connection between network and host computer.
HSB	A printing industry standard color definition model in which all colors are defined in terms of values for hue, saturation, and brightness. Refer to color definition model.
identifier (id)	Characters used to identify or name data and possibly to indicate certain properties of that data.
image area	Area on a physical page that may contain text or graphics.
implementation	Process of installing system hardware and software. Also the process of converting a design into an actual working system.
impressions per minute (ipm)	The number of pages (one side) a printer can print during the space of one minute. Used interchangeably with <i>pages per minute (ppm)</i> .
in-front page	A term that refers to the top page of a double-sided sheet.
initialize	1. To prepare the magnetic surface of a blank diskette so that it can accept data. 2. To set all information in a computer system to its starting values (usually the first step is accomplished when a program is booted).
interface	Hardware that provides physical connection and electronic communication between two hardware devices.
Internet Protocol (IP) address	Refers to an address of any host that uses TCP/IP network protocol.
IOT	Image Output Terminal. See printer.
IPDS	Intelligent Printer Data Stream.
IPS	IPDS Printing System.

JDE	job descriptor entry. Collection of job descriptions. See also job; JSL.
JDL	job descriptor library. Collection of compiled job descriptions. See also JSL.
job	Print data and attributes required for processing and printing a document.
job size	Size of the print master data file measured in bytes.
JSL	job source library. Collection of uncompiled job descriptions. See also job; JDE; and JDL.
label	1. In data storage, a reference to a file saved on tape or disk, a record indicating the file name or date created, and/or other control information. 2. To set all information in a computer system to its starting values (usually the first step is accomplished when a program is booted). 3. In programming, a name assigned to a particular instruction or portion of a program as a locational reference (the computer translates the label into an address).
landscape page orientation	Orientation of print lines or top of an illustration parallel to the long edge of the paper.
language	Defined set of characters and symbols combined together by specific rules. Refer to high-level language and low-level language.
laser printing	Technology that uses a laser to transfer character forms to a page by direct or indirect means.
library	In data storage, a collection of related files or programs.
light emitting diode (LED)	Solid substance that glows when a current is passed through it. Often used for indicator lights on disk drives or modems, as well as for displays on other electronic equipment.
line feed	Control character that (unless set to be interpreted as a line end) causes the printing system to begin printing in the current character position of the next line.
load	To enter data into storage or working registers.
Local Area Network (LAN)	Network connecting computer and peripheral devices through cables.
log	Collection of messages or message segments placed on an auxiliary storage device for accounting or data collection purposes.
logical page	A logical page is defined by an origin location, thus allowing more than one logical page to be placed on a physical page.

long-edge feed (LEF)	The movement of paper through the printer in the direction of the paper length (the longer side of a sheet of paper). <i>See also</i> short-edge feed.
low-level language	Language that is close to machine language so that each written instruction in a program can be converted to machine language on a one-to-one basis.
mainframe	Central processing unit (CPU) and memory of a large computer. More often used to denote any large computer of the type that might be used to control a group of smaller computers, terminals, or other devices. Refer to host.
markform	A parameter name for an end-of-job marker in the IPDS data stream.
megabyte (MB)	A unit of approximately one million bytes.
megahertz (MHz)	1. Unit of cycling speed (one million cycles per second) for an electromagnetic wave (in particular, a radio wave). 2. The sending and receiving stations of a radio wave transmission must be tuned in to the same unit of megahertz.
message	Information passed to the user or to a task within the system. The information is usually associated with an error, fault, or system condition.
MICR	Functionality that produces a Magnetic Ink Character Recognition (MICR) line on negotiable and turnaround documents such as checks and bills. The MICR printing system prints documents using magnetic ink and special fonts to create machine readable information that allows for quick document processing. In general, MICR is used to print accounting and routing information on blank checks and other negotiable documents.
mixed environment	Group of different printing systems at the same location.
modem	Device that converts digital information into an analog signal suitable for sending over analog telecommunication lines. Also converts an analog signal from telecommunication lines into digital information.
module	Cohesive unit within a program. It is consistent in its level and identifiable in terms of loading or with other units.
network	1. System of geographically separate computers, linked to one another over transmission lines. 2. Communication lines connecting a computer to its remote terminals.
node	Station, terminal, or computer that performs some control operation and influences the operation of the network as a whole.
Novell	Commonly used network communications protocol supported by the DocuPrint NPS.

NPS	Network Printing System
object file	Source file converted into machine language (binary code).
offline	Devices not under the active control of a central processing unit. For example, a computer makes output to a magnetic tape. The tape is then used by an offline printing system to produce printed data. Offline operations are much slower than online operations. Refer to online.
offset	To place pages currently being printed in slightly different positions from previous pages.
offset printing	A widely-used method of commercial and corporate printing, where ink is picked up by a metal or paper plate, passed to an offset drum, and then passed to the paper.
online	Devices under the direct control of a central processing unit, e.g., a printing system in interactive communication with a mainframe. Refer to offline.
operating system	Basic host- controlling program that governs the operations of a computer, such as job entry, input/output, and data management. The operating system is always running when the computer is active. Unlike other types of programs, it does not run to an end point and stop.
orientation	1. In reference to image area, orientation describes whether the printed lines are parallel to the long edge of the paper or the short edge of the paper. 2. Choice of printing portrait (vertically) or landscape (horizontally).
page orientation	Direction in which data is printed on a report. Refer to landscape page orientation and portrait page orientation.
parsing	To read or interpret a command; build up a parameter list from information within a command.
PC	Personal computer. Family of computers that most commonly run a version of DOS.
Page Description Language (PDL)	Page description language used to describe the printing of jobs to a laser printing system. PDL describes the input (type, format, characteristics), performs the processing functions (logical processing), and describes the output (type, format, font selection, accounting options) of a print job.
peripheral	Device used with a computer or workstation, usually for input or output. Printers, modems, and the IPS/NPS cartridge tape drives are examples of peripherals.
platform	Combination of hardware and operating system software.

portrait page orientation	Orientation of print lines or the top of an illustration parallel to the short edge of the paper.
PostScript	Page description language developed by Adobe Systems, Incorporated. PostScript describes the input (type, format, characteristics), performs the processing functions (logical processing), and describes the output (type, format, font selection, accounting options) of a print job.
ppm	Pages per minute.
print attribute	Set of attributes available for controlling the processing of a print job. Print attributes include simplex or duplex printing, media selection, collating, stitching, and so on. Print attributes can be sent to the Printer Controller as part of the job, providing automatic job processing.
printer	Component of the DocuPrint Printing System that accepts data from the Printer Controller and prints the document according to the print attributes specified by the user. The printer also provides paper stacking, collating, and optional finishing. "DocuPrint printer" or "printer" refers to the base printer engine (IOT) only, without the Printer Controller and interface.
Printer Controller	Component of the DocuPrint printing system that manages the spooling and processing of print jobs.
Printer Control Language (PCL)	Printer description language defined by Hewlett-Packard Company. PCL describes the input (type, format, characteristics), performs the processing functions (logical processing), and describes the output (type, format, font selection, accounting options) of a print job.
print quality adjustment (PQA)	The process by which the IPS maintains the electrostatic state of the xerographic subsystem to ensure optimal print quality.
protocol	Formal set of conventions governing the format of data and the control of information exchange between two communication devices.
query	Request for data or other information, entered by an operator while the system is processing.
queue	List of documents waiting to be processed.
Random Access Memory (RAM)	Volatile memory used for temporary storage of data and software commands, used by programs for immediate task processing.
raster data	Binary data, usually consisting of dots arranged in scan lines, according to the print order.
rasterization	The creation of a bitmap image of a page for printing.

raster output scanner (ROS)	Raster output scanner. A motor-driven laser scanning system.
Read-Only Memory (ROM)	Solid-state memory for programs. It cannot be rewritten.
read/write head	A small electromagnet that reads, writes, and erases data in the form of magnetic dots on the surface of an external storage medium, such as a magnetic disk.
real time	To process transactions as they are entered into a system. User and system interchange allow transactions to be processed and the results returned to the user.
resolution	The number of dots per unit. An imaging system converts a character from digitized data into a printed image composed of these tiny dots. The greater the number of dots per inch (i.e., higher the resolution), the clearer the image is produced.
sequencing	Method of ordering messages, records within a file, or statements in a program according to rank or time of entry.
sequential	In numeric sequence, usually in ascending order. As applied to a file organization, describes files in which records are written one after another and cannot be randomly accessed. For example, the first 99 records in a sequential file-access file have to be read before the 100th record is accessible.
short-edge feed (SEF)	The movement of paper through the printer in the direction of the paper width (the shorter side of a sheet of paper).
simplex printing	Printing on one side of the page. <i>See also</i> duplex printing.
small computer system interface (SCSI)	An accepted standard for connecting devices to computers.
software	Programs, including operating systems, procedures, utilities, applications programs, etc., written for a system.
software application	<i>See</i> application software.
spooling	Process of releasing data from main memory and storing it temporarily until a peripheral device is ready to accept it, e.g., storing text before sending it to a printer.
string	Connected sequence of alphanumeric characters treated as one unit of data by a program.
SunOS	Operating system developed primarily by Sun Microsystems for use on Sun computers and workstations. SunOS provides inherent support for UNIX and for TCP/IP.

syntax	Rules governing the structure of expressions in a programming language.
syntax error	System response to a mistake in the entry of a command.
sysgen	Abbreviated form of system generation.
system administrator	Person responsible for configuring, operating, and maintaining the DocuPrint system, and also for installing client software on network workstations.
system generation	Process whereby the system is made ready to operate. Typically involves selecting the operative parameters and activating the relevant software.
System Network Architecture (SNA)	Total description of logical structure, formats, and protocols of operation sequences for transmitting an information unit through the communication system. Developed by IBM for distributed processing networks.
TCP/IP	Transmission Control Protocol/Internet Protocol Commonly used network communications protocol supported by the DocuPrint NPS.
telecommunications	The transfer of data via telephone lines.
teleprocessing	Data transfer via telecommunication lines for processing among various remote terminals and the central processing unit (CPU).
throughput	In data processing systems, the amount of data that can be processed, transmitted, printed, etc., in a specified unit of time.
Token Ring	Network topology in which a control packet or token is passed from station to station in sequential order. Stations needing access must wait for the token before transmitting data. In a Token Ring, the next logical station receiving the token is also the next physical station.
transaction processing	Method of data processing in which files are updated and results are generated immediately after data entry.
translation	1. In data communications, the conversion of one code to another on a character-by-character basis. 2. In programming, the function of a language processor which converts a source program from one programming language to another.
transmission speed	In data communications, the rate at which data is passed through communication lines, usually measured in bits per inch (bpi).
two-up	Application that prints two logical pages on one side of a physical page.

ULTRIX	Operating system that runs on DECStations. It consists of a hierarchical system of commands, shells, files, and directories. <i>See also</i> operating system.
UNIX	Operating system for computers, usually working in a network environment. UNIX consists of a hierarchical system of commands, shells, files, and directories. <i>See also</i> operating system.
user interface (UI)	System for gathering input from a user and presenting data to the user.
virtual page	Page area selected by a forms designer for printing.
virtual printers	Alternate names for the printer which allow different sets of default attributes to be applied to submitted jobs. The operator and system administrator define virtual printer names and the associated set of attributes and values.
workstation	Computer able to process data but designed specifically for interaction with a network.
write	To record data in memory or an external storage medium.
write protection	Data protection feature implemented on magnetic media (e.g., floppy disk) to prevent stored data from being modified, written over, or erased.
xerographic mode	There are two xerographic modes: black mode or highlight mode. Black mode allows printing with black dry ink only, while the highlight mode enables highlight color printing.

Numerics

1/4-inch cartridge tape drive, 2-6
10Mb/sec twisted pair standard, 4-7
4 mm cartridge tape drive, 2-3, 5-8
4090 printer, high-capacity feeder, 3-4
50 Hz voltage requirements
 Delta configurations, 6-3
60 Hz voltage requirements, 6-2

A

access requirements, delivery, 6-14 to 6-16
Advanced Customer Training (ACT), B-3
AFIG (Advanced Function Image and Graphics), 1-1
AFP/IPDS environment, 1-1
AFP1 printer definition, D-2
AIX
 parameters, E-25 to E-27
AIX environment
 channel-attaching to an RS/6000, D-5
 configuring InfoPrint Manager, D-5, E-26
 configuring PSF/6000, D-5, E-26
applications, customer responsibility, 4-3
AS/400, parameters, E-18 to E-24
ASCII, 1-4

B

back panel, Sun workstations, 2-3 to 2-4, 2-6 to 2-7
Barr/AFD, 8-2
base components, 1-6 to 2-10
billing meter
 reading, 8-4
 reporting, 8-4
bus and tag
 cabling, 2-10
 channel connection, 1-2
bus cable, 2-10
bypass transport
 option, 1-4

C

cables
 bus, 2-10
 IBM channel, 7-2
 locations, 7-2
 power, 6-2

 tag, 2-10
cartridge tape
 drive, 2-3, 2-6, 5-8
 ordering, A-6
CD-ROM drive, 2-3, 2-5
central processing unit, 2-2, 2-5
channel attachments, D-1 to D-3, D-6
channel-attached
 cables, 7-2
 systems, 2-10
checklist, installation planning, 4-4 to 4-6
Class 1 laser product, iii
clearance space, 6-5, 6-10 to 6-13
components
 base, 1-6 to 2-10
 hardware, 5-8
 printer, 3-1 to 3-3
 printer controller, 2-1 to 2-10
conditioning paper, A-4 to A-5
connectivity
 boards, 2-1
 multiple, 1-2
connectivity boards, 2-4
consumables supplies tables, A-8 to A-11
control console, printer, 3-1 to 3-3
customer responsibilities, 4-2 to 4-3, 8-2

D

danger labels, iii
data cables, 7-1
Data Control Interface Module (DCIM2) card, 2-1, 2-4
DB-25 connector, 2-3
definitions, *see* sample printer definitions
delivery requirements, 6-14 to 6-16
DELTA configurations, 6-3
developer, A-6
diagnostic software, 2-3
diagnostic tools, 1-5
dimensions, printers, 6-6 to 6-9
diskettes, A-6
display monitor, 2-4, 5-8
documentation
 AIX, E-27
 AS/400, E-24
 IBM, C-2
 IBM channel connections, 7-2
 MVS, E-17
 MVS references, E-17

OS/2, E-35
Xerox, C-1
documentation, other, C-1
drives
 cartridge tape, 2-3, 2-6, 5-8
 CD-ROM, 2-3, 2-5
 disk, 2-5
 floppy disk, 2-2
dry ink, toner, A-6
dual feeder, 6-17
Dual Mode, 1-4
dual stacker, 1-4, 3-5, 6-6 to 6-8, 6-17

E

electrical
 specifications, 5-1 to 5-2, 6-1 to 6-3
environmental requirements, 6-4
Ethernet, 2-1, 2-4
 configurations using, 1-2
 connection usage, 1-4
 requirements, 4-7

F

feeder trays, 1-3, 3-4
floor leveling, 6-14
floppy disk drive, 2-2
fonts
 240 dpi, 1-4
 host-resident, converting, 4-2
fuser
 agent, A-6
 shield, A-6

H

hard disk, 2-2
hardware
 components, 5-8
 specifications, 5-8, 6-17 to 6-18
HCF, 3-4 to 3-5, 6-8 to 6-9
HCU, 2-1, 2-10, 5-7, 5-8
heat dissipation, 6-17 to 6-18
Host Channel Unit, *see* HCU
hotlines
 ozone information, iii
 safety, iv
HPPCL5e, 1-4

I

IBM AFP architecture, 1-1
IBM IPDS Group 3 page printer, 1-1
IBM related documents, C-2
IEEE
 802.3, 4-7

IEEE 802.3, 4-7
input trays, 1-3
installation
 planning checklist, 4-4 to 4-6
 preparation, 4-1 to 4-3
 process, 8-1
 Xerox responsibilities, 4-1
IOT (Image Output Terminal), *see* printer
IPDS data streams, 1-4
IPS Console window, 2-9
IPS Main window, 2-9
IPS Print Engine Monitor window, 2-9
IPS screen, 2-9

J

jams, recovering, 1-3
JES2
 FSS statement parameters, E-3 to E-4
 Initialization Dataset commands example, E-4
 printer definitions, D-1
JES3
 configuring, E-4
 FSS statement parameters, E-4 to E-6
 initialization dataset commands example, E-6

K

keyboard, 2-4, 2-7, 5-9

L

labels
 danger, iii
 selecting, A-2
laser safety, iii
leveling, floor, 6-14
license, software, 8-3

M

maintenance
 ongoing, 8-4
 routine, 8-4
meter, billing
 reading, 8-4
 reporting, 8-4
monitor, 2-4, 5-8
mouse, 2-4, 2-8, 5-9
MVS
 channel attachment, D-1 to D-3
 TCP/IP connection, E-1 to E-17

N

network
 interface requirements, 4-7

network configurations

- AIX, E-26
- AS/400, E-18
- MVS, E-1
- OS/2, E-28

network interface requirements, 4-7

O

operating systems supported, 1-1

operation safety, iii

ordering supplies, A-12 to A-13

OS/2

- examples, D-4 to D-5
- parameters, E-28 to E-35

OS/390, *see* MVS

outlets, power configurations, 5-2, 6-2

Output Configuration window, 3-5

ozone, iii

P

pad, 2-8

paper

- advanced handling, 1-3
- characteristics, A-2
- conditioning, A-4 to A-5
- jams, recovering, 1-3
- recommended weight, grade, A-1
- size, 3-5, A-1 to A-2
- storing, A-3

perforated paper, A-2

personnel, training, 4-3

planning checklist, 4-4 to 4-6

PostScript level 2, 1-4

power

- cord, 6-2
- requirements, 5-1 to 5-2, 6-1 to 6-3, 6-17 to 6-18

predrilled paper, A-2

preprinted paper, A-2

printer

attention

- alarm, 3-1
- light, 3-1

components, 3-1 to 3-3

configurations, 3-4 to 3-6

control console, 3-1 to 3-3

defining, 8-3

dimensions

- dual stacker, 6-6
- HCF, 6-8
- HCF and stitcher/stacker, 6-9
- stitcher/stacker, 6-7

installation, 8-1

maintenance, 8-4

performance

- AS/400, E-24

MVS, E-16

OS/2, E-34 to E-35

pinging

- AS/400, E-22 to E-24
- MVS, E-14 to E-15
- OS/2, E-32 to E-33

power requirements, 6-17 to 6-18

Printer control console, 3-1

Purge tray, 3-1

queues

- PSF/2, defining, E-31 to E-32

sample definitions

- MVS with channel attachment, D-1 to D-3
- MVS with TCP/IP connection, E-1 to E-17
- OS/2 with channel attachment, D-4 to D-5
- VM with channel attachment, D-6
- VSE with channel attachment, D-6

Sample tray, 3-1

printer controller

- components, 2-1 to 2-10
- placement, 5-3 to 5-7
- space requirements, 5-3 to 5-7

printing test jobs

- OS/2, E-33

processor, 2-2, 2-5, 5-8

production speeds, 1-2

program temporary fixes, *see* PTFs

PSF

- eligible platform, 1-1
- handshaking, 2-10

PSF printer definitions, D-1

PSF/2, defining printer, E-30 to E-31

PSF/MVS

- configuring, E-7
- PRINTDEV statement example, E-11
- PRINTDEV statement parameters, E-7 to E-10

PSF/VSE, 1-1

PTFs, E-25

publications, related, C-1

publications, related, *see* documentation**R**

requirements

see also specifications

- clearance space, 6-10 to 6-13
 - delivery access, 6-14 to 6-16
 - environmental, 6-4
 - Ethernet, 4-7
 - network interface, 4-7
 - power, 5-1 to 5-2, 6-1 to 6-3, 6-17 to 6-18
 - printer controller space, 5-3 to 5-7
 - space, 5-3, 6-10 to 6-16
 - Token Ring, 4-7
- resolution, 300 dpi, 1-3
- responsibilities
- customer, 4-2 to 4-3

installation
 customer, 8-2
 Xerox, 8-2
 Xerox, 4-1 to 4-2
 RISC-based controller, 1-1

S

S/370 bus, 2-10
 safety
 hotline, iv
 precautions, iii
 standards, iii
 sample printer definitions
 MVS with channel attachment, D-1 to D-3
 MVS with TCP/IP connection, E-1 to E-17
 OS/2 with channel attachment, D-4 to D-5
 VM with channel attachment, D-6
 VSE with channel attachment, D-6
 SCSI cartridge tape drive, 2-3, 2-6
 selecting
 labels, A-2
 paper, characteristics, A-2
 transparencies, A-2
 serial ports, 2-3
 service
 telephone number, B-1
 Xerox responsibilities, 4-2
 shared space, 6-10 to 6-13
 site
 personnel, customer responsibility, 4-2
 preparation, customer responsibility, 4-2
 selection, Xerox responsibilities, 4-1
 Sixth Sense, 1-5
 Sixth Sense Remote Service, B-2
 Software license, 8-3
 software licensing, 8-3
 software prerequisites
 AIX, E-25
 AS/400, E-18
 MVS, E-1
 OS/2, E-28
 space
 planning guidelines, 6-10
 requirements, 5-3, 6-10 to 6-16
 specifications
see also requirements
 electrical, 5-1 to 5-2, 5-8, 6-1 to 6-3, 6-17 to 6-18
 printer, 6-17 to 6-18
 stitcher/stacker, 1-4, 3-6, 6-7 to 6-9, 6-18
 Sun workstations, 1-1, 2-1 to 2-4, 2-4 to 2-8, 5-4, 5-5
 supplies
 cartridge tapes, A-6
 checklist, A-14
 consumables tables, A-8 to A-11
 developer, A-6
 diskettes, A-6

dry ink, toner, A-6
 fuser
 agent, A-6
 shield, A-6
 paper, A-1 to A-3
 supplies table, A-8 to A-11
 support services, A-12 to A-13
 system controller, *see* Printer Controller

T

tag cable, 2-10
 tape drive, 2-3, 2-6, 5-8
 TCP/IP
 defining, E-1 to E-35
 Ethernet interface, 1-2
 MVS
 configuring, E-11
 Profile dataset, E-12 to E-13
 telephone numbers
 service, B-1
 Xerox Parts and Product Support Center, A-12
 Xerox Product Safety, iv
 Xerox Supply Center, A-12
 three-phase
 DELTA, 6-3
 tinted paper, A-2
 Token Ring, 1-2, 2-1, 2-4, 4-7
 connection usage, 1-4
 toner, *see* dry ink
 training, 8-1
 Customer responsibility, 4-3
 operators, B-3
 Xerox responsibilities, 4-2
 transmission rate, 1-2
 transparencies, selecting, A-2
 trays
 capacities
 dual stacker, 1-4, 3-5
 HCF, 3-4
 stitcher/stacker, 1-4, 3-6
 feeder, 1-3
 input, 1-3
 types, 3-1
 turning radius, 6-14 to 6-16

U

Ultra 2 workstation, *see* Sun workstations
 UltraSPARC workstation, *see* Sun workstations
 United States/Canada, 5-2

V

vertical clearance, 6-5
 VM, D-6
 voltages, requirements, 5-2

VSE, D-6

W

When, 8-3

work area, setting up, 2-1 to 6-18

workstations *see* Sun workstations

X

Xerox Customer Documentation Catalog, B-3

Xerox Customer Education, B-4

Xerox Customer Parts and Product Support Center,
A-12

Xerox Customer Service Support Center, B-1

Xerox Documentation and Software Services
(XDSS), B-3

Xerox Font Center, B-4

Xerox Printing Systems Customer Support Center,
B-2

Xerox Product Safety, iv

Xerox related documents, C-1

Xerox responsibilities, 4-1 to 4-2, 8-2

Xerox Supply Center, A-12

