

User Guide

XEROX



XEROX
THE DOCUMENT COMPANY

P.O. Box 9604-7994
Webster, N.Y. 14580-7994

2/2000
701P33223

WorkCentre Pro 215

ENERGY STAR



As an ENERGY STAR® Partner, Xerox Corporation has determined that this product meets the ENERGY STAR® guidelines for energy efficiency.

© 2/2000 by Xerox Corporation. All rights reserved.

Copyright protection claimed includes all forms and matters of copyrighted material and information now allowed by statutory or judicial law or hereinafter granted, including without limitation material generated from the software programs that are displayed on the screen such as icons, screen display looks, etc.

XEROX®, The Document Company®, the stylized X and WorkCentre Pro 215 are registered trademarks of Xerox Corporation and Xerox Canada Ltd. is a licensee of all the trademarks.

Product names used in this guide may be trademarks or registered trademarks of their respective companies and hereby acknowledged.

ENERGY STAR is a U.S. registered mark.

Customer Support

Congratulations on acquiring your Xerox WorkCentre Pro 215. The Xerox Welcome Center is available to you if you need assistance.

Fill in the required information below so it is available when calling for service.

- Customer Account Number: _____
- Machine Type: WorkCentre Pro 215
- Machine serial number: UU4 and the _____.
(Product Code) (Serial number)

The serial number is located on the back cover of the Pro 215, to the left of the power cord.

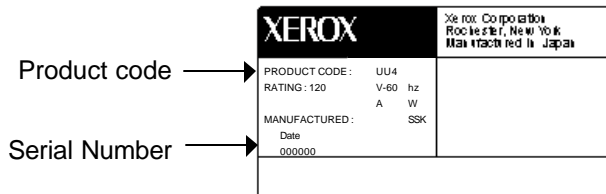

Use the appropriate number, shown below, to call our experts.

Xerox Welcome Center

If you experience difficulty operating your WorkCentre Pro 215, refer to the suggestions in the Problem Solving section of this user guide to quickly resolve the situation yourself. If the difficulty persists, contact the Xerox Welcome Center for further assistance.

When you call the Center, please have the serial number that you entered at the top of this page readily available. Also, record any Status Code information that appears in the Message Display on the Control panel. This information can help you and the Xerox representative solve the problem.

Xerox Welcome Center Telephone Numbers

Call: USA (English): 1-800-821-2797

Canada: 1-800-939-3769

(Spanish): 1-800-821-7726

In Canada, after choosing a language option, select option #2 for digital machines.

Internet Support

Visit our website at www.xerox.com to download the latest print driver software or to view on-line product documentation information.

Supplies

For customers on the **supplies included plan** (also know as the metered plan or the cost per copy plan), please use the following:

Toner Cartridge: 6R987

Drum Cartridge: 13R573

In the U.S.A. call 1-800-599-2198

In Canada call 1-800-668-0199 (English)

1-800-668-0133 (French)

For customers who purchase supplies **directly from Xerox Corporation**, please order the following:

Toner Cartridge: 6R988

Drum Cartridge: 13R573

In the U.S.A. call 1-800-822-2200

In Canada call 1-800-668-0199 (English)

1-800-668-0133 (French)

Or purchase supplies on line at www.xerox.com

It's Illegal

In the USA

It is against US law to copy copyrighted material without permission of the copyright owner unless the copying falls within the "Fair Use" or library reproduction rights of the copyright law. Further information on these U.S. provisions may be obtained from the Copyright Office, Library of Congress, Washington, D.C. 20550, or telephone the Copyright Office at (202) 707-9100 and ask for circular 21. Copying of other items may be prohibited. If you have any questions, seek legal advice.

In Canada

In Canada it is against the law to copy copyrighted material without permission of the copyright owner, unless the copying falls within the private study, research or criticism provision of the copyright law. Copying of other items may be prohibited. If you have any questions, seek legal advice.

FCC Compliance in the USA

WARNING: This equipment has been tested and found to comply with the limits for a Class B digital device, pursuant to Part 15 of the FCC Rules. These limits are designed to provide reasonable protection against harmful interference in a residential installation. This equipment generates, uses and can radiate radio frequency energy and, if not installed and used in accordance with the instructions, may cause harmful interference to radio communications. However, there is no guarantee that interference will not occur in a particular installation. If this equipment does cause harmful interference to radio or television reception, which can be determined by turning the equipment off and on, the user is encouraged to try to correct the interference by one or more of the following measures:

- Reorient or relocate the receiving antenna.
- Increase the separation between the equipment and receiver.
- Connect the equipment into an outlet on a circuit different from that to which the receiver is connected.
- Consult the dealer or an experienced radio/TV technician for help.

Changes or modifications to this equipment not specifically approved by the Xerox Corporation may void the authority granted by the FCC to operate this equipment.

Shielded cables must be used with this equipment to maintain compliance with FCC regulations

Installed Printer Board

Declaration of conformity

This device complies with Part 15 of the FCC Rules. Operation is subject to the following two conditions: (1) This device may not cause harmful interference, and (2) this device must accept any interference received, including interference that may cause undesired operation.

Model Number: AR-PB9 (pre-installed)

Contact: Xerox Corporation

Phone: (716) 422-412

Address: 800 Phillips Road
Webster, New York 14580
USA

Xerox







AR-PB9



Tested to comply with
FCC Standards

FOR HOME OR OFFICE USE

Table of Contents

| | |
|---|----|
| Safety Notes..... | 1 |
| Helpful Hints..... | 4 |
| Getting to Know Your Pro 215..... | 5 |
| Installation..... | 6 |
| Control Panel..... | 10 |
| Power Reduction / Auto Clear..... | 12 |
| Auto Copy Function..... | 12 |
| Paper Specifications..... | 13 |
|  Loading Paper..... | 14 |
| Flashing  | 15 |
| Making Copies on the Document Glass..... | 16 |
| Making Copies on the Automatic Document Feeder..... | 17 |
| Manual Two-Sided Copying..... | 20 |
| Image Quality..... | 21 |
| Reduction/Enlargement..... | 22 |
| Alternate Paper Tray..... | 23 |
| Envelopes..... | 24 |
| Customizing Your Pro 215..... | 25 |
| Programmable Features..... | 25 |
| Programmable Feature Settings 0 – 9 and 11 – 21..... | 28 |
| Programmable Feature Setting 10..... | 29 |
| Pro 215 Care..... | 30 |
| Cleaning the Document Glass and Cover..... | 30 |
| Cleaning the Corotron Wire..... | 30 |
|  Automatic Document Feeder Misfeed..... | 31 |
|  – E2 Clearing the Paper Path..... | 32 |
|  Toner Cartridge Replacement..... | 35 |
|  Toner Cartridge Yield..... | 36 |
|  J2 Drum Cartridge Replacement..... | 37 |
| Counter access..... | 38 |
| Total copies/prints remaining on the drum cartridge..... | 38 |
| Printer Driver Software Installation..... | 39 |
| Ethernet Network Interface (optional)..... | 41 |
| Upgrade Memory..... | 42 |

Safety Notes

Your Pro 215 and supplies have been designed and tested to meet strict safety requirements. These include safety agency examination and approval, and compliance to established environmental standards. Please read the following instructions carefully before operating the Pro 215 and refer to them as needed to ensure the continued safe operation of your Pro 215.

Follow all warnings and instructions marked on or supplied with the product.

Symbology:  = High Voltage,  = Heated Surface,  = Warning

 = **Laser Caution** use of controls or adjustments or performance of procedures other than those specified herein may result in hazardous radiation exposure.

Unplug this Pro 215 from the wall outlet before cleaning. Always use materials specifically designated for this Pro 215. Use of other materials may result in poor performance and could create a hazardous situation.

Do not use aerosol cleaners. Follow the instructions in this User Guide for proper cleaning methods.

Never use supplies or cleaning materials for purposes other than what they were intended. Keep all supplies and materials out of reach of children.

Do not use this Pro 215 near water, wet locations, or outdoors.

Do not place this Pro 215 on an unstable cart, stand, or table. The Pro 215 may fall, causing personal injury or serious damage to the Pro 215.

This product is equipped with a 3-wire grounding type plug (e.g., a plug having a third grounding pin). This plug will fit only into a grounding-type power outlet. This is a safety feature. To avoid risk of electric shock, contact your electrician to replace the receptacle if you are unable to insert the plug into the outlet. Never use a grounding adapter plug to connect the Pro 215 to a power source receptacle that lacks a ground connection terminal.

Safety Notes

This Pro 215 should be operated from the type of power source indicated on the marking label. If you are not sure of the type of power available, consult your local power company.

Do not allow anything to rest on the power cord. Do not locate the Pro 215 where persons will step on the cord.

The power supply cord is the disconnect device for this equipment. Insure that installation is near the outlet and is easily accessible.

Your machine is equipped with an energy saving device to conserve power when the machine is not in use. The machine may be left on continuously.

Slots and Openings in the cabinet and in the back and sides of the Pro 215 are provided for ventilation. To ensure reliable operation of the Pro 215 and to protect it from overheating, these openings must not be blocked or covered. The Pro 215 should never be located near or over a radiator or heat register. This Pro 215 should not be placed in a built-in installation unless proper ventilation is provided.

Never push objects of any kind into the slots of the Pro 215 as they may touch dangerous voltage points or short out parts which could result in a fire or electric shock.

Never spill liquid of any kind on the Pro 215.

Never remove covers or guards that require a tool for removal. There are no casual operator serviceable areas within these covers.

Never defeat interlock switches. Machines are designed to restrict operator access to unsafe areas. Covers, guards, and interlock switches are provided to ensure that the machine will not operate with covers opened.

Use of an extension cord with this Pro 215 is not recommended or authorized.

Avoid direct viewing of the document lights. The lamps are bright and, while not harmful, they may cause an annoying afterimage. Always keep the document cover closed during operation and storage.

Avoid exposing the drum cartridge to light for extended periods of time.

Safety Notes

Do not touch the green photoreceptor. Scratches or smudges that appear on the photoreceptor will result in poor copy quality and may shorten the service life.

Do not put your hands into the fuser area, as you may be burned.

Ozone: This product produces ozone during normal operation. The ozone produced is dependent on copy volume and is heavier than air. Providing the correct environmental parameter, as specified in the Xerox installation procedures, ensures that concentration levels meet safe limits.

If you need additional safety information concerning the Pro 215 or Xerox supplied materials, you may call the following toll-free number.

In the United States or Canada: **1 – 800 – 828 – 6571**

Helpful Hints

Care of your WorkCentre Pro 215

- Do not place heavy objects on any surface of the WorkCentre Pro 215.
- Take care not to place liquids on or near the WorkCentre Pro 215.
- Avoid placing clips or staples on any WorkCentre Pro 215 surface.

Maintenance

- Clean the Document Glass daily and as required.
- Do not apply cleaning liquids or sprays directly to the WorkCentre Pro 215; apply to the cloth first.
- Store paper in a dry area, on a flat surface, and in a closed cabinet.
- Wrap partially-used reams of paper tightly.

WorkCentre Pro 215 location

For reliable WorkCentre Pro 215 operation and copy quality, Xerox recommends:

- Place your WorkCentre Pro 215 in a well-ventilated room.
- Recommended environment:
 - Temperature: 50° to 90°F / 10° to 32°C.
 - Humidity: 20% to 85%.
- Place the WorkCentre Pro 215 on a flat, level surface.
- Avoid locations that subject the WorkCentre Pro 215 to:
 - Direct sunlight.
 - Extreme changes in temperature or humidity.

Getting to Know Your Pro 215

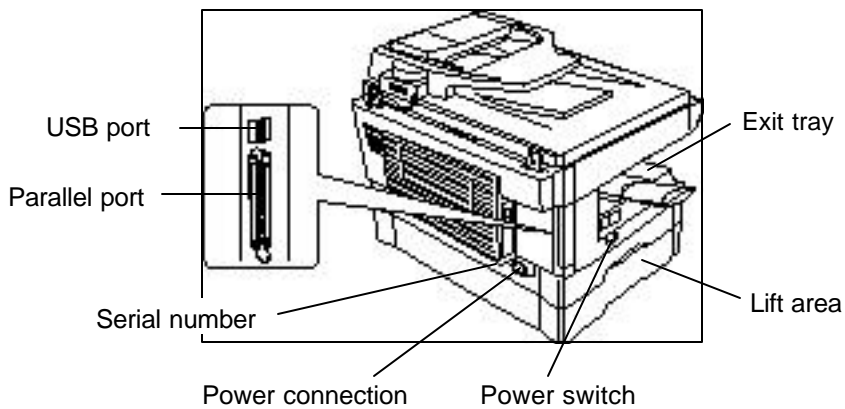
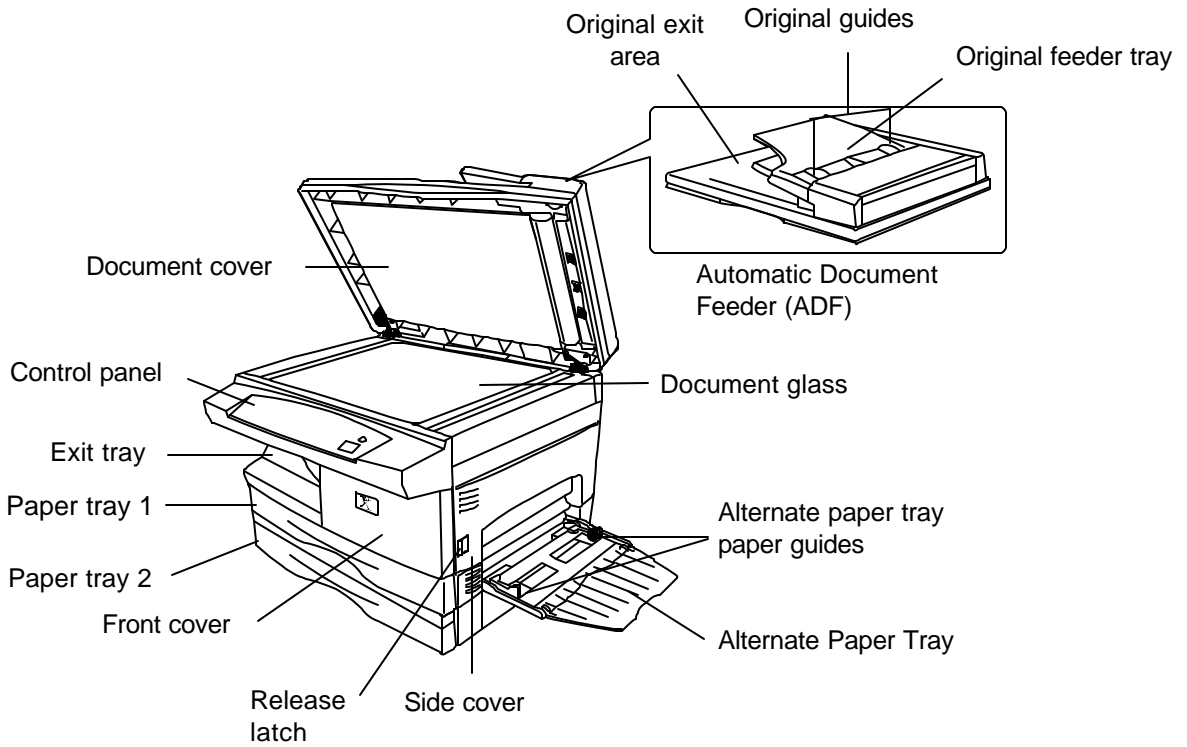

Installation

As you unpack the Pro 215, familiarize yourself with its contents. After the Pro 215 is installed, and the Ready Indicator is lit, the Pro 215 is ready to make copies.

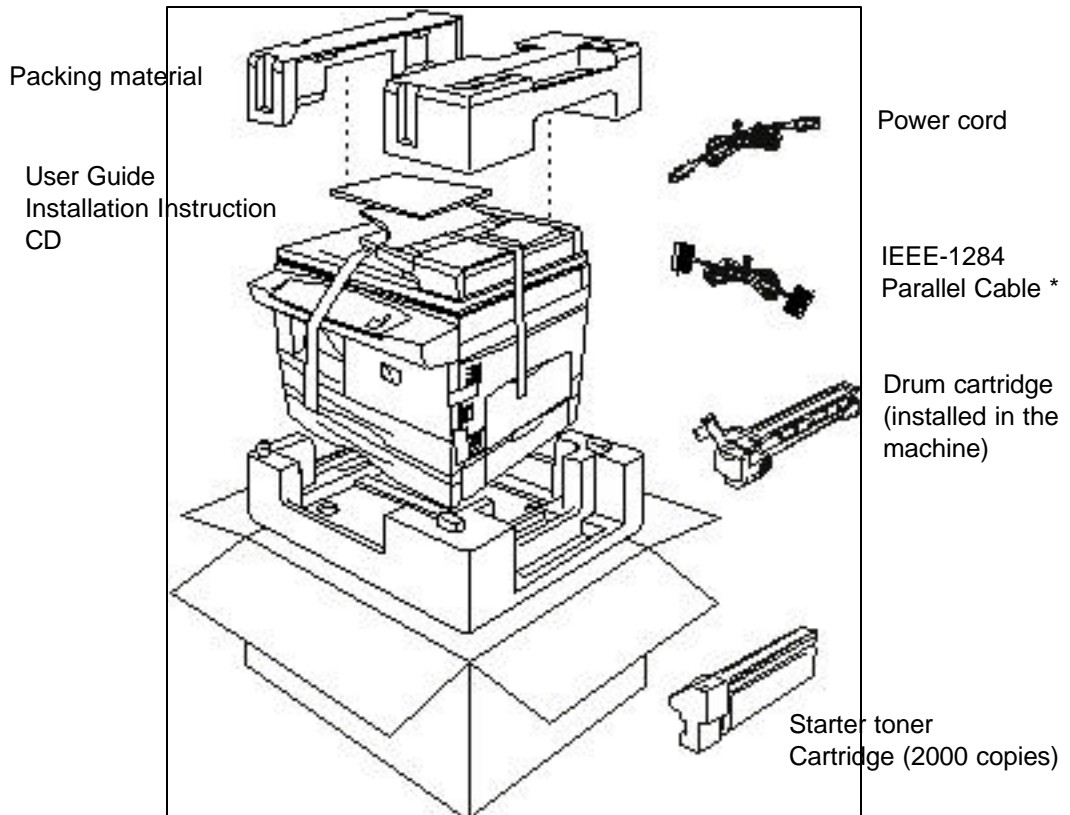

*** Note:** To ensure reliability of the Pro 215 use the IEEE-1284 compliant parallel cable that is supplied with the machine. Only cables labeled "IEEE-1284" can be used with your Pro 215.

Installation *(continued)*

Follow the steps below to properly set up your Xerox Pro 215.

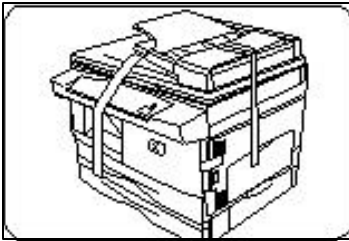

1. Remove the bag from the Pro 215.
2. Remove the pieces of tape and the packing material.

Remove the tape and the packing material supporting the clear plastic 2-sided tray.



3. To ensure the 2-sided tray is in the correct position, gently push it in the direction shown by the arrow.

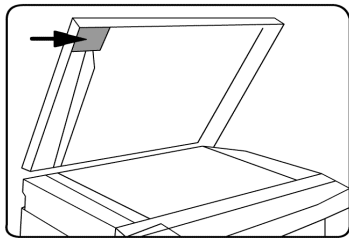

4. Open the Automatic Document Feeder (ADF) and remove the packing materials shown.

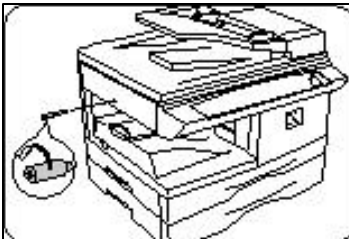

5. Unscrew and remove the shipping screw from the left side of the Pro 215.

CAUTION: The Pro 215 will malfunction if the shipping screw is not removed.

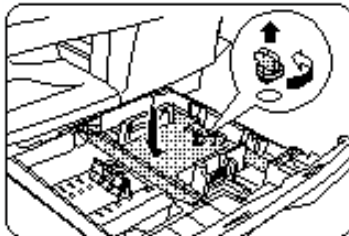

6. Lift and pull open the paper tray. Turn and remove the paper tray button.

CAUTION: Paper will misfeed if the paper tray button is not removed.

Note: Be sure to remove the pressure plate lock from both paper trays.

Installation *(continued)*

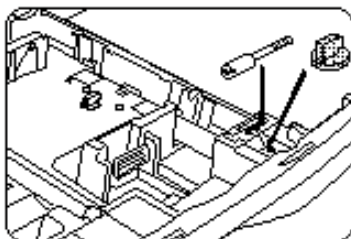

7. Secure the paper tray button and the shipping screw in the locations shown.
 - Turn the paper tray button to secure its storage position.

Note: Save the paper tray button and the shipping screw. They will be needed if the Pro 215 has to be moved.

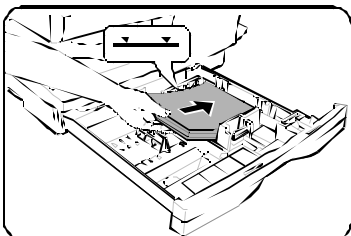

8. Load paper into the tray.
 - Refer to the **Loading Paper** section for additional information.
 - Do not fill above the max line.
9. Push the paper tray firmly back into the Pro 215.

Note: Ensure that the alternate paper tray is lowered.

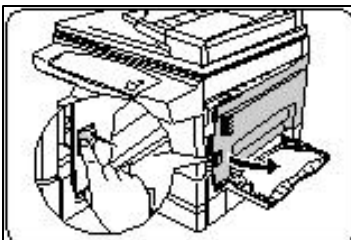

10. Press the release lever to open the side cover.

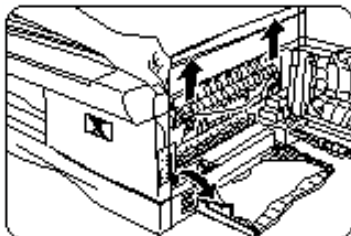

11. Remove the Caution tape from the cover.
12. Remove the two red fuser pins by pulling the string upward one at a time.
 - Discard the fuser pins.

Note: Misfeeds will occur if the fuser pins are not removed.

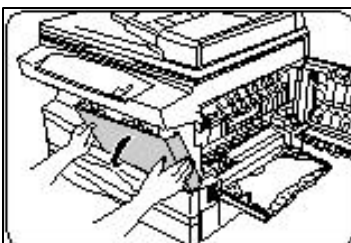

CAUTION: Ensure that the side cover is always open before opening the front cover.

13. Press the front cover release buttons to open the front cover.

Installation *(continued)*

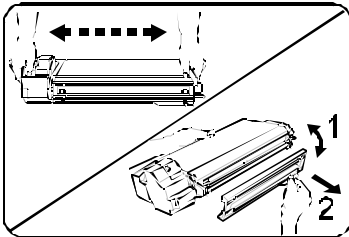

14. Remove the starter toner cartridge from the silver bag. Vigorously shake the cartridge to loosen the toner.
 - Thoroughly shaking the cartridge will assure maximum copies per cartridge.
 - Xerox has included a Starter Toner Cartridge. This cartridge will last approximately 2000 copies. Purchased replacement toner cartridges will yield approximately 7500 copies.

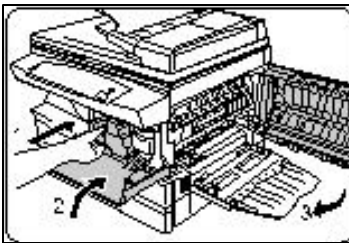

15. Remove the toner cartridge cover.
16. Slide the toner cartridge into the Pro 215 until it locks into place.
17. Close the front cover and the side cover.

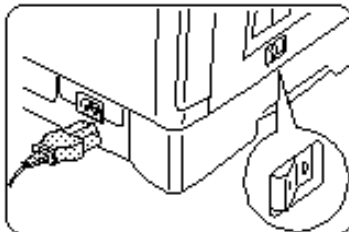

Skip to the Printer Driver Software Installation section in this User Guide to set up the Pro 215 for printing.

18. Plug the power cord into the Pro 215 and then into a grounded outlet.
19. Turn on the power switch. In approximately two seconds the ready indicator will light. The machine is now ready to copy.

Control Panel

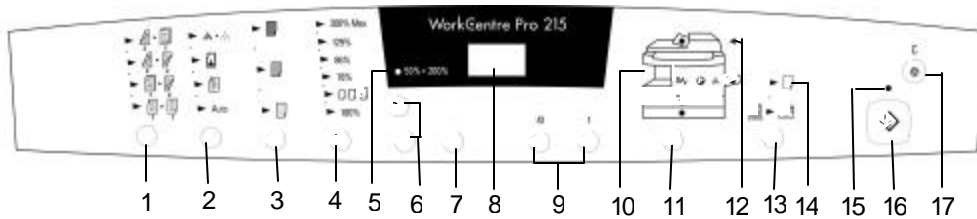

The control panel has keys and lights that are used to control and display the conditions of the Pro 215.

- 1-Sided/2-Sided Mode:** Use the 2-Sided copy feature to make one or two-sided copies from one or two-sided originals. Refer to the **Making Copies on the Automatic Document Feeder** section for detailed information.
- Image Quality Mode:** The image quality mode is used to maximize copy quality.
Auto – for originals with a colored background or mixed text and graphics.
Text – for originals that contain mainly text.
Photo – for copying photographs.
Toner Save – decreases the overall copy density in order to extend the life of the toner cartridge.
- Copy Contrast:** Press the contrast keys to lighten or darken copies while in the Text, Photo, or Toner Save settings. Refer to the **Image Quality** section for detailed information.
- Preset Reduction/Enlargement:** Press this key to select any of the preset reductions or enlargements.
 - The (customer settable) percentage has been set at the factory for 50%. Refer to **Customizing Your Pro 215** for information about changing this percentage.
- Percentage Indicator:** The indicator will light when any reduction or enlargement setting is selected.
- Variable Percentage:** Press the **down** key to **decrease** the percentage. Press the **up** key to **increase** the percentage. Any percentage from 50% to 200% may be selected.
- %:** Press this key to display the reduction/enlargement percentage selected.
- Display Window:** Copy quantity, reduction/enlargement settings, and status codes appear in this area.
- Quantity Keys:** Select up to 100 copies. Press the **1** key to increase the quantity by one. Press the **10** key to increase the quantity by 10.
 - To display the number of copies requested during the copy run press the 10 key.
 - Press the Clear key to clear the selected quantity.

Control Panel

- 10. Pro 215 Diagram:** Helps you locate areas that require your attention. The indicators will flash in the area requiring attention. For additional information refer to the **Problem Solving** section.
- 11. Paper Supply Selection:** Press to change the selected paper supply. The selected paper supply location will be indicated by a green light on the Pro 215 diagram.
- 12. ADF Misfeed Indicator:** This indicator will light when a misfeed occurs in the ADF.
- 13. On-line/Off-line Key:** Press this button to alternate between On-line and Off-line status. When the light is lit, the printer is On-line.
- 14. Data LED:** This LED indicates the processing of electronic data in the Pro 215 PCL Controller. The LED is ON when the Pro 215 is printing documents. The LED is OFF when no data is present. The LED is blinking when the Pro 215 is receiving data sent to the printer.
- 15. Ready Indicator:** When the light is ON (not flashing), the Pro 215 is ready to make copies. When the light is flashing after the Start key is pressed, the Pro 215 is warming up and the copy cycle will begin automatically.
- 16. Start:** Press this key to begin copying.
 - The display will change to 1 and increases by 1 as each copy is made.
- 17. Clear/Stop:** Press this key to stop the Pro 215 while making copies or to clear copy quantity. If the key is pressed twice quickly, all programming will be cleared.

Power Reduction / Auto Clear

Power Reduction Modes automatically reduce power consumed by the Pro 215 when the Pro 215 has not been used for a set period of time. There are two modes of power reduction; **Power Save**, and **Power Shut-off**.

Power Save Mode – The Ready Indicator will flash and the other indicators will remain on. To copy from the Power Save mode select the desired features and press Start. The copies will be made automatically.

Power Shut-Off Mode – When the Pro 215 enters the power shut-off mode the Ready Indicator will flash and the other indicators will turn off. To copy from the power shut-off mode, press the Start button, then, select the desired features and press Start again. The copies will be made automatically.

Auto Clear – This Pro 215 is enabled at the factory to return to the Normal Copy Mode approximately one minute after a job is completed. Unless otherwise programmed, the Normal copy Mode settings are as follows:

- Copy Quality – Auto
- Copy Lighter/Darker – Normal
- Priority Tray – Tray 1
- Priority Magnification – 100%
- Quantity Selected – 1

Note: Time periods for the Power Shut-Off, Power Save, and Auto Clear modes can be modified to meet your specific copying needs. Refer to **Customizing Your Pro 215** section of this User Guide for information about changing these settings.

Auto Copy Function

This function provides the ability to program a copy job while the copier is warming up, or to pause a print job to enable copying.

1. Program the copy job.
2. Press Start.
 - The current page will be completed if printing is in process.
3. When the copy job is completed, press the On-line/Off-line button to immediately return to the print job.

Paper Specifications

Paper Storage

Note: Paper affected by humidity, and curled paper can cause jams and copy quality problems.

For reliable copier operation and good copy quality, Xerox recommends that paper be stored:

- on a flat surface.
- in a closed container.
- in a low humidity area.
- tightly wrapped, if the ream is partially used.

The Specifications Chart below provides information about the types of paper that can be used at each of the paper input areas.

| Paper Input | Paper Tray 1 and 2 | Alternate Paper Tray |
|---|---------------------------------------|---------------------------------------|
| Paper Sizes | 5.5×8.5" to 8.5×14" / A5 to 216×356mm | 3.5×5.5" to 8.5×14" / A6 to 216×356mm |
| Paper Weights | | |
| Optimum | 20 lb / 80 gsm | 20 lb / 80 gsm |
| Range | 15 – 24 lb / 56 – 90 gsm | 14 – 34 lb / 52 – 130 gsm |
| Paper Capacities | | |
| Copy, letterhead, and predrilled | 20 lb / 80 gsm 2×250 sheets | 20 lb / 80 gsm 50 sheets |
| Labels, Envelopes, and Transparencies * | No | Yes (1 at a time) |

* Use labels, envelopes, and transparencies specifically designed for copiers and laser printers (high temperatures).

Loading Paper

 will flash in the copy quantity display and the green indicator in the copier diagram will flash when:

- a paper tray is empty.
- paper misfeeds: paper has **not** fed all the way into the copier.
- a paper tray is not closed properly.

If the paper has misfed, open the paper tray indicated by the flashing green light on the copier diagram and remove the misfed paper.

- Do not reuse the misfed paper.
- Ensure that the paper is under the corner snubbers.
- Close the paper tray.
- If copying, press the Start key to make the remaining copies.
- If printing, the job will automatically resume when paper is added.

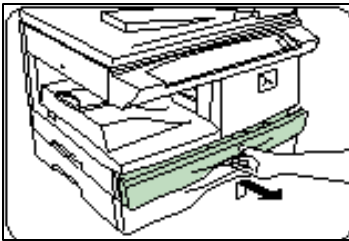

1. Lift and pull open the paper tray.

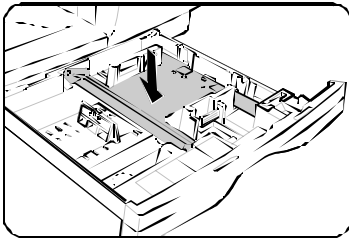

2. Push down on the pressure plate until it locks in position.

Note: The procedures for loading paper into tray 1 and tray 2 are identical.

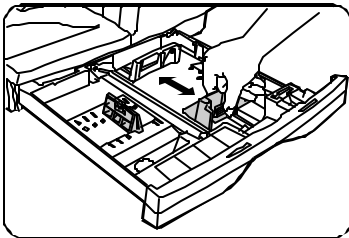

3. Adjust the paper guides to the desired paper size.

- Squeeze the side guide.
- Lift and insert the rear guide.
- When adding paper larger than 8.5×11/A4, remove the rear guide and store it in the pocket in front of the side guide.

P Loading Paper

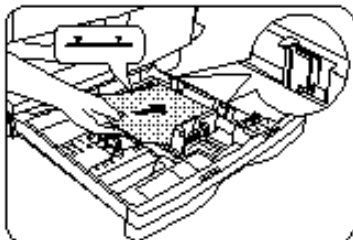

4. Fan the paper and insert it into the tray.
 - Ensure that the paper corners are under the corner snubbers.
 - Do not fill above the max fill line.
5. Close the paper tray.
6. If copying, press Start to continue. If printing, the job will automatically resume.
 - To cancel the flashing **P** without restarting copying, press the Clear button.

Flashing P

When the Alternate Paper Tray runs out of paper, or the paper misfeeds, the **P** will flash in the display and the green indicator in the copier diagram will flash.

Alternate Paper Tray

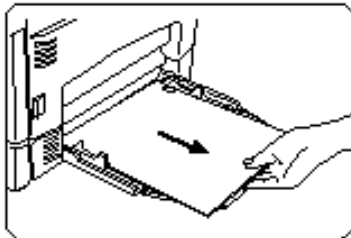
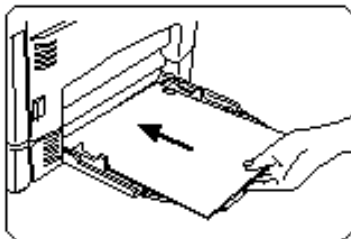

1. Add paper if the Alternate Paper Tray is empty.
2. If paper has misfed, remove it by carefully pulling the edge of the paper in the direction of the arrow.
3. If copying, press the Start key to continue.
If printing, press the On-line/Off-line key to continue.

Making Copies on the Document Glass

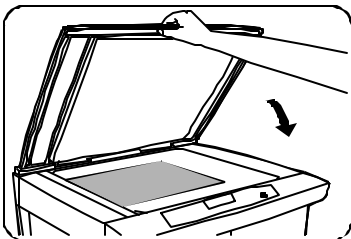
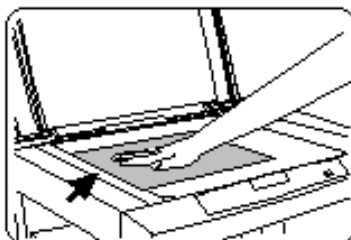
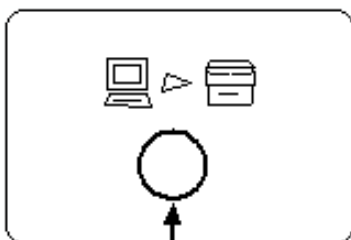

1. Ensure that the Pro 215 is Off-line.
 - The light between the two icons will be **off**.
 2. Select the desired copy features from the control panel.
 3. Select the number of copies.
 - Press the **10** to increase the quantity by 10. Press the **1** key to increase the quantity by 1.
 - To clear the selected quantity, press the Clear key.
 4. Lift the Document Cover.
 5. Place the original **face down** and align it with the registration guide on the document glass.
 6. Close the Document Cover.
- Note:** Leaving the cover open while copying will affect copy quality and toner consumption.
7. Press Start to begin copying.
 - The number in the display window returns to 1 and advances as each copy is made.

Making Copies on the Automatic Document Feeder

The Automatic Document Feeder (ADF) allows you to automatically make single-sided or two-sided copies. The ADF holds up to 30 originals (20 lb/80 gsm). Ensure originals are in good condition, and that all staples and paper clips have been removed. Use the document glass to make copies from transparencies, facsimile paper, or originals having other unusual characteristics. For reliable copying operation, use originals within the following ranges:

Paper weight range: 16 to 24 lb/60 to 90 gsm

Paper size range: 5.5×8.5"/A5 (Short Edge feed only)
8.5×11"/A4 and 8.5×14"/216×353 mm

The ADF comes from the factory with the Auto Start feature disabled. Refer to **Customizing Your Pro 215** section of this User Guide for information about changing this setting.



1. Select the required paper tray.
2. Select the desired copy features from the control panel.
 - The maximum copy quantity is 100 for 1-sided output and 1 for 2-sided output. Reinsert the originals into the ADF for multiple copies of 2-sided output.
3. Adjust the paper guide to the original size.



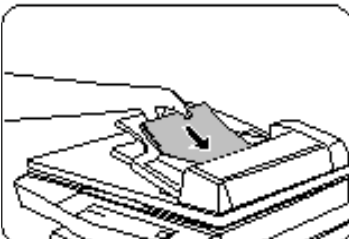
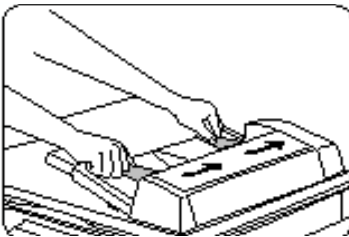

Note: Writing that is very close to the leading or trailing edge of the original may not copy. Turning the original around in the ADF may help.

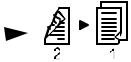

4. Insert up to 30 originals **face up** into the ADF until the green ADF light on the copier diagram comes on.

Making Copies on the Automatic Document Feeder

The available copy options are:

| Icon | Original | Copy | Max Quantity |
|---|--------------|--------------|--------------|
|  | Two-sided | Single sided | 100 sets |
|  | Two-sided | Two-sided | 1 set |
|  | Single sided | Two-sided | 1 set |
|  | Single sided | Single sided | 100 sets |

Single sided original to single sided copies (1→1)

This mode will create single sided copies from your originals.

1. Place the originals **face up** in the ADF.
2. Select the  icon and any additional features and the desired quantity.
3. Press Start to begin copying.

The Pro 215 will produce the requested number of **uncollated** (1,1,1...2,2,2...3,3,3...) single sided sets.

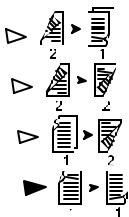

Making Copies on the Automatic Document Feeder

Single sided originals to two-sided copies (1→2)

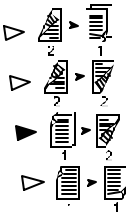

This mode will create two-sided copies from your single sided originals.

1. Place the originals **face up** in the ADF.
2. Select the  icon and any additional features.
 - The maximum copy quantity is 1. Reinsert the originals into the ADF for each set required.
3. Press Start to begin copying.

The Pro 215 will produce one set of two-sided copies.

Two-sided originals to two-sided copies (2→2)

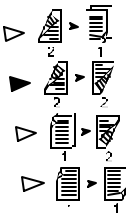

This mode will create two-sided copies from your two-sided originals.

1. Place the originals **face up** in the ADF.
2. Select the  icon and any additional features.
 - The maximum copy quantity is 1. Reinsert the originals into the ADF for each set required.
3. Press Start to begin copying.

The Pro 215 will produce one set of two-sided copies.

Two-sided originals to single sided copies (2→1)

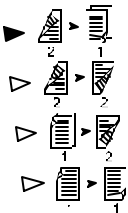

This mode will create single sided copies from your two-sided originals.

1. Place the originals **face up** in the ADF.
2. Select the  icon and any additional features and the desired quantity.
3. Press Start to begin copying.

The Pro 215 will produce the number of **uncollated** single sided sets that you requested.

Manual Two-Sided Copying

Important Tip: The Pro 215 has been configured to copy onto 8.5×11/A4 paper. When copying onto any other paper size the image may not be placed properly. The default paper size for both paper trays is 8.5×11/A4.

You may want to change the default setting for one or both of the trays if you find the factory settings do not meet your needs. Refer to **Customizing Your Pro 215** for information about changing the default paper size.

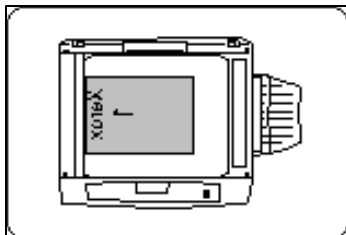

1. Place side 1 original **face down** on the Document Glass, with the **TOP** toward the **LEFT**. Lower the document cover.

Note: 16 lb / 60 gsm copy paper is not recommended for two-sided copying.

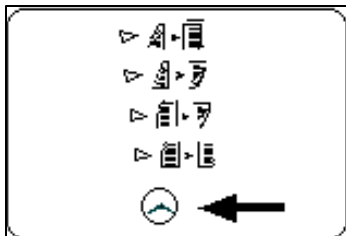

2. Select the desired 1-Sided/2-Sided mode.
3. Select the quantity.
4. Press Start to make side 1 copies.
 - After scanning side 1, the light next to the selected mode will flash to let you know that the Pro 215 is ready to scan side two.

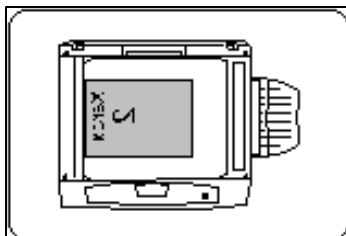

5. Remove the side 1 original and place the side 2 original **face down** on the Document Glass with the **TOP** toward the **LEFT**. Lower the document cover.
6. Press Start.

Image Quality

The image quality features described on this page can be used to improve copies of documents printed on colored paper, photographs, or are of poor quality.

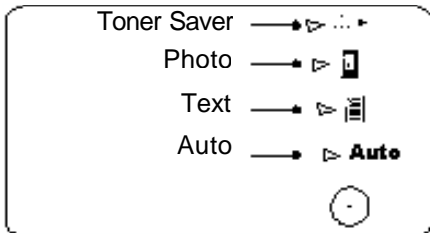

Auto: Use Auto when copying from originals with a colored background or mixed text and graphics.

Note: When Auto is selected, the copier automatically varies the contrast of your copies. Lighter/Darker settings are not available.

Text: Use Text to copy documents containing mostly text.

Photo: Use Photo when the originals are photographs.

Toner Save: Toner Save mode lowers overall copy density on each page. This feature can be used when making draft copies.

Copy Contrast

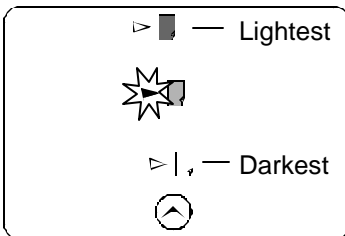

You can vary the copy contrast of your copies in small increments when Text, Photo, or Toner Save settings are selected.

Note: When Auto is selected the copy contrast settings are not available.

Press the copy contrast key to lighten or darken copies while in the Text, Photo, or Toner Save settings.

There are 5 contrast settings represented by 3 indicator lights. The indicators light up one or two at a time to represent the selected setting. Successive pushes of the key will change the indicators in successive order. Darkest, normal and lightest settings are depicted by one indicator. When 2 indicators are lit, the copy contrast will be mid point between the darker setting and the lighter setting.

Reduction/Enlargement

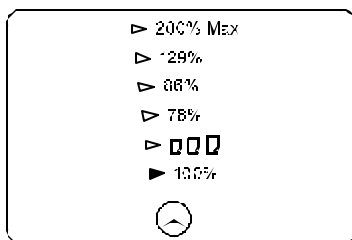

Preset Reduction/Enlargement

Press the Preset Reduction/Enlargement key to quickly select one of the 6 preset percentages. The customer settable percentage (□□□) has been set at the factory for 50%. Refer to **Customizing Your Pro 215** for information about changing the default percentage.



Variable Percentage

Press the Variable Percentage key to increase or decrease the reduction or enlargement by 1% increments. You may select any percentage from 50 – 200%. Press the % key to display the current percentage. When any reduction or enlargement is selected the variable percent indicator will light.



Display Window

Preset or variable reduction/enlargement percentages appear in the Display Window at the time selections are made. After a few seconds, the reduction/enlargement percent is replaced with the number of copies selected. Press the % key to recall the current reduction/enlargement ratio.

Reduction/Enlargement Reference Table

| Original Size | Copy Size | % To Use |
|---------------|-----------|----------|
| 5.5 × 8.5 | 8.5 × 14 | 154% |
| 5.5 × 8.5 | 8.5 × 11 | 129% |
| 8.5 × 14 | 8.5 × 11 | 78% |
| 8.5 × 11 | 5.5 × 8.5 | 64% |
| A4 | A3 | 141% |
| B4 | A4 | 81% |
| A4/ A3 | A5/ A4 | 71% |

Alternate Paper Tray

The alternate paper tray can be used to feed multiple sheets of standard paper, or it can be used to feed single sheets of special or heavy papers such as note cards, transparencies, and labels.

The alternate paper tray holds up to 50 sheets of 20 lb/ 80 gsm paper ranging in size from 3.5×5.5" to 8.5×14"/ A6 to 216×356mm.

Load special stock as follows:

Predrilled paper: holes toward the rear of the copier.

Letterhead paper: face down with the top toward the left.

Envelopes: flap side up and toward the rear, one at a time.

Labels: face down, one at a time.

Transparencies: removable stripe face up and toward the rear, one at a time.

- Use labels, transparencies, and envelopes specifically designed for copiers (high temperatures).

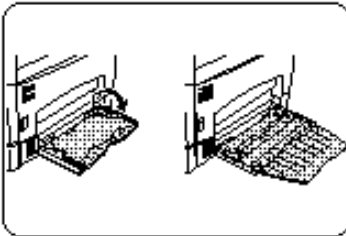

1. Place the original **face down** and align it with the registration guide on the document glass.
2. Lower the alternate paper tray, located on the right side of the copier.
3. Unfold the paper support extension as shown.

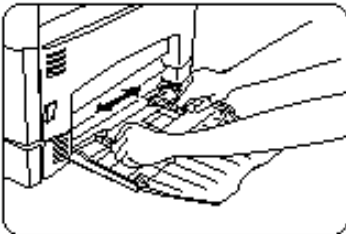

4. Adjust the guides to the width of the copy paper.

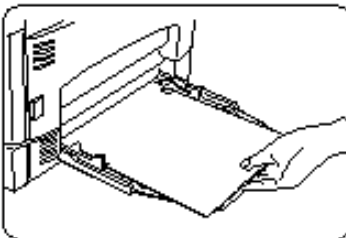

5. Insert the copy paper all the way into the alternate paper tray until it stops (do not force).
 - 50 sheets max.

Note: When loading envelopes, labels, or transparencies insert one at a time.

6. Press the Paper Supply button to select the alternate paper tray.
7. Select other required features.
8. Press the Start button.

Envelopes

Various types and sizes of envelopes can be printed/copied on the Pro 215 using the alternate paper tray.

Selecting Envelopes

The construction of envelopes is critical to printing performance and varies widely. Use high-quality envelopes that are thin and sharply creased. Test a few envelopes before you purchase large quantities.

Sizes: Minimum: 3 x 5" / 76 x 127mm
Maximum 8.5 x 14" / 216 x 356mm

Hints: Try to avoid printing over the area where the envelope's three back flaps meet.

Printing/Copying on an envelope: 

1. Load one envelope at a time into the paper tray bypass or alternate paper tray.
 - Make sure that the leading edge of the envelope is straight and firmly creased.
 - For the best print quality, position margins no closer than .5"/ 13mm from the edges of the envelope.
2. Slide the envelope into the bypass, flap side up and toward the rear.

Caution: The types of envelopes described below can severely damage your machine.

- Never use envelopes with clasps, snaps, windows, coated linings, exposed self-stick adhesives, or other synthetic materials.
- Never use envelopes with glues, inks, and adhesives that could discolor, scorch, or melt when heat is applied.
- Never try to print on both sides of an envelope. Jamming and damage can result.

Envelope Storage:

Proper storage of envelopes helps ensure successful feeding and printing.

- Envelopes should be protected from moisture. Excessive moisture can cause wrinkles and sealed flaps.
- Envelopes should be stored flat. Air can become entrapped during printing and cause creases to form. Flat storage helps prevent air entrapment.

Customizing Your Pro 215

Programmable Features

The default settings for various machine features may be changed to suit your individual needs. All of these features remain set until this process is repeated.

Each of the programmable features, along with its program number and options are contained in the chart below. The procedure to change the default settings follows the chart.

Note: The procedures written in this manual are based on the factory default settings.

| Feature | Program Number | Option Number * Factory Setting |
|--|----------------|--|
| Priority Tray: This feature allows you to set the default paper tray. At power on or auto clear, the copier will return to the selected priority paper tray. | 0 | 0 – Main paper tray * 1 – Alternate paper tray 2 – Second paper tray |
| Auto Clear Time Out: This feature allows you to select the time it takes for the copier to return to the normal copy mode after a copy cycle is complete. | 1 | 0 – Off 1 – 30 seconds 2 – 60 seconds * 3 – 90 seconds 4 – 120 seconds |
| Time Out to Power Save: When enabled, this feature automatically reduces power used by the copier if the copier has not been used for the set period of time. | 2 | 0 – Off 1 – 45 seconds 2 – 90 seconds * 3 – 2 minutes 4 – 5 minutes |
| Time Out to Power Shut-Off: When enabled, this feature significantly reduces power used by the copier if the copier has not been used for the set period of time. | 3 | 0 – 2 minutes 1 – 5 minutes * 2 – 15 minutes 3 – 30 minutes 4 – 60 minutes 5 – 120 minutes 6 – Off |
| Default Magnification: This feature allows you to make copies slightly larger or smaller than the original, or the same size. | 4 | 0 – 100% * 1 – 99% 2 – 101% |
| Default Image Quality: This feature allows you to select the default Image Quality mode. | 5 | 0 – Auto Exposure * 1 – Text 2 – Photo |

| Feature | Program Number | Option Number * Factory Setting |
|---|----------------|--|
| <p>Auto Contrast Adjustment: The copy contrast range may be adjusted when the copy image is consistently too light or too dark in the Auto Image Quality mode.</p> | 6 | 0 – Lightest 1 – Lighter 2 – Normal * 3 – Darker 4 – Darkest |
| <p>Paper Trail Edge Deletion: The trail edge deletion can be turned Off to accommodate originals that have print to the very bottom edge. When Off, another 4 mm will copy, however the image quality may deteriorate as it gets closer to the bottom edge.</p> <p>When this feature is On each time the paper tray is opened edge deletion is disabled for the first copy. Edge deletion is enabled for the following copies.</p> | 7 | 0 – On * 1 – Off |
| <p>Automatic Document Feeder Auto Start: When enabled, the ADF will begin to copy as soon as paper is placed in the ADF.</p> | 9 | 0 – On 1 – Off* |
| <p>Reduction/Enlargement Preset: This feature allows you to set a specific preset reduction or enlargement setting for the  key.</p> | 10 | 50 – 200% Default 50% * |
| <p>Auto Paper Tray Switching: When enabled, the copier will automatically switch to another paper tray when the selected tray runs out of paper.</p> | 11 | 0 – On 1 – Off * |
| <p>Automatic Document Feeder Contrast Adjustment: The copy exposure range may be adjusted when the copy image is consistently too light or too dark.</p> | 12 | 0 – lightest 1 – lighter 2 – Normal * 3 – darker 4 – darkest |
| <p>Return to Print Mode: This feature allows you to select the time it takes for the copier to return to the print mode after a copy job is complete.</p> | 14 | 0 – 60 seconds * 1 – 90 seconds 2 – 120 seconds 3 – 150 seconds 4 – 180 seconds 5 – Off - no time out |

| Feature | Program Number | Option Number * Factory Setting |
|---|----------------|--|
| Default 1-sided/2-sided Mode: This feature allows you to select the default copy mode. | 17 | 0 – 1 to 1 * 1 – 1 to 2 2 – 2 to 2 3 – 2 to 1 |
| Default copy paper size for 2-sided copying from the document glass: | | |
| Top paper tray default: This feature allows you to select the default copy paper size for the upper paper tray. | 18 | 0 – 8.5 × 14 1 – 8.5 × 13 2 – 8.5 × 12.4 3 – A4/ 210 × 297mm 4 – 8.5 × 11 * 5 – B5/ 182 × 257mm 6 – 5.5 × 8.5 7 – A5/ 148 × 210mm |
| Lower paper tray default: This feature allows you to select the default copy paper size for the lower paper tray. | 19 | 0 – 8.5 × 14 1 – 8.5 × 13 2 – 8.5 × 12.4 3 – A4/ 210 × 297mm 4 – 8.5 × 11 * 5 – B5/ 182 × 257mm 6 – 5.5 × 8.5 7 – A5/ 148 × 210mm |
| Printer configuration list: This feature allows you to print out printer configuration. | 20 | 0 – English 1 – French 2 – Spanish 3 – Italian 4 – German 5 – Portuguese |
| Printer font list: This feature allows you to print list of fonts embedded in printer. | 21 | 0 – English 1 – French 2 – Spanish 3 – Italian 4 – German 5 – Portuguese |

Programmable Feature Settings 0 – 9 and 11 – 21

To change the programmable features, find the Program Number and the desired Option Number in the Programmable features chart on the previous pages. Follow the instructions below.

Note: The Pro 215 must be off-line and in the Ready mode.

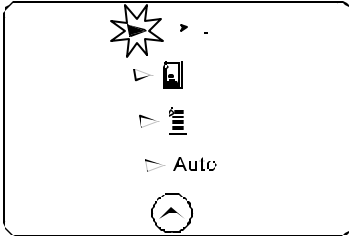

1. Select the Toner Saver mode.

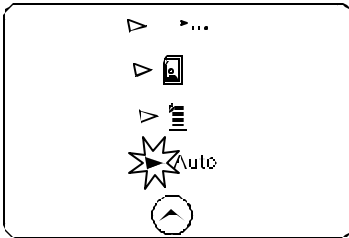

2. Press again and hold the Image Quality key for approximately 4 to 6 seconds.

- The light next to Auto mode will light.
- The lights within the Pro 215 Diagram will flash.

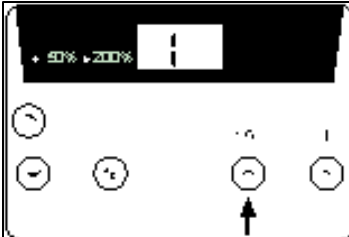

3. Press the 10 key to select the Program Number of the feature to be changed.

- You will not be given the choice to change an option if your machine does not have the feature.

4. Press Start.

- The current setting for that program will flash.



5. Press the 1 key until the option number you want is displayed.

6. Press Start to store the selection.

7. Press the Clear key to continue making other changes. Press the Image Quality key to return to the copy mode.

Programmable Feature Setting 10

Use the following procedure to change the preset Reduction/Enlargement default setting (□□□). This feature allows you to set a specific preset reduction or enlargement between 50 – 200%.

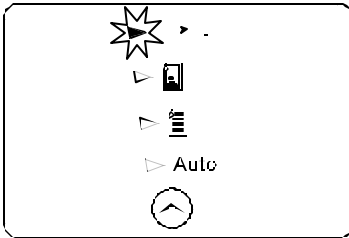

1. Select the Toner Saver mode.

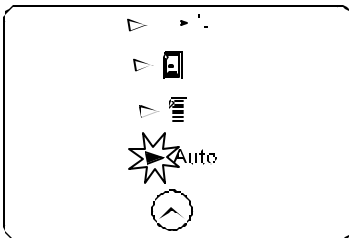

2. Press again and hold the Image Quality key for approximately 4 to 6 seconds.

- The light next to Auto mode will light.
- The lights within the Pro 215 Diagram will flash.

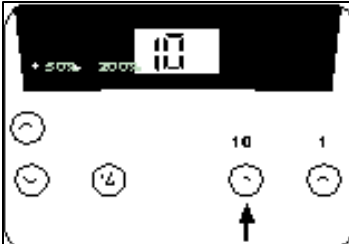

3. Press the 10 key until the number 10 is displayed.

4. Press Start.

- The current reduction/enlargement setting will flash.

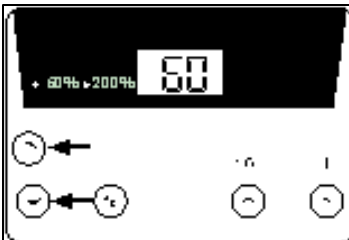

5. Press the variable percentage keys until the desired percentage is displayed.

6. Press Start to store the selection.

7. Press the Clear key to continue making other changes. Press the Image Quality key to return to the copy mode.

Pro 215 Care

Cleaning the Document Glass and Cover

Keeping the document glass clean helps ensure the best possible copies. Xerox suggests that you clean the document glass at the start of each day and during the day as needed.

CAUTION: Do not pour or spray water directly onto any part of the copier.

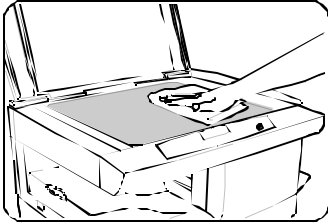

1. Slightly dampen a soft lint-free cloth or paper towel with water.
2. Wipe the surface of the document glass and the narrow glass adjacent to the document glass until it is clean and dry.
3. Wipe the underside of the white document cover until it is clean and dry.
4. Close the document cover.

Cleaning the Corotron Wire

If copies start getting streaks or blotches, the corotron wire may be dirty.

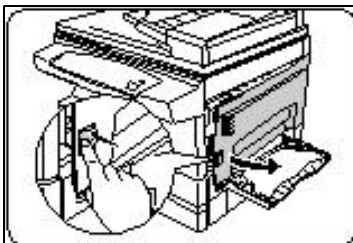

Note: Ensure that the alternate paper tray is lowered.

1. Press the release latch to open the side cover.

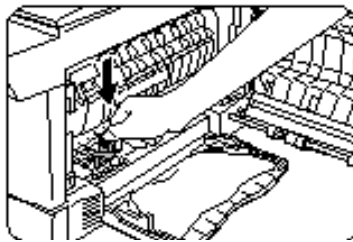

2. Remove the green corotron wire cleaner from inside the copier (near the front corner of the machine).

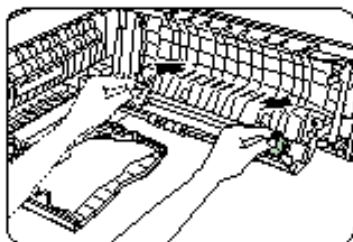

3. Insert the corotron cleaner into the corotron wire unit.
4. Wipe the corotron wire with the corotron cleaning tool as shown.
5. Replace the cleaner and close the side cover.

A1-A2 Automatic Document Feeder Misfeed

When a misfeed occurs in the feeder, the red ADF misfeed indicator flashes on the Copier Diagram, and an A1 or A2 status code will flash in the display window. The status code indicates the number of originals that must be returned to the feeder after clearing the misfeed.

A1 status code- refeed the last original.

A2 status code- refeed the last 2 originals.

This code will disappear when copying is resumed or the clear key is pressed.

Details for clearing the three types of feeder misfeeds are given below.

Input Misfeed

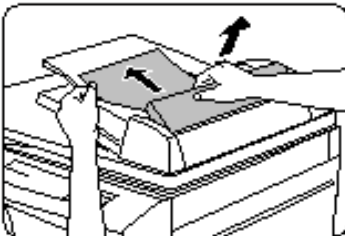

1. Open the feeding roller cover and pull the original gently to the left and out of the document feeder tray.
2. Close the feeding roller cover.
3. Open and close the document cover to clear the misfeed indicator.
4. Press Start to continue copying.

Exit Misfeed



1. Open the document cover and turn the roller knob to remove the misfed original from the exit area.

If paper cannot be easily removed, skip to the Roller Misfeed.

2. Close the document cover.
3. Press Start to continue copying.

Roller Misfeed

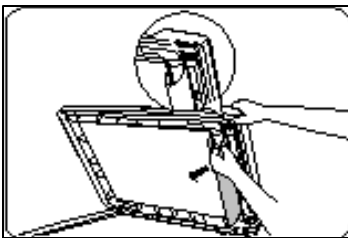

1. Open the document cover and turn the roller knob to remove the misfed original from the document feeder tray or the exit area. If the original is difficult to remove, gently remove it from under the feeding roller.
2. Close the document cover.
3. Press Start to continue copying.

– E2 Clearing the Paper Path

When a paper misfeed occurs the red misfeed indicator flashes on the copier diagram, and an E2 status code will flash in the display window. Paper misfeeds may occur in the areas shown below. Follow the steps below to locate and clear the misfeed.

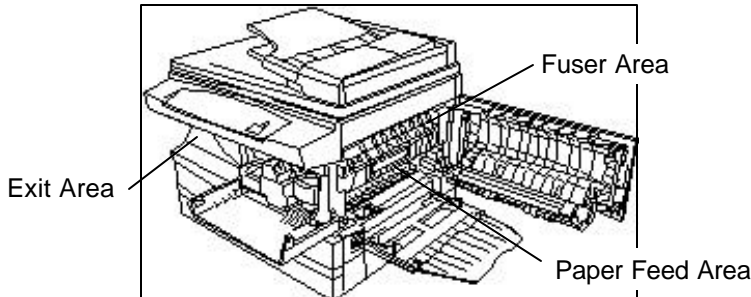

Paper Feed Area

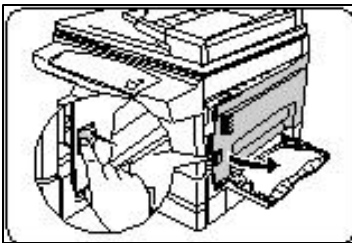

Note: Ensure that the alternate paper tray is lowered.

1. Press the release lever to open the side cover.

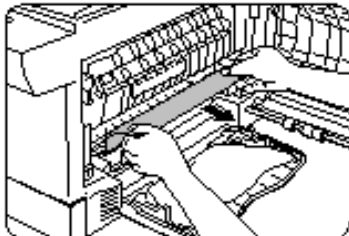

Caution: Do not touch the shiny drum cartridge surface. Scratches or smudges will result in poor copy quality.

Do not remove paper through the bypass. Unfused toner may adhere in the area, resulting in smudged copies.

2. Carefully remove the misfed paper in the direction shown.

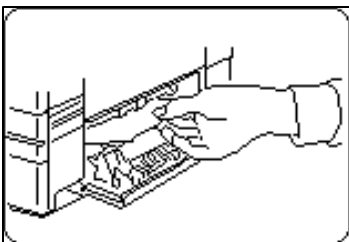

3. Lower the right side tray 2 access door.

4. Remove the misfed paper.

5. Close the access door.

If paper cannot be removed, skip to the Fuser Area.

6. Close the side cover.

– E2 Clearing the Paper Path (continued)

Fuser Area

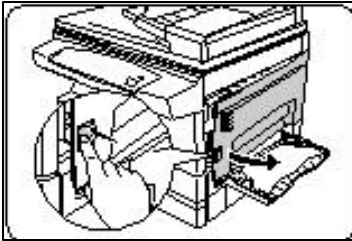

Warning: The fuser area is hot. Take care when removing paper from the fuser area.

Note: Ensure that the alternate paper tray is lowered.

1. Press the release lever to open the side cover.

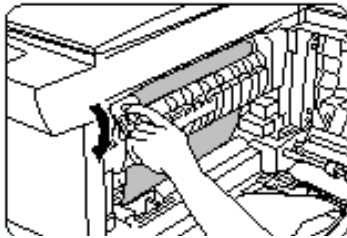

2. Pull down on the fuser lever.

- This will release pressure on the paper.

If paper is not seen in this area skip to the Exit Area.

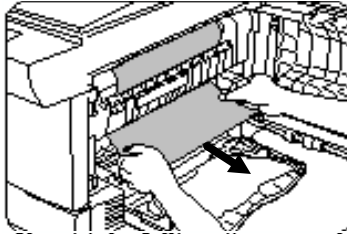

Caution: Do not pull paper up through the fusing unit. Unfused toner may adhere in the area, resulting in smudged copies.

3. Remove the sheet of paper, in the direction shown.



4. Push up on the fuser lever.

5. Close the side cover.

– E2 Clearing the Paper Path (continued)

Exit Area

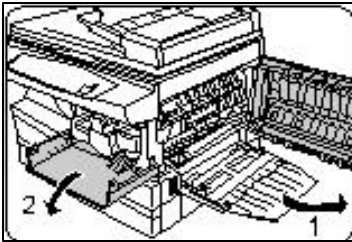

Note: Ensure that the alternate paper tray is lowered.

1. Press the release lever to open the side cover.
2. Press the front cover release buttons to open the front cover.

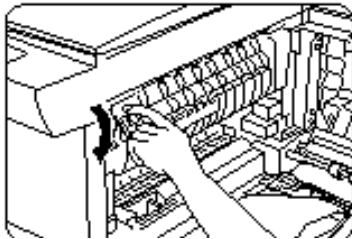

3. Pull down on the fuser lever.
 - This will release pressure on the paper.

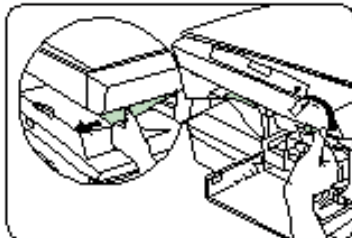

4. Turn the knob in the direction of the arrow to move the paper to the exit area.

5. Gently pull the paper out through the exit area.

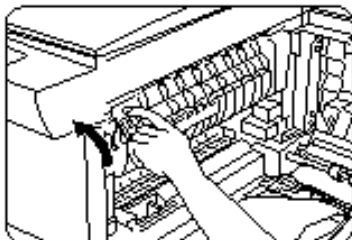

6. Push up on the fuser lever.
7. Close the front cover and side cover.

Toner Cartridge Replacement

The toner indicator on the copier diagram will light when the toner supply is low. Approximately 10 more copies can be made, but you should have a replacement cartridge in stock. When the J1 status code is displayed, the machine will stop operating until the toner cartridge is replaced.

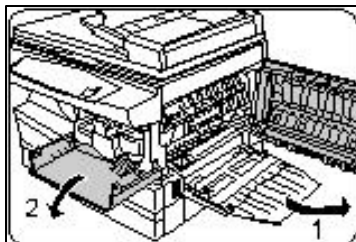

Note: Ensure that the alternate paper tray is lowered.

1. Press the release lever to open the side cover.
2. Press the front cover release buttons to open the front cover.

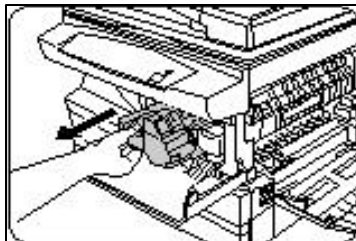

3. Press down on the green lever on the front of the old toner cartridge and pull the cartridge out.

Note: Help the environment by recycling your used toner cartridge. Refer to the recycling brochure packed with the Toner Cartridge for details.

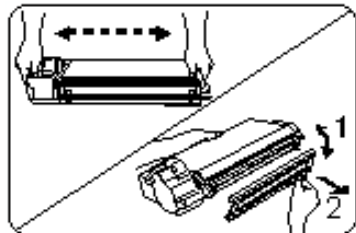

4. Shake the new toner cartridge horizontally four or five times and then remove the cover.
 - Save the box and the cover for shipping.

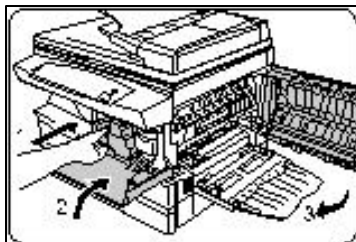

5. Slide the new toner cartridge in until it locks in place.
6. Close the front cover and the side cover.
 - Wait for the ready indicator to light.

Note: If a J3 is displayed, refer to page 51 for an explanation and clearance procedure.

Toner Cartridge Yield

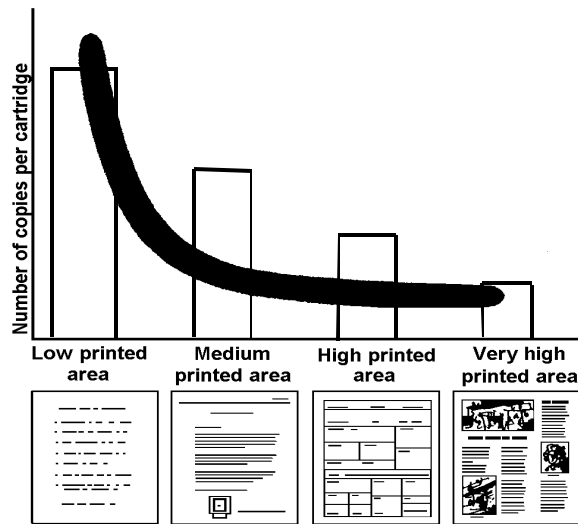

The main factor affecting toner cartridge yield is the printed area of a document. The graph is a sample representation of how the number of copies per cartridge decreases as the printed area increases.

- Other factors which can affect the toner cartridge yield are:
- The size of the document being copied.
- Dark backgrounds.
- Leaving the platen cover open.
- The number of times the copier is switched on and off.
- Double sided copying will use more toner per ream of paper.
- High humidity.

To get the most from your toner cartridge:

- Always copy with the document cover closed.
- Leave the copier on during the day. Switch off the copier at the end of the working day.
- Copy with the exposure control set to Auto exposure unless you need to adjust for the background of your original.
- Operate the copier in a dry environment whenever possible.

J2 Drum Cartridge Replacement

The useful life of the drum cartridge is approximately 18,000 copies. The drum cartridge indicator on the machine diagram lights when the drum is near the end of life. Approximately 1,000 more copies can be made, but you should have a replacement cartridge in stock. When the J2 Status Code is displayed, the machine will stop operating until the drum cartridge is replaced.

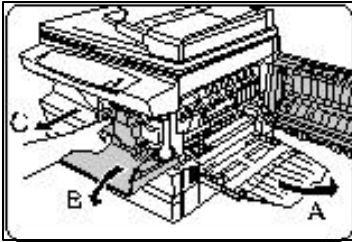

Note: Ensure that the alternate paper tray is lowered.

1. Press the release lever to open the side cover (A).
2. Press the front cover release buttons to open the front cover (B).
3. Press the green button (C) on the front of the toner cartridge and pull out the cartridge.

Note: The toner cartridge must be removed before removing the drum cartridge.

4. Pull out the drum cartridge.

Note: Help the environment by recycling your used drum cartridge. Refer to the recycling brochure packed with the drum cartridge for details.

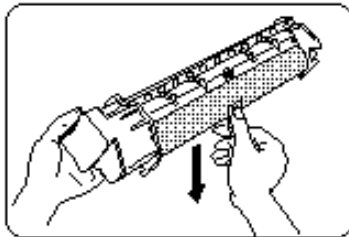
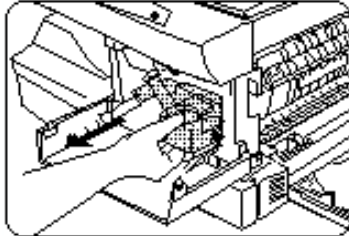

5. Remove the cover from the new drum cartridge.

CAUTION: Do not touch the shiny surface of the drum.

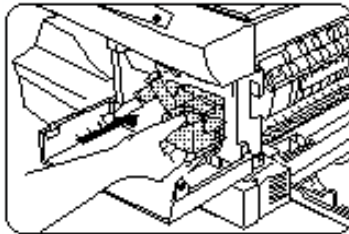

6. Slide the new drum cartridge in place, making sure not to touch the surface of the drum.
7. Reinstall the toner cartridge.
8. Close the front cover and the side cover.

Counter access

Total copies/prints remaining on the drum cartridge

This counter displays the total number of copies/prints remaining on the drum in the machine. The count can be used to determine when to reorder a new drum cartridge.

The count will be displayed in the display window as a sequence of 2-3 digit values.

Example 1: 10,145 copies/prints will be displayed as 010 followed by 145

Example 2: 361 copies/prints will be displayed as 000 followed by 361

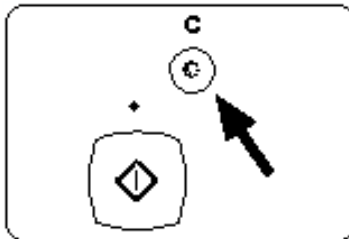
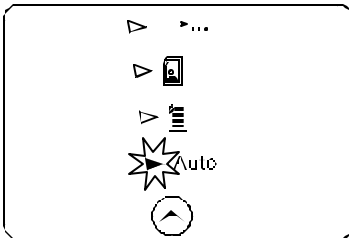

1. Select the Toner Saver mode.
2. Press again and hold the Image Quality key for approximately 4 to 6 seconds.
 - The light next to Auto mode will light.
 - The lights within the Pro 215 Diagram will flash.
3. Press and hold the Clear key for 5 seconds.
 - The count will continually be displayed until the Clear key is released. There will be a slight pause at the end, before displaying the count again.
4. Press the Image Quality key to return to the copy mode.

Printer Driver Software Installation

The printer driver software is the program that runs the printer. It converts the data in the file you want to print into information that the printer can understand. It also controls communication between the printer and computer as the data is printed.

You will need the following PC hardware and software in order to use the printer driver:

| | |
|---------------------------|--|
| Computer type | IBM PC/AT or Compatible Computer |
| Operating system | Windows 95/98 Windows NT 4.0 |
| CPU | 486DX 66 MHz or better |
| Connection | |
| IEEE-1284 parallel cable | To ensure reliability use the IEEE-1284 compliant parallel cable that is supplied with the machine. Only cables labeled "IEEE-1284" can be used with your Pro 215. |
| USB Cable* (not supplied) | To ensure reliability use a USB compliant cable purchased from your local vendor. |

* *Do not use the parallel and USB ports at the same time. The USB port is assigned the higher priority over the parallel port when more than one device is connected to the machine. When a system using USB is connected to the printer while no data is supplied to the 1284 port for more than one minute, priority will be assigned to the USB port for printer services.*

When the USB printing has been completed and disconnected, the 1284 port priority will resume in 60 seconds after disconnection.

Personal Computers without CD-ROM Drives:

There are several options available to you to obtain installation diskettes for the Pro 215.

1. If you have access to an alternate computer with a CD-ROM drive and a floppy disk drive, the WorkCentre Pro PCL Series CD-ROM has a program to create a set of installation diskettes. Refer to the **Creating Pro 215 Floppy Disk Installation Diskettes** section in this User Guide for instructions on making your own floppy diskettes.
2. Download the necessary software from the Xerox driver support Internet web site.

Installation Notes:

The Printer Driver Installation software cannot be installed using the **Add Printer Wizard**. Please use one of the following methods depending on your operating system.

IEEE 1284 Parallel Connection

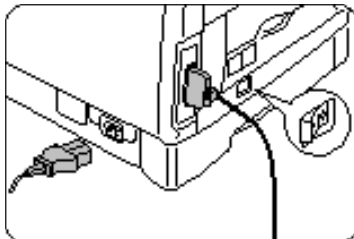

1. Ensure that the computer and the Pro 215 are turned off.
 2. Plug the IEEE-1284 cable into the parallel port on the Pro 215.
 3. Plug the other end of the IEEE-1284 cable into the computer.
4. Ensure that the power cord is plugged into the Pro 215 and then into a grounded outlet.
 - Do not attach your Pro 215 to a pass-through port of another device (scanner, CD-ROM drive, tape drive, Zip™ drive or external disk).
 5. Turn on the PC.
 6. Start Windows on your computer.
 7. Insert the WorkCentre Pro Series CD-ROM into the CD-ROM Drive.

Note: For Windows 95 and NT 4.0, go to step 8 of the Installation procedure on the next page for the software version that you are running. For Windows 98, go to the Plug-n-Play driver installation on the next page.

USB Connection

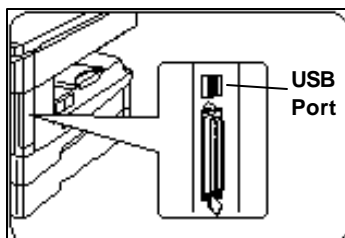

1. Turn off the computer and the Pro 215.
 2. Plug the USB cable into the Pro 215 USB port.
 3. Plug the other end of the USB cable into the PC USB port.
 4. Ensure that the power cord is plugged into the Pro 215 and then into a grounded outlet.
5. Turn on the Pro 215 and the PC, and wait for Windows to start.
 6. When the Add New Hardware Wizard screen appears, insert the WorkCentre Pro PCL Software CD-ROM into the CD-ROM drive.
 7. Follow the Wizard instructions to install the USB driver.

Installation for Windows 95 or NT 4.0 (continued from step 7)

8. Click on the **Start** button and then choose the **Run** menu option.
9. Type **D:\SETUP** (or the appropriate drive letter depending on your CD-ROM Drive) in the command line box. Click on the **OK** button to proceed.
10. Turn on the Pro 215.
11. Follow the on-screen instructions.
 - If you wish to print a test page, ensure paper is loaded and then click the **Yes** button.

Plug-n-Play (PnP) Printer Driver Installation

1. If your PC operating system is set to identify PnP devices, the new WorkCentre will be detected through the PC connection port. At the “Add New Hardware” dialog, click **Next** to proceed. The PnP installation will start SETUP.EXE from the Xerox software CD-Rom.
2. Follow the on-screen instructions for installing the print driver.
3. The WorkCentre Pro PnP printer driver will be installed on your PC.

Connecting the Pro 215 to a Network (optional)

Your WorkCentre Pro 215 can be connected to an Ethernet network using a dedicated external print server. In order to connect the WorkCentre Pro 215 to your network, you must first purchase a network print server. A Xerox Ethernet Adapter may be purchased from Xerox or alternative print servers may be purchased from your local retail store.

Connecting the print server

1. Install the WorkCentre Pro 215 driver software. For installing the Printer Driver see “**Printer Driver Software Installation**” or the instructions on the back of the Printer Driver CD. You may connect and test the WorkCentre Pro 215 as a directly connected device with the parallel cable supplied. When completed, disconnect the parallel cable from the WorkCentre Pro 215.
2. Ensure the WorkCentre Pro 215 power switch is in the OFF position.
3. Connect the network print server to the parallel port of the WorkCentre Pro 215.
4. Insert the Ethernet Cable into the other end of the print server.
5. Turn the WorkCentre Pro 215 ON.
6. Connect the Power Supply to the print server in order to turn it on.
7. Follow the instructions for connecting the print server to the network provided with the print server.

NOTE: For the PCs that will use the WorkCentre Pro 215 as the network printer, ensure that the network path to the print server device is selected in the “Ports” tab of the WorkCentre Pro PCL properties.

Memory Upgrade

The WorkCentre Pro 215 comes standard with 8 megabytes (MB) of random access memory (RAM). Industry standard Memory Modules are available allowing your machine to be upgraded to a maximum of 72 MB of RAM.

| Description | Recommendation |
|---------------------|--------------------------|
| Type | EDO-DIMM |
| Package | 168-pin |
| Dimensions | |
| Height | 1" |
| Width | 5.25" |
| Access Time | 60 nanoseconds |
| Voltage | 3.3V |
| Parity/ No Parity | Type |
| Buffered/Unbuffered | Unbuffered |
| Single/Dual Bank | Single Bank |
| Size | 8MB, 16MB, 32MB, or 64MB |

Pro 215 Properties (Printer Driver)

The purpose of this section is to provide information about how to access and use the options in the WorkCentre Pro PCL Series Printer Driver Properties dialog. Use the WorkCentre Pro PCL Properties dialog to change the settings used for printing for both PCL 5e and PCL 6 drivers.

There are several ways to display the Printer Driver dialog, including:

- **Displaying the Driver Properties dialog from an application**
- **Displaying the Properties dialog from the Start Menu**
- **Displaying the Properties dialog from the Xerox Printer Services Program (Status Monitor)**

Displaying the Driver Properties dialog from an application

Control of the driver settings is provided from the WorkCentre Pro PCL Series Properties (Printer Driver) dialog box. The new driver settings will be active while the application is open. The driver settings will return to the prior values when the application is exited.

Access to the Properties dialog will vary depending upon the application that is in use.

Note: The application may override any options that are selected using the Properties Dialog.

Windows 95/98 and NT:

1. Click **Print** on the application's **File** menu
2. If not selected, select the **Xerox WorkCentre Pro PCL Series** printer
3. Click the **Properties** button
4. Change the print options and click **OK**

Pro 215 Properties (Printer Driver)

Displaying the Properties dialog from the Start Menu

Windows 95/98 and NT

1. On the **Start Menu**, click **Settings**. On the Settings submenu, click **Printers**.
2. Right click on the **XEROX WorkCentre Pro PCL Series** printer icon and click **Properties**, or click **Properties** from the File menu.

Displaying the Properties dialog from the Xerox Printer Services Program (Status Monitor)

Windows 95/98 and NT

1. Click on the **Properties** button in the Xerox Printer Services window.

Pro 215 Properties (Printer Driver)

Properties Tabs

The WorkCentre Pro PCL Series Printer Driver Properties dialog contains four tabs from which you can make selections that best suit your printing requirements. Below is a brief description of each tab.

Note: Refer to On-line Help for detailed information.

Paper/Output — to select desired paper source (tray), number of copies, paper size, document orientation (portrait or landscape), number of images to print per page, print page borders, fit to page, and 2-sided printing.

Image Quality — to select the graphics mode, graphics quality, resolution, and text modes.

Device Options — to select page protection mode, designate the amount of memory installed in the printer and to control the use of printer resident fonts.

Watermarks (*PCL6 driver only*)— to add, delete or edit watermarks.

About — to display the driver version and copyright information.

On-Line Help

The WorkCentre Pro PCL Series Printer Driver includes a comprehensive on-line help system, designed to answer all your questions about using the Xerox WorkCentre Pro PCL Series Properties dialog.

The help system is your on-line user guide, providing complete introductory and reference information. It also provides troubleshooting information, in case you should run into any problems.

When you have a question simply click on the Help button on the Xerox WorkCentre Pro PCL Series Properties dialog.

The main Help Topics window will be displayed.

Printer Driver Help

To view an explanation of any field or button in the dialog window:

1. Click the  icon located in the upper right corner of the dialog window, and release the mouse button.
 - The cursor will change to a question mark.
2. Place the question mark on the field or button that you want defined, and release the mouse button.
 - The on-line Help file will display information on the selected subject.

PCL Printer Driver Features

| Setting | Usage/Description | PCL 6 | PCL 5e |
|------------------------|---|--------------|---------------|
| Number of copies | Select 1-99 copies | x | x |
| Page orientation | Select Portrait or Landscape | x | x |
| Duplex printing | Print on both sides of sheet | x | x |
| Paper size | Select from supported paper sizes (See Technical Data) | x | x |
| Custom size | Identify custom sizes | x | |
| Paper source | Select printing from multipurpose paper feeder or manual feeder | x | x |
| Resolution | Select 300 or 600 dpi print resolution | x | x |
| Graphic quality | Select enhancement for graphical and/or text printing | *1 | |
| Graphic mode | Select HP-GL/2, Vector or Raster mode. | x | x |
| TrueType fonts | Select font printing | x | x |
| Multiple images (N-Up) | Select 1-4 images per physical page | x | |
| Watermarks | Create and use watermarks on documents | x | |

¹This setting is not available in the Windows NT 4.0 version of the PCL 6 driver.

Creating Pro 215 Floppy Disk Installation Diskettes

If floppy diskettes are required to install the WorkCentre Printer Driver Software, the user can create a set of diskettes from CD-ROM.

To create a set of WorkCentre Pro Series Printer Driver floppy Diskettes, find a PC that has a floppy diskette drive with a CD-ROM drive and follow the procedure below. Four or five blank high density diskettes will be required.

For Windows:

1. Insert the **WorkCentre CD** into the CD-ROM Drive.
2. Click on the **Start** button and then choose the **Run** menu option.
3. Type **D:\MAKEDISKMAKEDISK.EXE** (or the appropriate drive letter depending on your CD-ROM Drive) in the command line box. Click on the **OK** button to proceed.
4. Follow the on-screen instructions.

To use the Floppy Disk Installation Disks created, follow the same procedure for your operating system but refer to the floppy disk drive (A:\ or B:\) rather than the CD-ROM drive (D:).

Enabling High Speed Printer Communications

Your Xerox WorkCentre Pro Series Digital Copier/Printer has been designed to provide excellent copy and print quality with high productivity. To ensure the highest print performance, the Xerox WorkCentre Pro Series Digital Copier/Printer was designed to take advantage of high speed parallel port communications between your personal computer and your Xerox WorkCentre Pro Series Digital Copier/Printer. This can be accomplished by enabling the **Extended Capabilities Port (ECP)** mode for your personal computer parallel port (LPT1, LPT2 etc.).

What is ECP?

ECP is a particular type of personal computer interface for printers that was established by the IEEE-1284 standard. Personal computers with this type of printer interface can enable printing up to four times faster than personal computers without ECP.

How do you know if ECP is enabled on your computer?

Many computers will give a status of the printer port settings through the Windows™ control panel and printer settings folders. Others may give the status by special software on the personal computer to view BIOS settings or CMOS settings. When you install the Xerox WorkCentre Pro Series Digital Copier/Printer driver software on your personal computer, the install software will automatically check your personal computer for you. If your personal computer is not running in ECP mode, the driver software will remind you that higher printing performance would be achieved if ECP were enabled.

How will your printing performance be affected if you do not have an ECP compatible personal computer, or if you do not enable ECP mode?

Since the rated print speed of the Xerox WorkCentre Pro Series Digital Copier/Printer has been verified with ECP mode, the only effect you may notice is a slight reduction in the print speed.

Are there any other requirements for ECP mode?

Always use an approved IEEE-1284 compliant cable (as the one supplied with your Xerox WorkCentre Pro Series Digital Copier/Printer). Never use pass-through devices (scanners, CD devices, tape drives, switch boxes, Zip drives, etc.) attached to the same port as the Pro 215. Each device should be on a separate parallel port (LPT1, LPT2 etc.) for the greatest reliability.

What can you do if your personal computer does not appear to have ECP mode enabled?

- 1) Check your personal computer documentation for a description of this feature. Particularly look for BIOS and/or CMOS settings, etc.
- 2) Call your personal computer's manufacturer. Be prepared with the model number and serial number.
- 3) Contact a computer sales or service near you, and inquire about an ECP board option for your personal computer that will allow your personal computer to operate in this mode.

Problem Solving

Problem Solving Chart





The following chart lists some conditions that may occur and the recommended solutions. Follow the suggested solutions until the problem is corrected. Refer to the Status Code Chart in this section for status code information. If the problem persists, please refer to the **Information** section for the appropriate telephone numbers.

| Condition | Suggested solutions |
|---|---|
| Ready indicator does not light. | Check that the Pro 215 is plugged into an electrical receptacle. Ensure that there is power to the receptacle and that the Pro 215 power is in the ON position. |
| Copies are too light or too dark. | If the original is light, select the lower copy contrast position to darken the background of the copies. If the original is dark, select the upper copy contrast position to lighten the background of the copies. |
| Smears, lines, marks, or spots on copies. | If defects are on the original, press the copy contrast key to lighten the background of your copies. If no defects are on the original, clean the document glass and underside of the document cover. (Refer to Pro 215 Care .) If the above solutions do not help, clean the corotron wire. (Refer to Pro 215 Care .) |
| Copy image is skewed. | Ensure that original is positioned correctly on document glass. Check that copy paper is loaded correctly. |
| Blank copies. | Ensure that the original is face down on the document glass or face up in the ADF. Check for a broken corotron wire. Refer to Pro 215 Care section for the location of the corotron wire. |

| Condition | Suggested solutions |
|---|--|
| Image rubs off the copy easily. | <p>Ensure the unit is plugged directly into the wall, not into a power strip.</p> <p>Ensure the fuser pins have been removed.</p> <p>Replace the paper in the tray with paper from a new package.</p> <p>In high humidity areas do not leave paper in the Pro 215 for extended periods of time.</p> |
| Frequent copy paper jams. | <p>Ensure the fuser pins have been removed.</p> <p>Fan the stack of paper, then turn it over in the tray.</p> <p>Replace paper in paper tray with a fresh supply.</p> <p>Check/adjust paper guides.</p> <p>Ensure that the paper is the proper paper weight. 20 lb / 80 gsm bond paper is recommended.</p> <p>Check for copy paper or pieces of copy paper remaining in the Pro 215 after a paper jam has been cleared. (Refer to Clearing the Paper Path.)</p> |
| The three trouble indicators are lit in the Pro 215 diagram. | <p>The machine is in the program mode. Press the Image Quality key to exit.</p> |
| Toner yield is lower than expected and the Toner Indicator is on. | <p>Toner may be lodged in the cartridge. Remove the toner cartridge. Shake the toner cartridge and tap along the top of the toner cartridge over a waste receptacle. Take care not to touch the exposed toner on the left side of the cartridge.</p> |
| Fewer copies from the Toner Cartridge than expected. | <p>Originals contain pictures, solids, or heavy lines.</p> <p>Originals are forms, newsletters, books etc.</p> <p>The Pro 215 is being turned on and off frequently.</p> <p>The document cover is being left open while copies are being made. (Refer to the Toner Cartridge Yield section.)</p> |

Problem Solving

Status Code Chart

| Status Code | Suggested Solution |
|---|--|
|  | Ensure that there is paper in the selected paper tray. Ensure that the Paper Tray is closed properly. Paper may not have fed all the way into the Pro 215. (Refer to Loading Paper and Flashing P.) |
| E2  | Copy paper has misfed. (Refer to Clearing the Paper Path.) |
| J1  | The toner indicator on the copier diagram will light when the toner supply is low. Approximately 10 more copies can be made, but you should have a replacement cartridge in stock. When the J1 status code is displayed, the machine will stop operating until the toner cartridge is replaced. |
| J2  | The drum cartridge indicator on the machine diagram lights when the drum is near the end of life. Approximately 1,000 more copies can be made, but you should have a replacement cartridge in stock. When the J2 status code is displayed, the machine will stop operating until the drum cartridge is replaced. |
| J3 | The toner cartridge is invalid. Install a valid Xerox Corporation toner cartridge. |
| C1 | The front or side cover is open. Close the cover. |
| CH | Install the toner cartridge. |
| A1 – A2 | Remove misfed paper from the ADF. Refer to A1 – A2 Automatic Document Feeder Misfeed for detailed instructions. |
| L1 | Ensure that the shipping screw is removed. |
| E7 F9 H2 – H4 L3 – L5 U2 – U5 | Switch OFF the Main Power. Wait approximately 5 seconds. Switch ON the Main Power. If the status code continues, call for service. |

Problem Solving

Printing Solution Chart

| Problem | Probable Cause | Remedy |
|----------------------------|--|---|
| The Pro 215 does not print | The IEEE-1284 Parallel cable or USB cable is not connected properly. | Check the cable connection. |
| | The IEEE-1284 parallel cable or USB cable is defective. | Check the cable with a computer and printer that work. If printing is still not possible, replace the cable. |
| | The port setting is incorrect. | Check the printer settings in the Windows Control Panel to make sure that the print job is being sent to the correct port. (For Example: LPT1.) |
| | The toner and drum cartridges are not installed properly. | Check that the toner and drum cartridges are installed properly. |
| | The printer driver may not be installed properly. | Uninstall and reinstall the Pro 215 printing software. |
| | The parallel port cable specifications may not be correct. | Use the IEEE-1284 parallel port cable supplied with the machine or replace it with an IEEE-1284 compliant cable. |
| Half of the page is blank | The page layout is too complex. | Reduce the resolution setting from 600 dpi to 300 dpi. |
| | The page orientation may be incorrect. | Change the page orientation in the printer setup dialog. |
| | There may be too many applications open. | Try closing other applications before printing. Reduce resolution from 600 dpi to 300 dpi. |
| | The computer CPU specification may be incorrect. | Check that the computer meets the minimum specification. |

| Problem | Probable Cause | Remedy |
|----------------------------------|--|--|
| Printing is too slow | The computer parallel port may not be set for high speed communications. | If your computer is equipped with an ECP parallel port, enable this mode of operation. Refer to the Enabling High Speed Printer Communications section and your computers user guide. |
| | If using Windows 95, the spool setting may be set incorrectly. | Point to the Start Task bar and then click Settings then Printers. Click the Xerox WorkCentre Pro 215 with the right mouse button. Click Properties and then spool settings on the details tab. Select the desired setting from the available choices. |
| | Print Job too large | Reduce resolution from 600 dpi to 300 dpi. (Refer to Pro 215 Properties (Printer Driver).) |
| Irregular faded patches of print | There is a paper quality problem. | Use only paper that meets the specifications required by the printer. |
| | Toner may be unevenly distributed. | Remove the toner cartridge and shake it gently to evenly distribute the toner. Then reinstall the toner cartridge. |
| Black staining | There is a paper quality problem. | Use only paper that meets the specifications required by the Pro 215. |
| Character voids | The paper may be too dry. | Try printing with a different batch of paper. |
| Background scatter | The paper may be too damp. | Try printing with a different batch of paper. Do not open packages of paper until necessary so that the paper does not absorb too much moisture from the air. |

| Problem | Probable Cause | Remedy |
|---------------------------|-----------------------------------|---|
| | Printing over uneven surfaces. | If printing onto envelopes, change your printing layout to avoid printing over areas that have overlapping seams on the reverse side. |
| Missing characters | The paper may be too damp. | Try printing with a different batch of paper. Do not open packages of paper until necessary so that the paper does not absorb too much moisture from the air. |
| Back of printout is dirty | The transfer roller may be dirty. | Print a few blank pages to clean the transfer roller. |
| Incorrect fonts | TrueType fonts may be disabled. | Use the Fonts dialog box in the Control Panel to enable TrueType fonts. |
| Faded graphics | Toner may be low. | Remove the toner cartridge and shake it gently to evenly distribute the toner. Then reinstall the toner cartridge. Ensure that you have a spare toner cartridge. |

Technical Data

| | | |
|--|--|-------------------|
| Original Size: Maximum 10×14" / B4 | | |
| Copy Ratio Percentages: 1:1 ± 1% | | |
| Preset: 50%*, 78%, 86%, 100%, 129%, 200% customer programmable | | |
| Zoom: 50% – 200% | | |
| Paper Size and Weight | | |
| Tray 1 and Tray 2 | | |
| 5.5×8.5 to 8.5×14" / A5 to 216×356mm | | |
| 15 - 24 lb / 56 - 90 gsm | | |
| Paper Tray Bypass | | |
| 3.5×5.5" to 8.5×14" / A6 to 216×356mm | | |
| 14 – 34 lb / 52 – 130 gsm | | |
| Copy Rate (8.5×11" / A4 and smaller) | | |
| 15 copies/minute | | |
| Print Rate (8.5×11" / A4 and smaller): 15 prints/minute | | |
| Paper Tray Capacity | Paper Tray | Paper Tray Bypass |
| | 2 × 250 | 50 |
| First copy output time: 9 seconds (warm) 23 seconds (cold) | | |
| Electrical Requirements: AC 120V ± 10%, 50/60 Hz, 9.5A | | |
| Machine Dimensions | Width × Depth × Height | |
| | 20.4 × 19.3 × 18.3" / 51.8 × 49.1 × 46.4cm | |
| Machine Weight (Includes Drum and Toner Cartridge) | | |
| 60 lbs / 27kg | | |
| Power Consumption: Max: 1.0kW | | |
| Shut off mode: 20 Watts | | |